

SATATYA DEVICES
System Manual

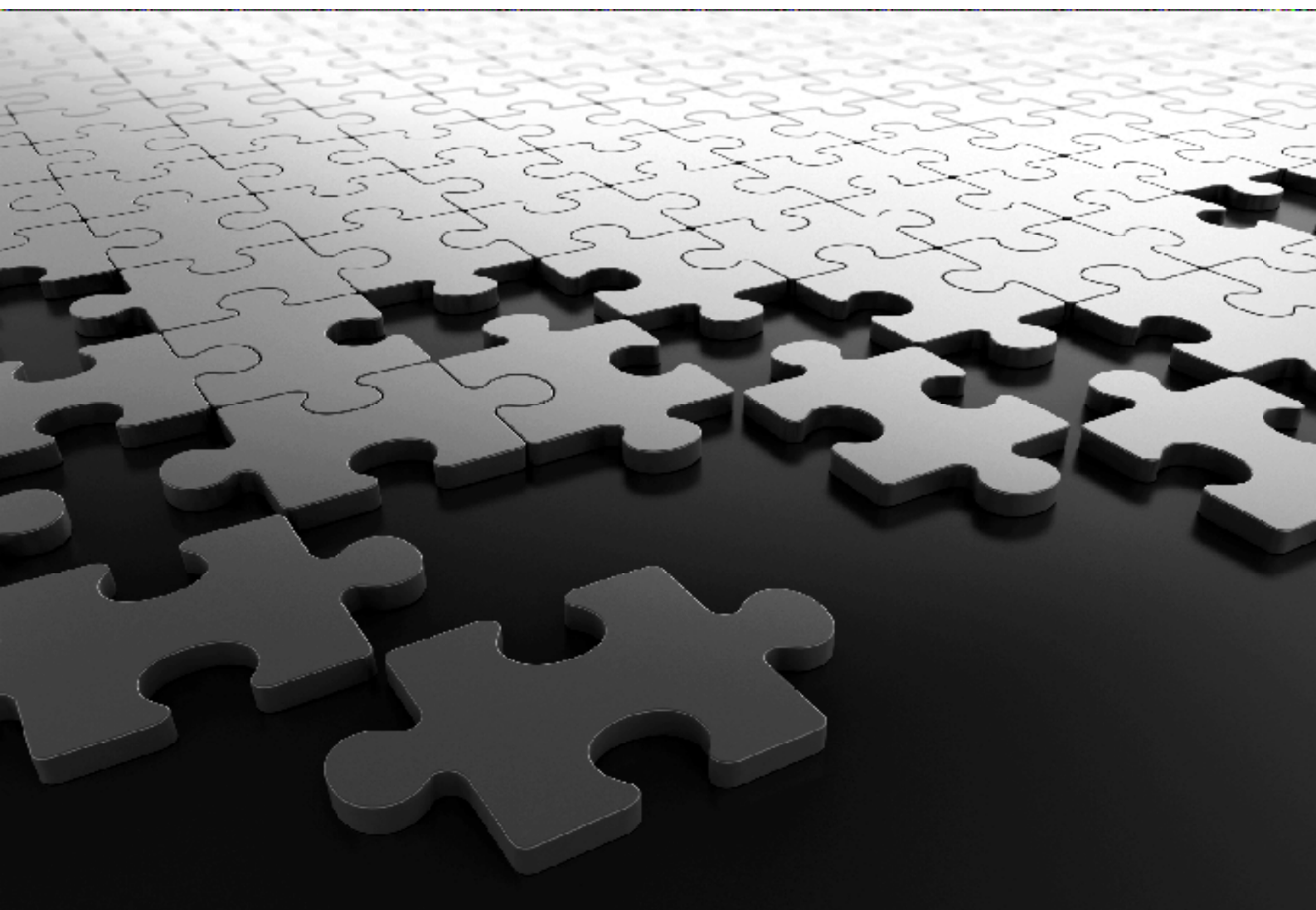

Matrix SATATYA Devices
Video Surveillance Solution with NVR and HVR

System Manual



Documentation Disclaimer

Matrix Comsec reserves the right to make changes in the design or components of the product as engineering and manufacturing may warrant. Specifications are subject to change without notice.

This is a general documentation for all variants of the product. The product may not support all the features and facilities described in the documentation.

Information in this documentation may change from time to time. Matrix Comsec reserves the right to revise information in this publication for any reason without prior notice. Matrix Comsec makes no warranties with respect to this documentation and disclaims any implied warranties. While every precaution has been taken in the preparation of this system manual, Matrix Comsec assumes no responsibility for errors or omissions. Neither is any liability assumed for damages resulting from the use of the information contained herein.

Neither Matrix Comsec nor its affiliates shall be liable to the buyer of this product or third parties for damages, losses, costs or expenses incurred by the buyer or third parties as a result of: accident, misuse or abuse of this product or unauthorized modifications, repairs or alterations to this product or failure to strictly comply with Matrix Comsec operating and maintenance instructions.

Copyright

All rights reserved. No part of this system manual may be copied or reproduced in any form or by any means without the prior written consent of Matrix Comsec.

Warranty

For product registration and warranty related details visit us at www.matrixcomsec.com

Safety Instructions

The product contains coin cell battery which is to be kept away from children. If swallowed, can cause severe internal burns.

Version 8

Release date: July 9, 2024

Contents

Introduction	1
Know Your SATATYA Device	5
<i>SATATYA Device Overview</i>	9
<i>System Architecture</i>	11
<i>SATATYA Network Video Recorder (NVR)</i>	11
<i>SATATYA Hybrid Video Recorder (HVR)</i>	25
Pre-Installation Information	37
<i>Typical SATATYA Device Installation layout</i>	42
Installing the SATATYA Device	43
<i>Selecting an Installation Location</i>	44
<i>Connecting the Device</i>	45
<i>USB Keyboard</i>	47
<i>Virtual Keypad</i>	50
<i>Using the IR Remote Control</i>	51
<i>Powering the SATATYA device</i>	53
<i>Cabinet Mounting</i>	55
<i>Installing Hard Disks</i>	70
<i>Hooking up Inputs</i>	90
Setting Network Parameters	91
Quick Setup Wizard	105
<i>Quick Setup</i>	106
Local configuration of the SATATYA Device	121
<i>About</i>	122
<i>Live View</i>	123
<i>View Cameras</i>	130
<i>Display Mode</i>	132
<i>Playback Search</i>	134
<i>Event Search</i>	135
<i>Settings</i>	137
<i>Manage</i>	138
<i>Device Status</i>	144
<i>Login/Logout</i>	145
<i>Volume Control</i>	146

<i>Quick Backup</i>	147
<i>Quick Setup</i>	148
<i>Live Events</i>	149
Recording and Playback	151
<i>Recording</i>	151
<i>Search and Playback</i>	153
Device Client	175
<i>About</i>	177
<i>Monitoring the Camera from left pane</i>	179
<i>Camera Monitoring Window</i>	217
<i>Device Configuration</i>	223
Basic Settings	225
Camera Settings	243
Network Settings	293
Storage and Backup Settings	315
Device I/O Settings	329
Event and Action Settings	333
<i>Icons on Monitoring Window</i>	341
Devices	343
User Account Management	347
Monitoring and Control Options	353
Maintenance	355
<i>Firmware Management</i>	355
Appendix	357
<i>Glossary of Terms</i>	357
<i>RAID Concept</i>	359
<i>Technical Specification</i>	364
<i>Disposal of Products/Components after End-Of-Life</i>	371
<i>Open Source Licensing Terms and Conditions</i>	372

Welcome

Thank you for choosing the Matrix SATATYA NVR/HVR for the Video Surveillance Solution. There has been a growing need for centralized management of security systems and controls using remote surveillance systems. The feature rich **Matrix SATATYA NVR** (Network Video Recorder) and **Matrix SATATYA HVR** (Hybrid Video Recorder) aims to cater to this requirement.

Users can use the on board web server to administer the NVR/HVR and access the video/audio streams. We are sure you will be able to make optimum use of this feature rich remote surveillance management system. Please read this document carefully to get acquainted with the product before installing and operating it.

About this System Manual

This is a common document providing detailed information and instructions for installing, configuring, managing and using the Matrix SATATYA devices as well as a general overview of the product functionality.

This manual consist of different variants of SATATYA NVR/NVRX/NVRX P2 and SATATYA HVR.

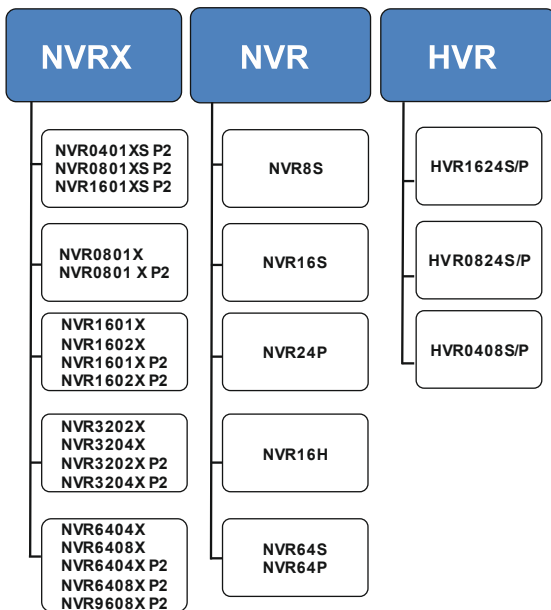

The SATATYA devices can be configured in the following ways:

- **Local Client:** One way is by accessing Setting menu via local client.

Local Client can be accessed using a display monitor which can be interfaced directly with the device.

- **Device-Client:** An another way is by accessing Configuration Settings menu via Device Client desktop application.

The SATATYA devices includes all of the necessary components for recording and viewing recorded sequences over the network and also to grab event related images.

Intended Audience

This System Manual is aimed at:

- **System Engineers**, who will install, maintain and support the SATATYA device. System Engineers are persons who are responsible for configuring the SATATYA system to meet the requirements of the organization/users. It is assumed that they are experienced in the installation of a SATATYA device and its components and are familiar with the cabling of such systems. They are expected to be aware of how it works, and the various technical terms and functions associated with it. The SE must have undergone training in the installation and configuration of the SATATYA system. No one, other than the System Engineers are permitted to make any alterations to the configuration of the SATATYA system.
- **System Administrators**, who are persons who will monitor, manage and use the SATATYA system after installation. Generally, an employee of the IT department in an organization or establishment is selected as the System Administrator. The System Administrators are not expected to setup and install the system hardware, but only the configuration of the system including its functionalities and features.
- **Users**, persons/organizations who will use the SATATYA system. They may be executives, include personnel of small and medium businesses, large enterprises, front desk and service staff of Hotels/ Motels, hospitals, and other commercial and public organizations/institutions.

Organization of this Document

This system manual covers the following topics:

- **Introduction** - gives an overview of this document, its purpose, intended audience, organization, terms and conventions used to present information and instructions.
- **Know Your Matrix SATATYA Device** - describes the system and its design including its various components as well as its features and functionalities.
- **Installing Matrix SATATYA Device** - gives step-by-step instructions for preparing and installing the Matrix HVRs and NVRs, its layout details, selection of installation location, the safety measures for protecting the system and persons handling the installation and maintenance, connecting the various devices like cameras, Hard Disks etc.
- **Configuring Matrix SATATYA Device** - provides instructions for accessing the various setting options on the Matrix device and configuring the same. This section also provides a step by step instruction for launching the inbuilt web server on the Matrix SATATYA device as also the instructions for accessing various configuring options directly from the device using the attached display.
- **Appendix** - Contains additional information related to the document. These include Technical Specifications of the Product, Glossary of terms, and the Product Warranty Statement, and others.

How to Read this System Manual

This document is organized in a manner to help you get familiar with the SATATYA device, learn how to install it, connect it in various network topologies, connect the external devices, and power up the hardware systems.

This System Manual is presented in a manner that will help you find the information you need easily and quickly.

You may use the table of contents and the Index to navigate through this document to the relevant topic or information you want to look up.

- **Instructions**

The instructions in this document are written in a step-by-step format, as follows. Each step, its outcome and indication/notification, wherever applicable, have been described.

- **Notices**

The following symbols have been used for notices to draw your attention to important items.



Important: to indicate something that requires your special attention or to remind you of something you might need to do when you are using the system.



Caution: to indicate an action or condition that is likely to result in malfunction or damage to the system or your property.



Warning: to indicate a hazard or an action that will cause damage to the system and or cause bodily harm to the user.



Tip: to indicate a helpful hint giving you an alternative way to operate the system or carry out a procedure, or use a feature more efficiently.



Hot Surface Warning: to indicate that the surface of the device enclosure is hot and you should be careful when you come in contact with the same.

Terminology used in this System Manual

The technical terms and Acronyms used in this Manual are standard terms, commonly used in the remote surveillance management industry. However, considering the broad group of intended users of this manual, wherever possible, use of jargon has been avoided.

The terms **Matrix SATATYA NVR**, **SATATYA NVR** and **NVR**, **NVRX** and are used interchangeably and refer to the **Matrix SATATYA Network Video Recorder**. The word NVR is used through-out the document and it represent NVR/NVRX/NVRX P2, unless specified. NVRX and NVRX P2 supports same features unless mentioned explicitly.

The terms **Matrix SATATYA HVR**, **SATATYA HVR** and **HVR** are used interchangeably and refer to the **Matrix SATATYA Hybrid Video Recorder**.

Using this Manual in conjunction with the **Matrix SATATYA Device Quick start**, we hope, you will be able to set up, configure and make optimum use of this feature rich product.

The documents are available on the website. To avail the documents, scan the QR Code on the product.

Technical Support

If you cannot find the answer to your question in this manual or in the Quick Start guide, we recommend you contact your system installer. Your installer is familiar with your system configuration and should be able to answer any of your questions.

For additional information or technical assistance with the Matrix SATATYA System or other Matrix products, contact our Technical Support Help desk, Monday to Saturday 9:00 AM to 6:00 PM (GMT +5:30) except company holidays.

Phone	+91 1800-258-7747
Internet	www.MatrixComSec.com
E-mail	Tech.Support@MatrixComSec.com

The purpose of this manual is to provide the user with all recommended procedures and full technical details for the successful installation, management, control and use of the SATATYA Video Recorders. This manual must be read, and its contents clearly understood, before proceeding with any work relating to the system. This manual is common for all the variants of SATATYA Video Recorders. The following variants are available:

Network Video Recorder

NVRX P2 Series Variants

The NVRX P2 series consists of — NVRXS P2 as well as NVRX P2. Details are as follows:

NVR0401XS P2: This NVR is having configuration of maximum 4 IP channels and 1 hard disk.

NVR0801XS P2: This NVR is having configuration of maximum 8 IP channels and 1 hard disk.

NVR1601XS P2: This NVR is having configuration of maximum 16 IP channels and 1 hard disk.

Naming Convention of NVRXS P2 series

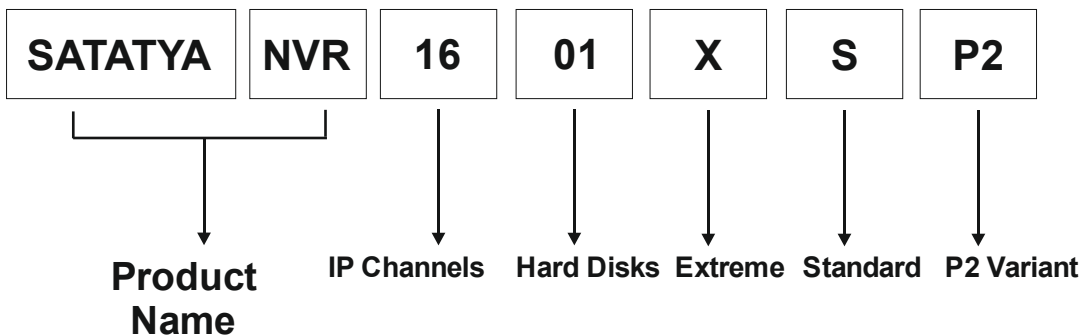

NVR0801X P2: This NVR is having configuration of maximum 8 IP channels and 1 hard disk.

NVR1601X P2: This NVR is having configuration of maximum 16 IP channels and 1 hard disk.

NVR1602X P2: This NVR is having configuration of maximum 16 IP channels and 2 hard disk.

NVR3202X P2: This NVRX is having configuration of maximum 32 IP channels and 2 hard disk.

NVR3204X P2: This NVRX is having configuration of maximum 32 IP channels and 4 hard disk.

NVR6404X P2: This NVRX is having configuration of maximum 64 IP channels and 4 hard disk.

NVR6408X P2: This NVRX is having configuration of maximum 64 IP channels and 8 hard disk.

NVR9608X P2: This NVRX is having configuration of maximum 96 IP channels and 8 hard disk.

Naming Convention of NVRX P2

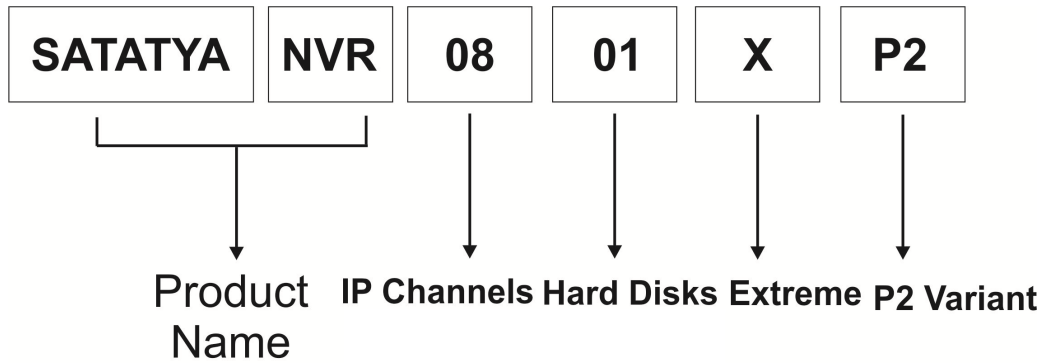

NVRX Series Variants

NVR0801X: This NVR is having configuration of maximum 8 IP channels and 1 hard disk.

NVR1601X: This NVR is having configuration of maximum 16 IP channels and 1 hard disk.

NVR1602X: This NVR is having configuration of maximum 16 IP channels and 2 hard disk.

NVR3202X: This NVR is having configuration of maximum 32 IP channels and 2 hard disk.

NVR3204X: This NVR is having configuration of maximum 32 IP channels and 4 hard disk.

NVR6404X: This NVR is having configuration of maximum 64 IP channels and 4 hard disk.

NVR6408X: This NVR is having configuration of maximum 64 IP channels and 8 hard disk.

Naming Convention of NVRX

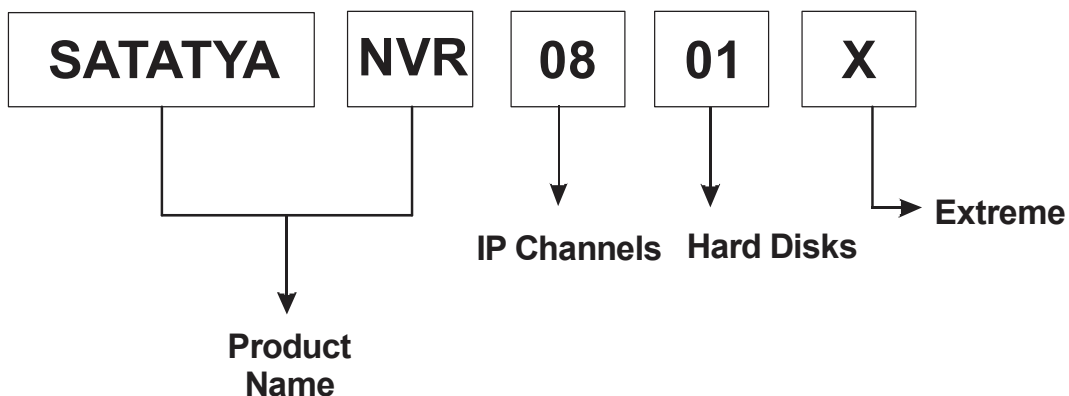

Other NVR Variants

NVR8S: This is Standard NVR having configuration of maximum 8 IP channels.

NVR16S: This is Standard NVR having configuration of maximum 16 IP channels.

NVR24P: This is Premium NVR having configuration of maximum 24 IP channels.

NVR16H: This is High-end NVR having configuration of maximum 16 IP channels.

NVR64P/NVR64S: This is Premium/Standard NVR having configuration of maximum 64 IP channels.

Naming Convention of NVR

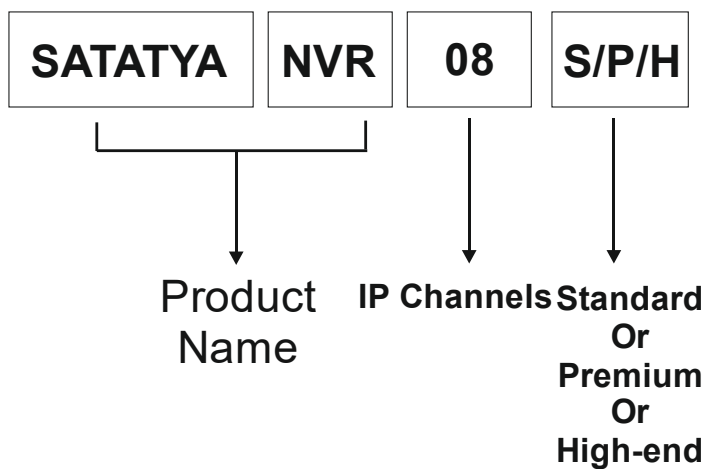

Hybrid Video Recorder

HVR Variants

HVR 1624P/ HVR 1624S: It refers to HVR **Premium** and HVR **Standard** respectively. This device supports maximum 24 channels. You can either connect all 24 IP cameras to the channel or with the combination of IP and Analog cameras, in which maximum 16 analog cameras can be connected.

HVR 0824P/ HVR 0824S: It refers to HVR **Premium** and HVR **Standard** respectively. This device supports maximum 24 channels. You can either connect all 24 IP cameras to the channel or with the combination of IP and Analog cameras, in which maximum 8 analog cameras can be connected.

HVR 0408P/ HVR 0408S: It refers to HVR **Premium** and HVR **Standard** respectively. This device supports maximum 8 channels. You can either connect all 8 IP cameras to the channel or with the combination of IP and Analog cameras, in which maximum 4 analog cameras can be connected.

SATATYA Device Overview

The SATATYA device is designed to meet the highest standards of remote surveillance applications. Used primarily via a direct Ethernet or Fast Ethernet network connection, the installation process is simple and the product integrates seamlessly into your networking and application environments. The Matrix SATATYA device offers a cost-effective imaging solution with minimal installation and maintenance costs.

This Hybrid Video Recorder (HVR) consists of maximum 4 Hard Disk storage and playback capabilities for maximum 24 channels of Hybrid Video Recorder.

Network Video Recorder Extreme (**NVRX series**) devices consists of maximum 8 Hard Disks storage while other NVR devices consists of maximum 4 Hard Disk storage with playback capabilities for maximum 64 channels.

Network Video Recorder Extreme (**NVRX P2 series**) devices consists of maximum 8 Hard Disks storage with playback capabilities for maximum 96 channels.

Network Video Recorder Extreme Standard (**NVRXS P2 series**) devices consists of maximum 1 Hard Disks storage with playback capabilities for maximum 16 channels.

The SATATYA **NVR** records directly from up to **64 IP** video cameras via standard network cabling.

The SATATYA **HVR** records directly from the combination of **24 Analog and IP** video cameras via standard network cabling.

All administration and viewing of recorded material can be done via Device Client desktop application. It supports major-brand IP cameras and integrates into a TCP/IP networking environment.

The SATATYA Device is designed to support following major features.

- **Ease of Use:** The SATATYA NVR/HVR is completely independent of any other server and is easily installed and configured. The system does not require any further hardware such as PC frame-grabber cards (conventional system to connect PC with Camera).
- **High quality H.265, H.264, MPEG-4 and M-JPEG recording.**
- **High reliability RAID 0, RAID 1, RAID 5 and RAID 10 support in NVR, HVR, NVRX and NVRX P2.** For more details about RAID levels and RAID configuration in NVRX [See "RAID Concept" on page 359.](#)
- **Supports most of the industries leading network camera manufacturers.**
- **Highly reliable maintenance-free Digital Security System:** The SATATYA device enables the user to have continuous unattended recording to a hard disk. Live images can be viewed while recording, administration can be performed at any time, and playback can be started while other recordings are in progress. Digital image storage eliminates the multiple-use degradation associated with video tapes.
- **Fully Configurable Event Settings:** The SATATYA device enables users to configure event settings based on which it is possible to configure pre-buffers and a fixed recording duration, as well as send event notification via e-mail.
- **Open Standards Environment:** The SATATYA device supports TCP/IP networking, SMTP, HTTP and other Internet-related protocols.

- **Remote access from any PC over the network for remote system operation and configuration.**
- **Event/alarm, manual and scheduled recording modes.**
- **Records and displays events directly - no waiting for tapes to engage or rewind.**
- **Event driven recording maximizes disk space by only recording when an event is detected.**
- **Instant video retrieval from recordings list.**
- **Automatic removal of recordings prior to X days/hours can be enabled.**
- **Simultaneous Video Search, Backup, Asynchronous and Synchronous Playback.**
- **Camera dependent recording resolution.**
- **Different variants to cater to the segment-wise requirements.**
- **Built-in support for PTZ Devices from the web user interface.**
- **Camera Initiation feature:** This feature allows configuring the camera to the devices.

To initiate the communication request towards the SATATYA Devices. In this scenario to get the camera added in SATATYA Device either manually or automatically.



To access this functionality, you need to prior add the server details of SATATYA device on the Camera web page.

This feature can be activated from the Basic setting > General setting page. For more details, refer ["Auto Add Camera"](#).

System Architecture

Please read the following information to familiarize yourself with the SATATYA devices, making particular note of where the connectors on HVR and NVR Panels are located. However, the number of connectors would vary as per the product variant. This section provides a useful reference when installing the product.

Refer the following links for NVR and HVR installation respectively.

- [“SATATYA Network Video Recorder \(NVR\)”](#)
- [“SATATYA Hybrid Video Recorder \(HVR\)”](#)

SATATYA Network Video Recorder (NVR)

The NVR includes the following — NVR series, NVRX series, NVRX P2 series The NVRX P2 series includes the NVRXS P2 series.

SATATYA Network Video Recorder of **Extreme Standard P2** series, abbreviated as **NVRXS P2** consists of the variants **NVR0401XS P2, NVR0801XS P2, NVR1601XS P2**. Click on the following link to know about the connectors of each variant.

[“NVRXS P2 Panels”](#)

SATATYA Network Video Recorder of **Extreme** series and **Extreme P2** series, abbreviated as **NVRX** and **NVRX P2** respectively, consists of the variants **NVR0801X/NVR1601X, NVR1602X/NVR3202X, NVR3204X/NVR6404X, NVR6408X, NVR0801X P2/NVR1601X P2, NVR1602X P2/NVR3202X P2, NVR3204X P2/NVR6404X P2, NVR6408X P2/NVR9608X P2**. Click on the following link to know about the connectors of each variant.

[“NVRX Panels”](#)

SATATYA Network Video Recorder, abbreviated as **NVR**, includes variants such as **NVR8S, NVR16S, NVR24P, NVR16H, NVR64P/NVR64S**. Click on the following links to know about the Front and Rear Panel connectors of each variant.

[“NVR Front Panels”](#)

[“NVR Rear Panel”](#)

NVRXS P2 Panels

NVR0401XS P2/NVR0801XS P2/NVR1601XS P2

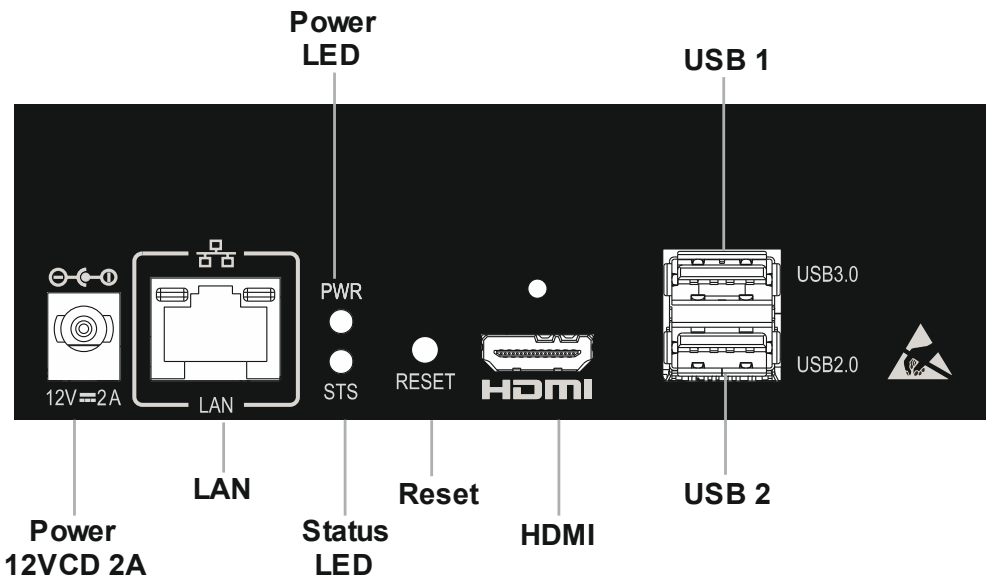

Ports and Connectors of NVRXS P2 Series

Interface	Description	All Variants
USB 3.0 (Upper)	USB 3.0, used for Manual Backup. To connect USB Mouse. To connect Dongle.	Yes Ratings: 5VDC - 500mA
USB 2.0 (Lower)	USB 2.0, used for Scheduled Backup. To used to connect USB Mouse. To connect Dongle.	Yes Ratings: 5VDC - 500mA
HDMI 2.0	To connect a high definition digital monitor or TV for Main view.	Yes
LAN (RJ45)	To connect a standalone personal computer, or a LAN Switch, or to connect to the Internet over a DSL Modem or Router. Ethernet Speed:10/100/1000Mbps	Yes
Reset	Press and hold down the reset button for atleast 4 seconds to default the following parameters. <ul style="list-style-type: none"> • LAN Settings • User Settings • General Settings 	Yes

NVRX Panels

NVR0801X/NVR1601X/ NVR0801X P2/NVR1601X P2

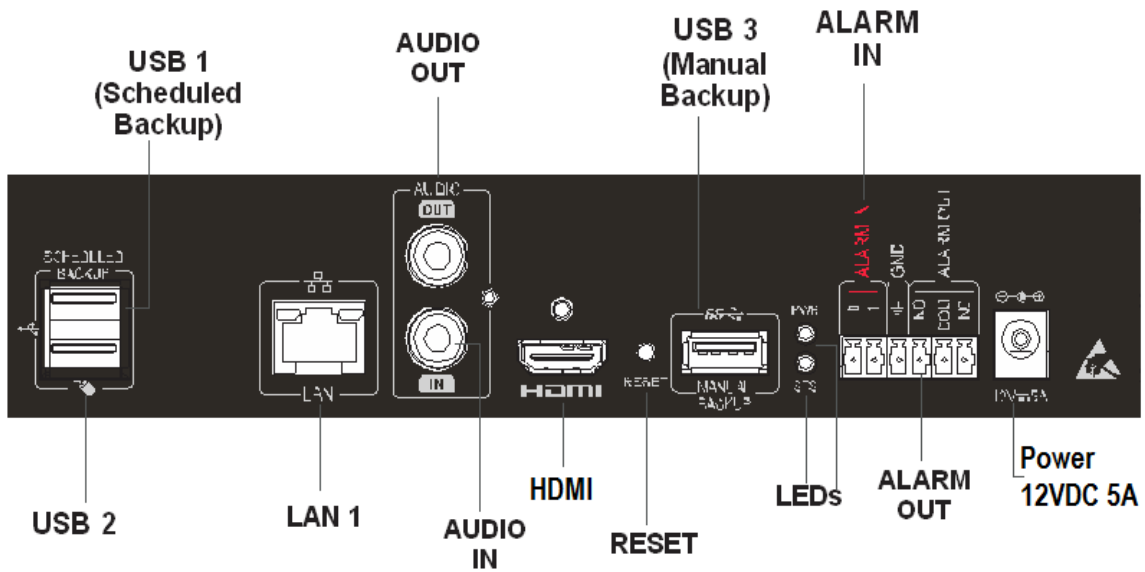

NVR1602X/NVR3202X/NVR1602X P2

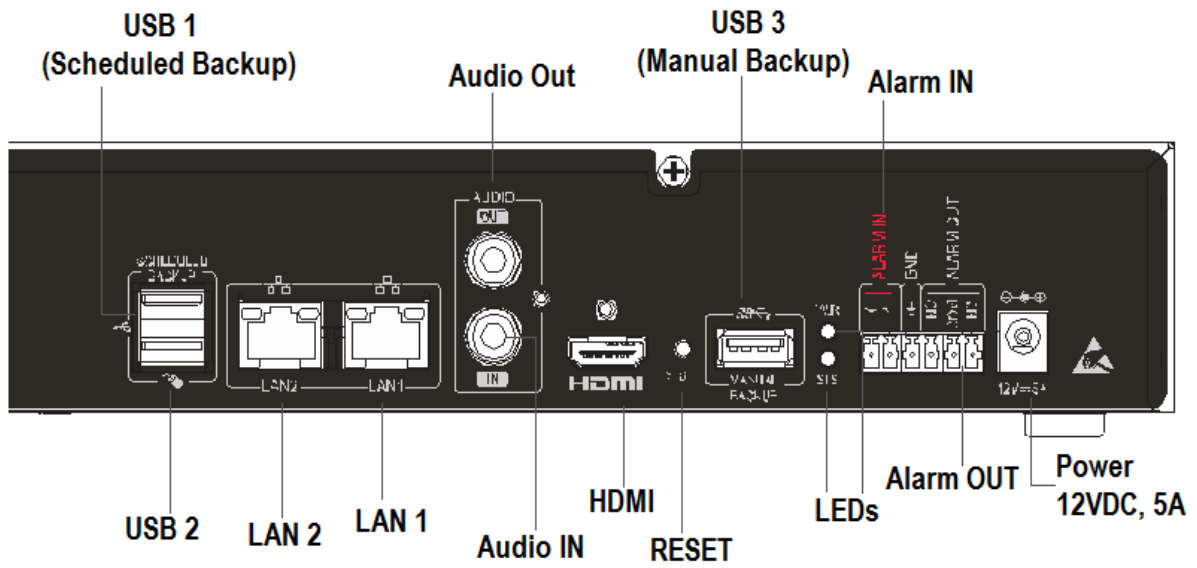

NVR3202X P2

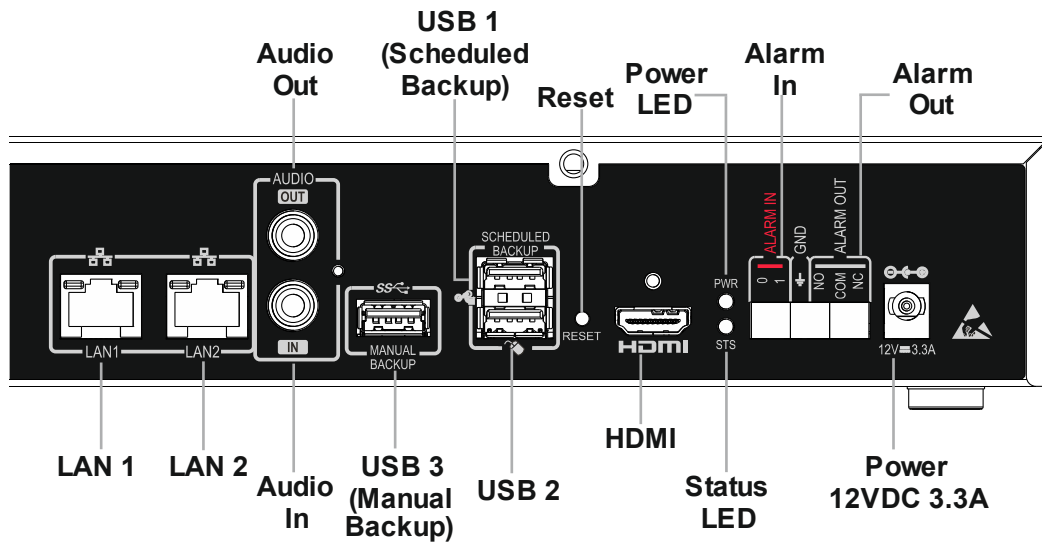

NVR3204X/NVR6404X/NVR6408X

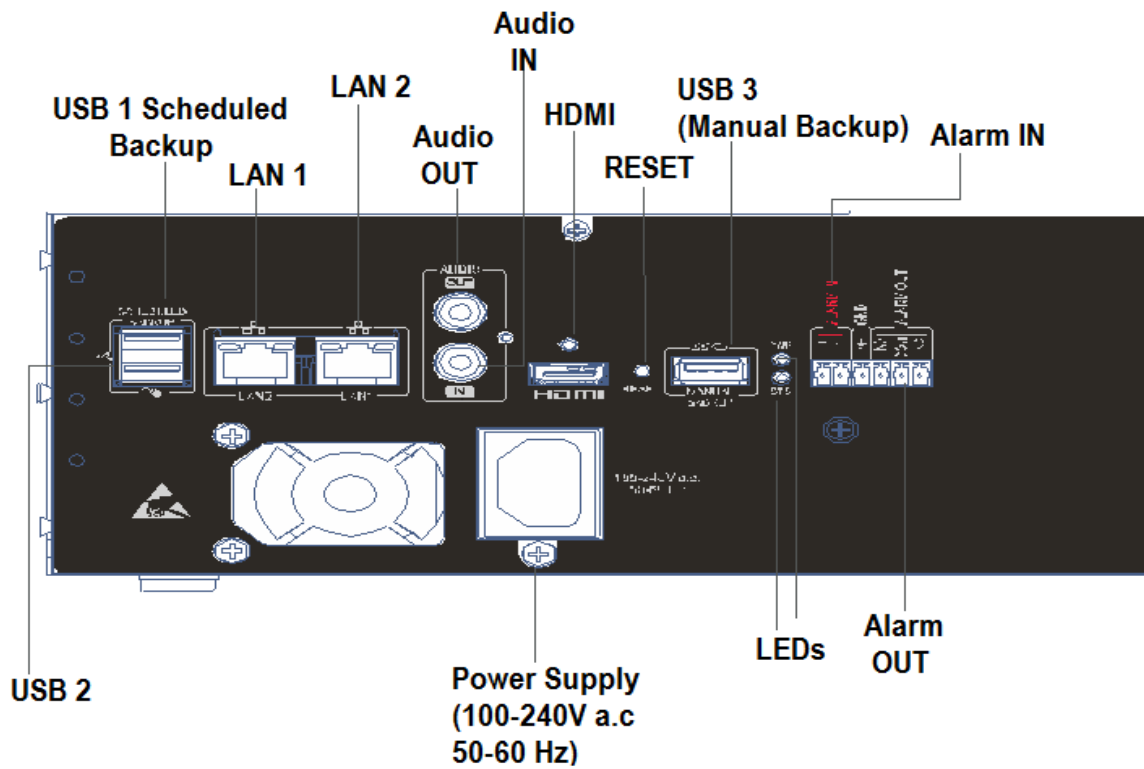

NVR3204X P2/NVR6404X P2/NVR6408X P2/NVR9608X P2

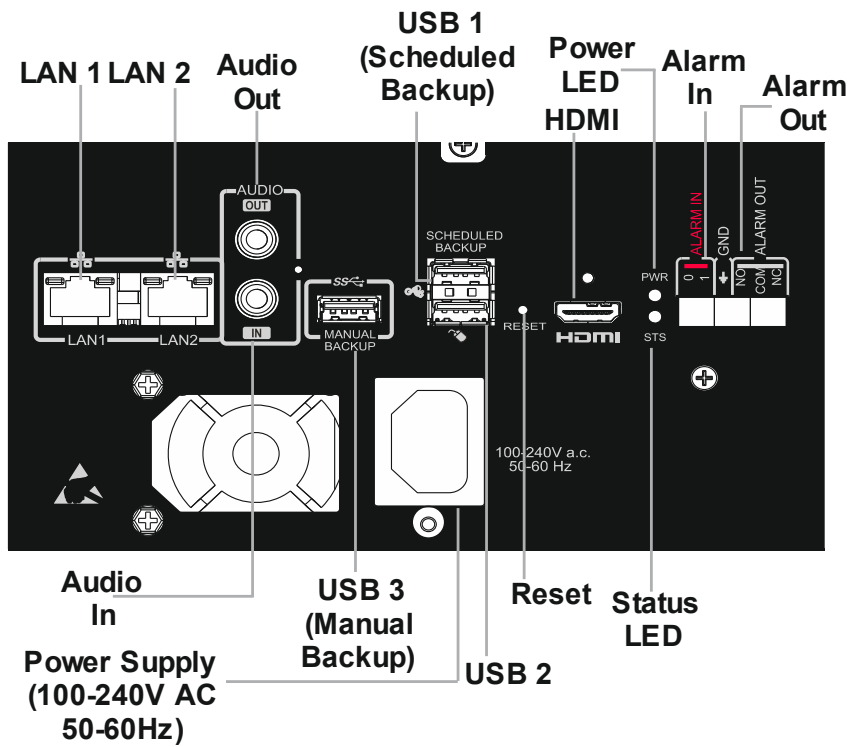

Ports and Connectors of NVRX/NVRX P2 Series

Interface	Description	All Variants
USB 1 (Upper)	USB 2.0, used for Scheduled Backup. To connect USB Mouse and Keyboard. To connect Dongle.	Yes
USB 2 (Lower)	USB 2.0, used to connect USB Mouse and Keyboard. To connect Dongle.	Yes
USB 3	USB 3.0, used for Manual Backup. To connect USB Mouse and Keyboard. To connect Dongle.	Yes
Alarm In (Terminal Block Plug)	To connect a sensor device to detect alarm events.	Yes (2)
Alarm Out (Terminal Block Plug)	To connect an alarm sounding relay device such as a hooter or siren.	Yes (1)
HDMI 2.0	To connect a high definition digital monitor or TV for Main view.	Yes (1)
LAN (RJ45)	To connect a standalone personal computer, or a LAN Switch, or to connect to the Internet over a DSL Modem or Router. Ethernet Speed:10/100/1000Mbps	LAN 1 - Present in all variants LAN 2 - Present in all variants except NVR0801X/NVR0801X P2 and NVR1601X/NVR1601X P2

Interface	Description	All Variants
Audio In (RCA)	To connect audio input device such as a mic.	Yes (1)
Audio Out (RCA)	To connect a low impedance earphone, active sound box or an amplified speaker.	Yes (1)
Reset	<p>Press and hold down the reset button for atleast 4 seconds to default the following parameters.</p> <ul style="list-style-type: none"> • LAN Settings • User Settings • General Settings • Resolution Settings 	Yes

NVRX / NVRX P2 LED And Buzzer State

The NVRX/NVRX P2 (including NVRXS P2) variants has a set of LEDs and Buzzer for indication of events on the SATATYA NVRX/NVRX P2 series. It has been explained in the table below.

State Description	Status LED Cadence	Power LED	Buzzer (System)
Supply is connected but application is not yet initialized.	OFF		N.A.
On Application Initialization	Red 1000 - ON and 1000 – OFF		3000 – ON
System in normal state (Connected to network).	Green 500 - ON and 500 – OFF		N.A.
Storage Incomplete Volume.	Red 1000 ON–5000 OFF		1000 - ON and 5000 – OFF
Storage Full Alert.	Red 2000-ON–2000 OFF		N.A.
Storage Full.	Red 1000 ON–3000 OFF		N.A.
Formatting Disk.	Red 1000 ON–1000 OFF		N.A.
Firmware upgrade in process.	Orange (ON till firmware upgrade process completes)	Green Steady	N.A.
Firmware upgrade failed.	Red 1000 ON–1000 OFF		1000 - ON and 1000 – OFF
Recording failed for 1 or more enabled cameras (Not all)	Orange (500 – ON and 500 – OFF) ON till recording of all enabled cameras gets started		N.A.
Recording failed for all enabled cameras	Red (Steady Light till recording of any one enabled camera gets started)		N.A.
Trigger from Event	Green 500 - ON and 500 – OFF		3000 - ON and 1000 – OFF
Backup Device full	Green 500 - ON and 500 – OFF		1000 - ON and 2000 – OFF
No Backup Device	Green 500 - ON and 500 – OFF		1000 - ON and 3000 – OFF
Temperature reached at 100 degree	Red 500 - ON and 500 – OFF		500 – ON and 5000 – OFF
Temperature reached at 105 degree	System shuts down	Green Steady	N.A.
After crossing 100 degrees, Temperature comes back to less than 100 degree	System automatically comes in normal stage and cadence stops		N.A.

NVR Front Panels

NVR8S

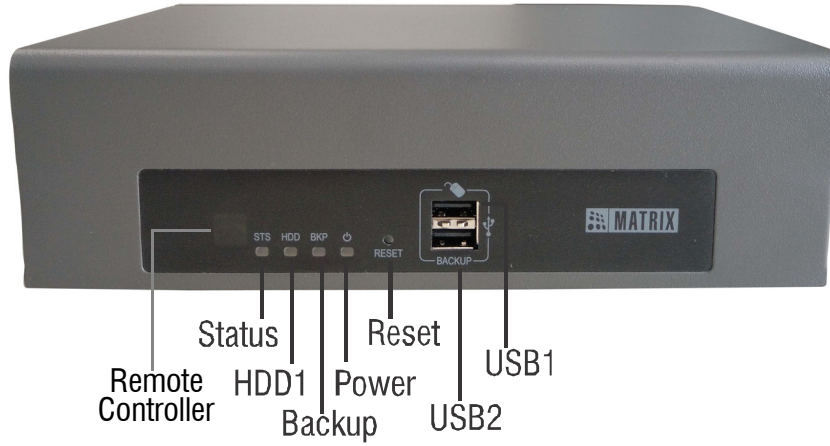

NVR16S

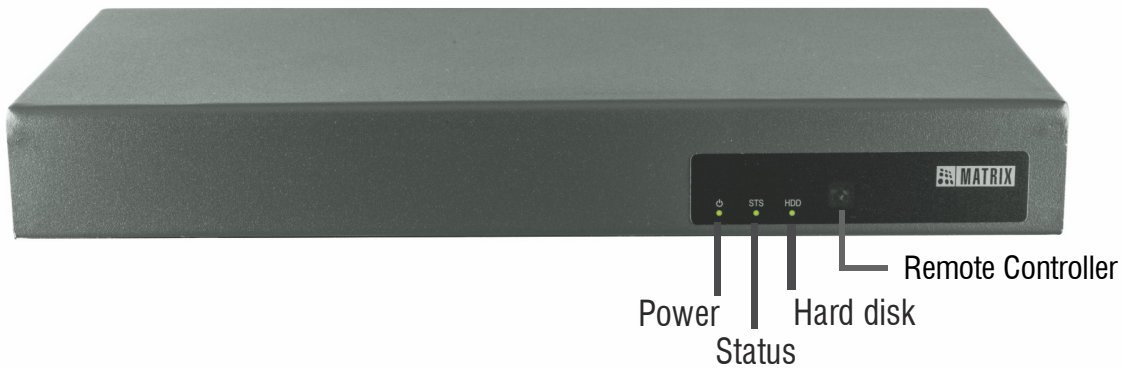

NVR24P



NVR16H



NVR64P/ NVR64S



NVR Front Panel Controls

The front panel of the SATATYA NVR comes with a set of control buttons with the following functionalities.

Interface	Function	NVR8S	NVR16S	NVR24P	NVR16H	NVR64S/P
STATUS	The Status LED to indicate the associated system events.	Yes	Yes	Yes	Yes	No
HDD1	The HDD1 LED to indicate the status of hard disk 1.	Yes	Yes	Yes	No	No
HDD2	The HDD2 LED to indicate the status of hard disk 2.	No	No	Yes	No	No
BACKUP Button	Backup Button to be pressed to start manual backup on the inserted USB device.	No	No	Yes	No	No

Interface	Function	NVR8S	NVR16S	NVR24P	NVR16H	NVR64S/P
BACKUP LED	Backup. LED does not illuminate if backup devices is disconnected	Yes	No	Yes	No	No
POWER Button	Power Button to be pressed to shutdown or restart the device.	No	No	Yes	No	No
POWER LED	The Power LED to indicate the status to indicate the NVR device. LED does not illuminate if the NVR is disconnected from the network.	Yes	Yes	Yes	Yes	No
Remote Controller Sensor	To operate the IR Remote Control.	Yes	Yes	Yes	Yes	No
Reset	Press and hold down the reset button for atleast 4 seconds to default the following parameters. <ul style="list-style-type: none"> • LAN Settings • User Settings. • General Settings • Resolution Settings 	Yes	No	No	No	No

NVR Front Panel USB Connections

Interface	NVR8S	NVR16S	NVR24P	NVR16H	NVR64S/P
USB 1	Yes (Mouse, Dongle)	No	Yes (Schedule Backup)	Yes (Mouse)	No
USB 2	Yes (Backup)	No	Yes (Manual Backup)	Yes (Manual Backup)	No
USB 3	No	No	Yes	No	No
USB 4	No	No	Yes	No	No



USB 1-4: Defined for Front Panel.

USB 5-6: Defined for Rear Panel (Explained in Rear Panel section).

NVR Rear Panel

NVR8S

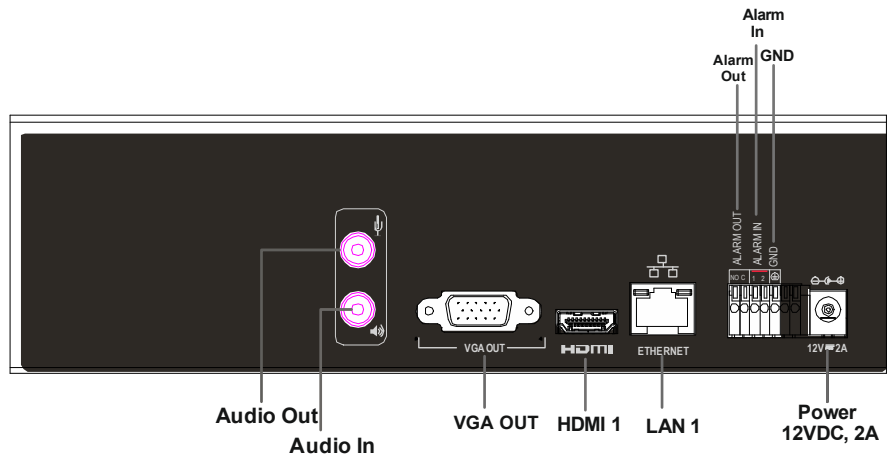

NVR16S

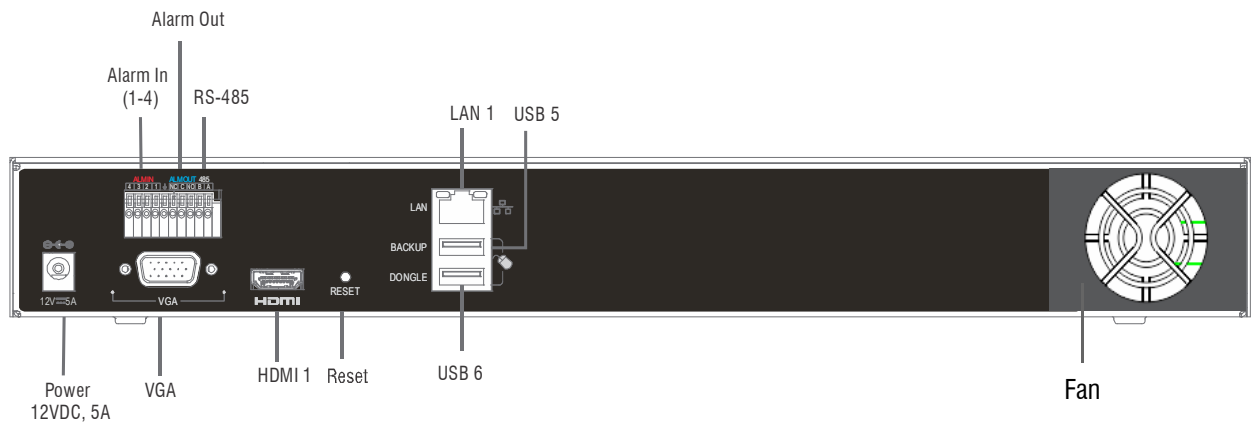

NVR24P

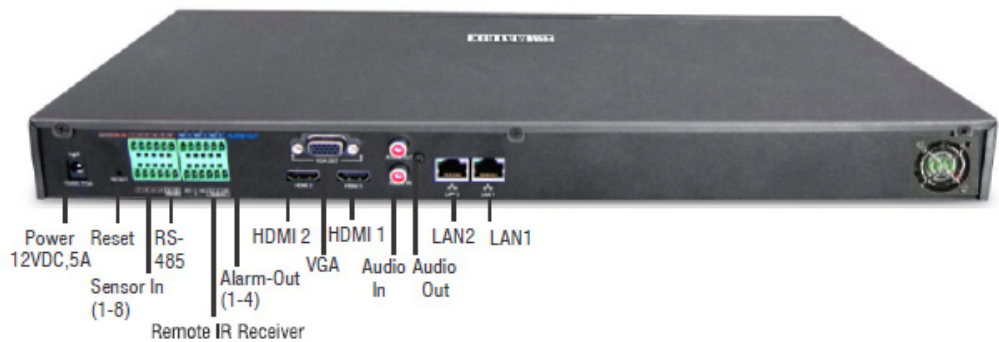

NVR16H

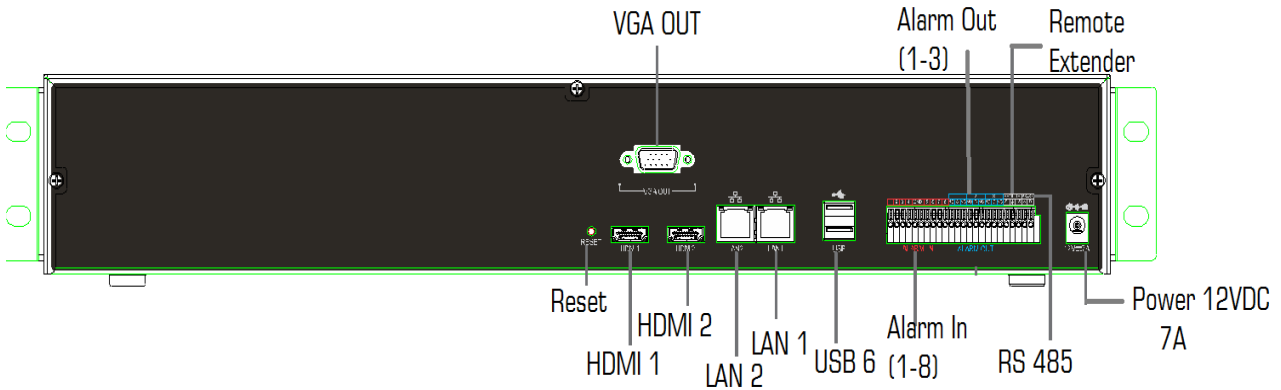

NVR64P/NVR64S

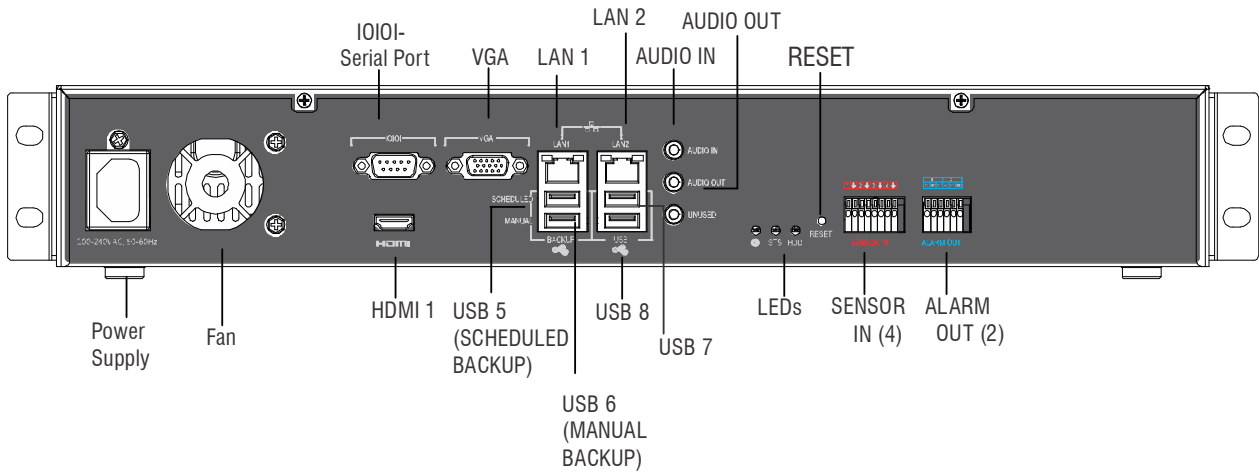

NVR Rear Panel Controls

Interface	Description	NVR8S	NVR16S	NVR24P	NVR16H	NVR64S/P
Power supply	To connect AC/DC power supply as specified.	12 VDC, 2A	12 VDC, 5A	12 VDC, 5A	12 VDC, 7A	To connect 100-240 VAC, 50-60Hz
Sensor In/ Alarm In (Terminal Block Plug)	To connect a sensor device to detect alarm events.	Yes (2)	Yes (4)	Yes (8)	Yes (8)	Yes (4)
Alarm Out (Terminal Block Plug)	To connect an alarm sounding relay device such as a hooter or siren.	Yes (1)	Yes (1)	Yes (4)	Yes (3)	Yes (2)

Interface	Description	NVR8S	NVR16S	NVR24P	NVR16H	NVR64S/P
Remote Extender (Terminal Block Plug)	To connect a Remote IR Receiver.	No	No	Yes	Yes	No
HDMI 1 (MAIN)	To connect a high definition digital monitor or TV for Main view.	Yes	Yes	Yes	Yes	Yes
HDMI 2 (SPOT)	To connect a high definition digital monitor or TV for Spot view.	No	No	Yes	Yes	No
LAN 1 (RJ45)	To connect a standalone personal computer, or a LAN Switch, or to connect to the Internet over a DSL Modem or Router.	Yes	Yes	Yes	Yes	Yes
LAN 2 (RJ45)	To connect a standalone personal computer, or a LAN Switch, or to connect to the Internet over a DSL Modem or Router.	No	No	Yes	Yes	Yes
VGA Out (VGA)	To connect a VGA type monitor (LCD monitor of a personal computer) for local viewing; to access NVR controls and configuration settings from the display.	Yes	Yes	Yes	Yes	Yes
Audio In (RCA)	To connect audio input device such as a mic.	Yes	No	Yes	No	Yes
Audio Out (RCA)	To connect a low impedance earphone, active sound box or an amplified speaker.	Yes	No	Yes	No	Yes
Reset	Press and hold down the reset button for atleast 4 seconds to default the following parameters. <ul style="list-style-type: none"> • LAN Settings • User Settings • General Settings • Resolution Settings 	No	Yes	Yes	Yes	Yes

 *RS485 is available in NVR16S, NVR24P, NVR16H, which is not in use.*

NVR Rear Panel USB Connections

Interface	NVR8S	NVR16S	NVR24P	NVR16H	NVR64S/P
USB 5	No	Yes (Backup)	No	Yes	Yes (Scheduled Backup)
USB 6	No	Yes (Dongle)	No	Yes	Yes (Backup)
USB 7	No	No	No	No	Yes
USB 8	No	No	No	No	Yes

 *USB 1-4: Defined for Front Panel (Explained in Front Panel section).
USB 5-6: Defined for Rear Panel.*

SATATYA Hybrid Video Recorder (HVR)

SATATYA Hybrid Video Recorder includes variants such as **HVR 1624P/ HVR 1624S**, **HVR 0824P/ HVR 0824S** and **HVR 0408P/ HVR 0408S**. Click on the following to know about the Front and Rear Panel connectors of each HVR variant.

[“HVR Front Panels”](#)

[“HVR Rear Panel”](#)

HVR Front Panels

HVR16/8P

(HVR 1624P and HVR 0824P)

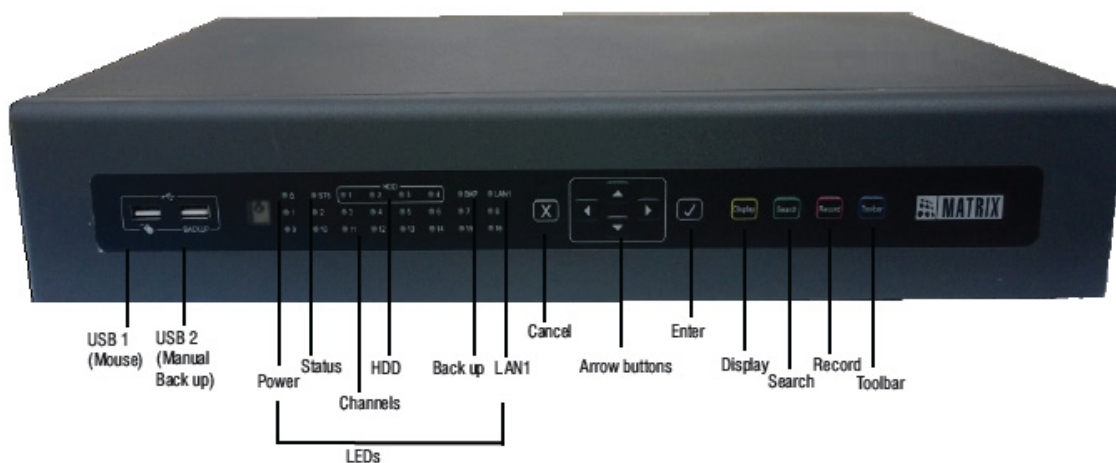

HVR16/8S

(HVR 1624S and HVR 0824S)



HVR 0408P

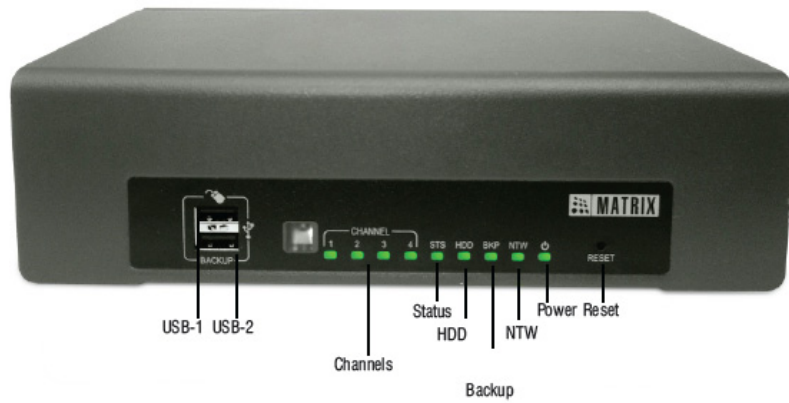

HVR 0408S

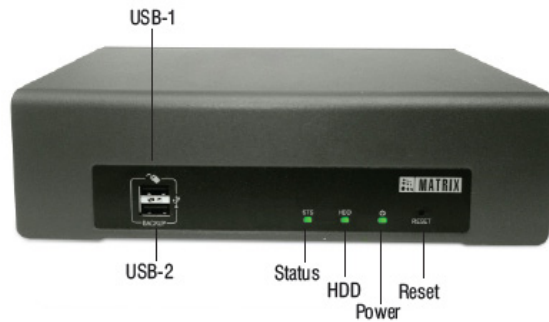

HVR Front Panel Controls

The front panel of the SATATYA HVR comes with a set of control buttons with the following functionalities

Name	Function	HVR 1624P	HVR 1624S	HVR 0824P	HVR 0824S	HVR 0408P	HVR 0408S
USB port 1	To connect USB Mouse, external USB storage device	USB Mouse	No	USB Mouse	No	USB Mouse, dongle and Manual backup.	USB Mouse, dongle and Manual backup.
USB port 2/ Backup	To connect external USB storage device.	Manual backup	No	Manual backup	No	USB Mouse, Scheduled backup	USB Mouse, Scheduled backup
USB port 3	To connect USB Mouse, external USB storage device	No	No	No	No	No	No

Name	Function	HVR 1624P	HVR 1624S	HVR 0824P	HVR 0824S	HVR 0408P	HVR 0408S
USB port 4	To connect USB Mouse, external USB storage device	No	No	No	No	No	No
Display	Loads Display Layout list on the screen. This button is also mapped to the Default button on the menu screens.	Yes	No	Yes	No	No	No
Search	Loads the Playback Search option for recorded files. This button is also mapped to the Refresh button on the menu screens.	Yes	No	Yes	No	No	No
Record	Starts the manual recording. This button is also mapped to the Save button on the menu screens.	Yes	No	Yes	No	No	No
Toolbar	Loads the tool bar on the local display and navigates to different Configuration options.	Yes	No	Yes	No	No	No
Enter button	Press to select desired menu item, to select highlighted option from the virtual keyboard. This button is also used to load the menu list over the selected monitoring window.	Yes	No	Yes	No	No	No

Name	Function	HVR 1624P	HVR 1624S	HVR 0824P	HVR 0824S	HVR 0408P	HVR 0408S
Left right Arrow keys	To navigate between the options after selecting a menu item. Also used to navigate between the monitoring windows or set of channels in the event of default layout template being loaded. Also used to navigate on the virtual keyboard.	Yes	No	Yes	No	No	No
Up Down Arrow Keys	To scroll through the various values available for each parameter of a functionality. Also used to navigate on the virtual keyboard.	Yes	No	Yes	No	No	No
Cancel	Highlights the Cancel button to exit an interface. It is also used to return from the full screen view of a particular channel to the selected layout. It is also used to unload the menu list over the selected the window.	Yes	No	Yes	No	No	No
Reset	Press and hold down the reset button for atleast 4 seconds to default the following parameters. <ul style="list-style-type: none"> • LAN Settings • User Settings • General Settings • Resolution Settings 	No	No	No	No	Yes	Yes

HVR Rear Panel

HVR 1624P

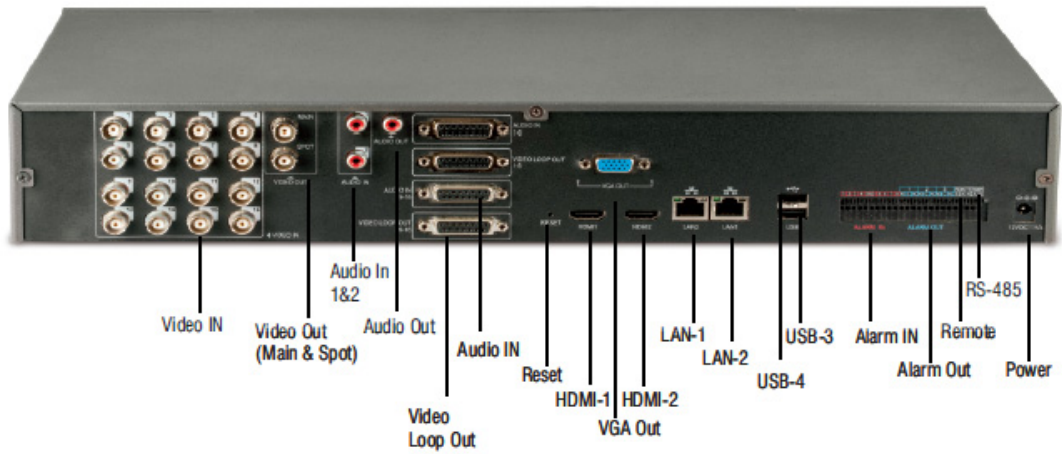

HVR 1624S



HVR 0824P

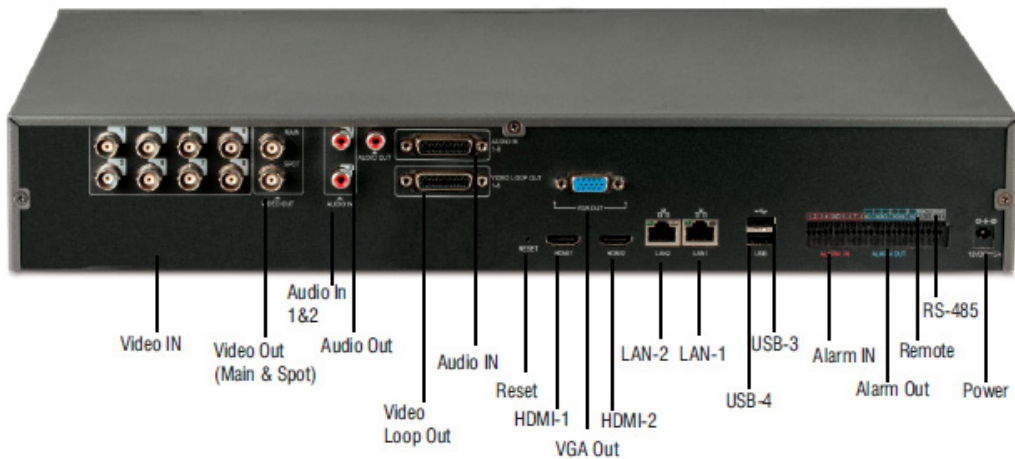

HVR 0824S



HVR 0408P

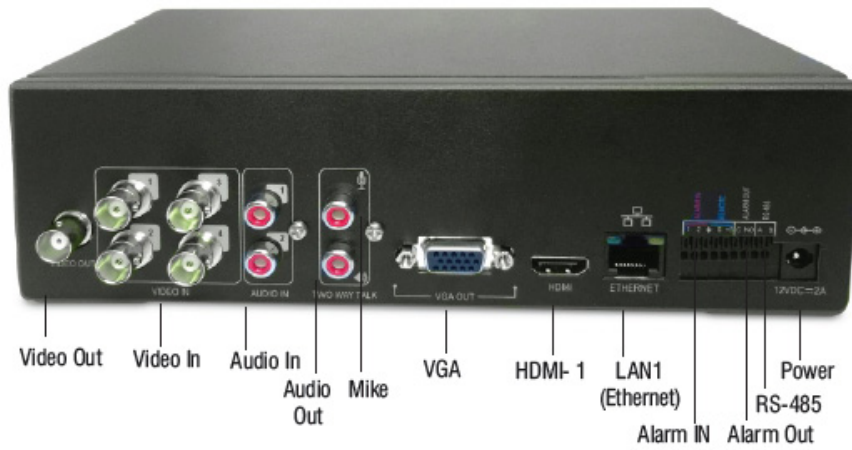

HVR 0408S

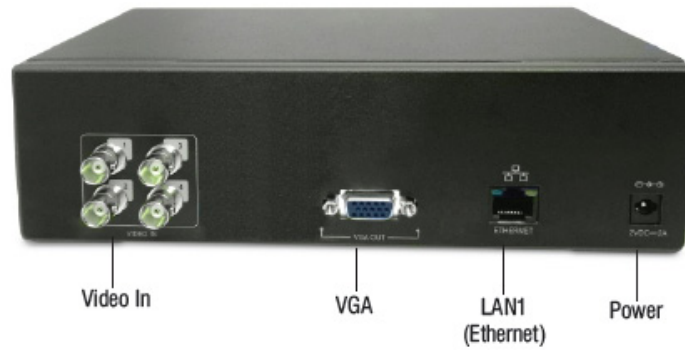

HVR Rear Panel Controls

Interface	Description	HVR 1624P	HVR 1624S	HVR 0824P	HVR 0824S	HVR 0408P	HVR 0408S
Power	To connect Power Supply 12VDC or AC	Yes (7A)	Yes (5A)	Yes (7A)	Yes (5A)	Yes (2A)	Yes (2A)
Reset	Press and hold down the reset button for atleast 4 seconds to default the following parameters. <ul style="list-style-type: none"> • LAN Settings • User Settings • General Settings • Resolution Settings 	Yes	Yes	Yes	Yes	No	No
Alarm In	To connect a sensor device to detect alarm events.	Yes(8)	Yes(4)	Yes(8)	Yes(4)	Yes(2)	No
Alarm Out	To connect an alarm sounding relay device such as a hooter or siren.	Yes(3)	Yes(1)	Yes(3)	Yes(1)	Yes(1)	No
Remote Extender	To connect a Remote IR Receiver.	Yes	No	Yes	No	Yes	No
RS 485	The PTZ cameras can be connected to the A and B ports of device in RS485 loop. The dip switches on the PTZ cameras are used to set the RS485 address of the cameras.	Yes	Yes	Yes	Yes	Yes	No
HDMI 1 (MAIN)	To connect a high definition digital monitor or TV for Main view.	Yes	Yes	Yes	Yes	Yes	No
HDMI 2 (SPOT)	To connect a high definition digital monitor or TV for Spot view	Yes	No	Yes	No	No	No

Interface	Description	HVR 1624P	HVR 1624S	HVR 0824P	HVR 0824S	HVR 0408P	HVR 0408S
LAN 1	To connect a standalone personal computer, or a LAN Switch, or to connect to the Internet over a DSL Modem or Router.	Yes	Yes	Yes	Yes	Yes	Yes
LAN 2	To connect a standalone personal computer, or a LAN Switch, or to connect to the Internet over a DSL Modem or Router.	Yes	No	Yes	No	No	No
USB -Up	The USB upper port is used for connecting mouse, GSM dongle or Manual Backup	Mouse, GSM Dongle	Mouse, Manual Backup	Mouse, GSM Dongle	Mouse, Manual Backup	No	No
USB -Down	The USB lower port is used for connecting the USB Flash drive for Scheduled back up.	Mouse, Scheduled Backup	Mouse, GSM Dongle, Scheduled Backup	Mouse, Scheduled Backup	Mouse, GSM Dongle, Scheduled Backup	No	No
USB-3	The USB upper right port in NVR64	No	No	No	No	No	No
USB-4	The USB lower right port in NVR64	No	No	No	No	No	No
VGA Out	To connect a VGA type monitor (LCD monitor of a personal computer) for local viewing; to access HVR controls and configuration settings from the display.	Yes	Yes	Yes	Yes	Yes	Yes
Audio In	To connect audio input device such as a mic.	Yes	Yes	Yes	Yes	Yes	No

Interface	Description	HVR 1624P	HVR 1624S	HVR 0824P	HVR 0824S	HVR 0408P	HVR 0408S
Audio Out	To connect a low impedance earphone, active sound box or an amplified speaker.	Yes	Yes	Yes	Yes	Yes	No
Two-way Talk	Used for two-way audio communication	No	No	No	No	Yes	No
Video Out-Main	The "Main" BNC Connector is used to connect a CVBS monitor for local viewing, to access HVR controls and configuration settings from the display.	Yes	No	Yes	No	No	No
Video Out-Spot	The "Spot" BNC connector is used to connect a CVBS monitor configured for local viewing only.	Yes	Yes	Yes	Yes	Yes	No
Video Inputs	These are used to connect standard PAL or NTSC Analog video cameras.	Yes	Yes	Yes	Yes	Yes	Yes
Audio In (1-8)	First to eight channel audio input DB-15 port can be used to connect multiple audio inputs.	Yes	No	Yes	No	No	No
Audio In (9-16)	First to eight channel audio input DB-15 port can be used to connect multiple audio inputs.	Yes	No	No	No	No	No
Video Loop Out (1-8):	These output provide loop through connections, and can be used for direct monitoring of connected video cameras.	Yes	No	Yes	No	No	No

Interface	Description	HVR 1624P	HVR 1624S	HVR 0824P	HVR 0824S	HVR 0408P	HVR 0408S
Video Loop Out (9-16):	These output provide loop through connections, and can be used for direct monitoring of connected video cameras.	Yes	No	No	No	No	No

 In HVR16/8S and HVR4 channel, there is only one LAN/ Ethernet port so consider as LAN1 and HDMI port as HDMI1 in this document.

 The HDMI (Main) port used for connecting a high definition digital monitor or TV for Main view automatically checks the supported resolution with the available resolutions and sets the HDMI resolution accordingly.

For detailed description on connection with the interfaces See [“Connecting the Device”](#) on page 45.

Front Panel LED Details (For other NVR and HVR Variants)

The front panel also provides LED indications based on the status of various parameters as well as events happening at the device.

LED	Function	Color	Cadence	Description
Power Button	Power Button to be pressed to shutdown or restart the device.	Green	1000 ON–3000 OFF	Supply connected but application not initialized.
		Green	500 ON–500 OFF	Application initialization.
		Green	Steady	Idle State.
Status	The Status LED to indicate the associated system events.	Green	3000 ON–1000 OFF	System in normal state.
		Orange	1000 ON–5000 OFF	Incomplete Volume.
			2000 ON–2000 OFF	Storage Alert.
			1000 ON–3000 OFF	Disk Full.
		Red	1000 ON–1000 OFF	Formatting Disk.
		Red	1000 ON–2000 OFF	Firmware upgrade in progress.
HDD1/ HDD2	The HDD LED to indicate the status of hard disk.	Red	1000 ON–1000 OFF	Firmware upgrade failed.
		Green	Steady	Disk normal.
		Green	1000 ON–2000 OFF	Disk error.
Backup Button	Backup Button to be pressed to start manual backup on the inserted USB device.	NA	LED is not illuminated	No disk.
		NA	LED is not illuminated	No backup device connected.
		Green	Steady ON	Device ready for backup.
		Green	2000 ON–2000 OFF	Backup in progress.
		Green	1000 ON–3000 OFF	Backup is disabled.
		Green	1000 ON–2000 OFF	Backup device is full.
LAN 1 LED/ NTW	The LAN LED to indicate the status of network.	Green	1000 ON–1000 OFF	Formatting backup device.
		Green	Steady	HVR is connected to the network
		Green	LED is not illuminated	HVR is disconnected from the network

LED	Function	Color	Cadence	Description
Channel		Green	Steady	Camera is connected to the respective channel

Status LED Cadence in NVR64S/P

State Description	Status LED Cadence	Power LED	Buzzer (System)
Supply is connected but application is not yet initialized.	OFF		N.A.
On Application Initialization	Red 1000 - ON and 1000 – OFF		3000 – ON
System in normal state (Connected to network).	Green 3000 - ON and 1000 – OFF		N.A.
Storage Incomplete Volume.	Orange 1000 ON and 5000 OFF		1000 - ON and 5000 – OFF
Storage Full Alert.	Orange 2000-ON and 2000 OFF		N.A.
Storage Full.	Orange 1000 ON and 3000 OFF	Green Steady	N.A.
Formatting Disk.	Orange 1000 ON and 1000 OFF (Continue cycle until disk is formatted)		N.A.
Firmware upgrade in process.	Red 1000 - ON and 2000 – OFF (Continue Cycle till process completion)		N.A.
Firmware upgrade failed.	Red 1000 - ON and 1000 – OFF (30 cycles)		1000 - ON and 1000 – OFF
Trigger from Event	N.A.	N.A.	3000 - ON and 1000 – OFF
Disk Normal	Green 3000 - ON and 1000 – OFF		N.A.
Disk Error	Green 3000 - ON and 1000 – OFF	Green Steady	N.A.
No Disk	Green 3000 - ON and 1000 – OFF		N.A.

Installation Precautions

It is very important for the installer to read and understand all the instructions in this manual before starting the installation process. For each stage in the installation and commissioning procedure of device, a brief description is given of its purpose, complete with detail drawings, flow diagrams and/or other graphics, wherever possible, to make the instructions easy to follow. Before installing the SATATYA device, you must first check the Product and ensure that the following criteria have been met. Failure to do so may not only result in damage to the equipment, but may also cause problems when commissioning the system and may adversely affect its performance.

Product Inspection

The SATATYA devices are simple to install and commission if the procedures as described in the Installation and Commissioning sections of this manual, are followed.



Follow all installation instructions described in this manual. These instructions must be understood and followed to avoid damage to the system and associated equipment.

Before Installation verify contents of the package shipped to you with the contents listed below. If any of the items is missing or damaged, contact your Dealer/Reseller. Unpack the system. Make sure that your package contains all the below items along with the SATATYA device.

NVRX/NVRX P2 Variants Package Contents

Contents	NVR0401XS P2/ NVR0801XS P2/ NVR1601XS P2	NVR0801X/ NVR1601X NVR0801X P2/ NVR1601X P2	NVR1602X/ NVR3202X NVR1602X P2/ NVR3202X P2	NVR3204X/ NVR6404X/ NVR3204X P2 / NVR6404X P2	NVR6408X/ NVR6408X P2/ NVR9608X P2
Adapter 12VDC	Yes (2A)	Yes (5A)	Yes (5A)	SMPS	SMPS
SATA Power Cable	1	1	2	NA	NA
SATA Data Cable	1	1	2	4	8
1 Cable mains MC-4 3 Pin	NA	NA	NA	Yes	Yes
HDD fitting screws M6/ 32 PAN PH	3	4	8	16	32
USB Mouse	Yes	Yes	Yes	Yes	Yes

Contents	NVR0401XS P2/ NVR0801XS P2/ NVR1601XS P2	NVR0801X/ NVR1601X NVR0801X P2/ NVR1601X P2	NVR1602X/ NVR3202X NVR1602X P2/ NVR3202X P2	NVR3204X/ NVR6404X/ NVR3204X P2 / NVR6404X P2	NVR6408X/ NVR6408X P2/ NVR9608X P2
Side Clamps for Rack Mounting	No	No	Yes	Yes	Yes
Alarm Out Terminal Plug	No	Yes	Yes	Yes	Yes

Other NVR Variants Package Contents

Contents	NVR8S	NVR16S	NVR24P	NVR16H	NVR64P/S
Adapter 12VDC	Yes (2A)	Yes (5A)	Yes (5A)	Yes (7A)	NA
SATA Power Cable	1	1	1	2	NA
SATA Data Cable	1	1	2	4	4
IO Connector	NA	NA	4	NA	NA
1 Cable mains MC-4 3 Pin	NA	Yes	Yes	Yes	Yes
HDD fitting screws M6/32 PAN PH	6	2	8	16	19
Wall mounting screw M5/25 CSK PH + screw grip	2	NA	NA	NA	NA
USB Mouse	Yes	Yes	Yes	Yes	Yes
Side Clamps for Rack Mounting	NA	NA	Yes	Yes	Yes
Screws for the Side Clamps	NA	NA	Yes	No	Yes

HVR Variants Package Contents

Contents	HVR1624P	HVR1624S	HVR0824P	HVR0824S	HVR0408P	HVR0408S
Adapter 12VDC	Yes (7A)	Yes (5A)	Yes (7A)	Yes (5A)	Yes (2A)	Yes (2A)
SATA Power Cable	2	1	2	1	1	1
SATA Data Cable	4	1	4	1	1	1
IO Connector	NA	NA	NA	NA	NA	NA
Remote controller	Yes	Yes	Yes	Yes	Yes	No
1 Cable mains MC-4 3 Pin	Yes	Yes	Yes	Yes	NA	NA
HDD fitting screws M6/32 PAN PH	16	2	16	2	3	3

Contents	HVR1624P	HVR1624S	HVR0824P	HVR0824S	HVR0408P	HVR0408S
Wall mounting screw M5/25 CSK PH + screw grip	NA	NA	NA	NA	2	2
USB Mouse	Yes	Yes	Yes	Yes	Yes	Yes
Side Clamps for Rack Mounting	Yes	NA	Yes	NA	NA	NA
Screws for the Side Clamps	Yes	NA	Yes	NA	NA	NA

Safety Instructions

- The Matrix device is intended for indoor use only. Equipment must thus be installed into a controlled, dry, clean and secure environment where temperature and humidity are within product specifications.
- Use the power cord which is supplied along with the equipment. Ensure adequate earthing at the installation site.
- Do not dismantle the equipment.
- The SATATYA device can be either mounted on a table, wall or a rack for allowing clear visibility of displays and easy access to operating controls.
- Do not touch the product with wet hands.
- Do not locate the SATATYA devices where there are high levels of vibration or shock.
- Equipment must be installed by a trained professional.
- Prevent metallic, foreign or liquid substances from getting inside the product. This includes insecticide or flammable cleaning spray.
- Make sure the vent holes are not covered with any item such as newspaper, cloth or curtains. The openings should never be blocked.
- There should be at least some space, that is, 3 to 4 inches around the system for air circulation.
- In stack mounting condition, there should be minimum 1 to 2 inches air gap between two systems (bottom and top).
- Make sure the ambient temperature for the systems is below operating temperature of the system (40 degree centigrade) day and night.
- Installation of the system should be away from heat sources and direct sunlight and dust free environment.
- Make sure no objects are stacked on the system.
- Make sure the other appliances/devices that need to be connected with the network video recorder are connected through electrical surge protection power plugs or SPD (Surge protection devices) having longitudinal and metallic surge protection.

- Use good quality shielded HDMI cable. There should be electrical continuity between HDMI connector body shell at both the ends.
- Matrix video recording systems should always be installed with factory shipped 12V Power Adapter.
- Do not run HDMI cables along AC power cables. Power and signal cables should run separate.
- Ensure that cables are gently inserted while installation or changing cables and do not force or twist cables while inserted into the HDMI socket on your LCD or distribution equipment.
- Make sure the site's electrical system is properly grounded (earthing) before connecting to the power supply.
- Make sure the system is out of reach of children.

Preventive Measures

- The installer should always take basic safety instructions to reduce the risk of fire, electric shock and injury to personnel and system.
- The SATATYA device should be installed and used within a pollution free environment and at a safe and secure indoor location. Never install the device during a lightening storm.
- The equipment is to be installed or served by authorized Service Persons only. The SATATYA device comes installed in a metallic cabinet. Make sure the you disconnect the power before servicing.
- Do not place the product at a location from where it can fall and cause damage to the product.
- Install the SATATYA device away from Electromagnetic Inducing (EMI) equipment, such as electrical generators, motors, and high voltage cables.
- The product should be operated with appropriate power voltage supply as mentioned in the specification sheet.
- The system needs to have a clean and uninhibited air flow round the equipment as air is circulated throughout the unit.
- Ensure that appropriate ambient temperature is maintained. Excessive internal temperature can harm the system.
- Make sure the site has the necessary earthing done.
- Ensure appropriate mains filtering and UPS are used in areas where the power source is susceptible. Damage through power source fluctuations, spikes, etc. is not covered by warranty.
- Install the SATATYA device in a stable and level location.
- There are **no serviceable parts within the equipment**. For any issues or queries regarding the equipment please contact your installer.
- Unplug this unit during lightning storms or when unused for long periods of time.

- Once installed and running do not cut off the power or move the unit when hard drives are operating. Doing so may cause damage and loss of data.
- Once running, you may feel the surface of the NVRXS enclosure is hot. This is normal as the heat generated by HDD (Hard Disk) and electronic components is dissipated on the NVRXS enclosure body. Be careful when you come in contact the surface of the NVRXS enclosure.

Checking the Packaging and its Contents

Before attempting to install your SATATYA device, you should do the following:

After removing the equipment from its packaging, and before proceeding with the installation, check for any damage that may have been caused during transit. Any missing item/part or damaged component should be reported immediately.



*In the unlikely event that any of the components has been damaged in transit, you **MUST NOT** install it but contact your supplier for their returns procedure.*

Reporting Suspected Device Damaged

The procedure described below tells you what to do in the unlikely event that the supplied equipment has been damaged after leaving the factory. However, if you have problems regarding the quality of any of the supplied order items including the SATATYA device or its ancillaries, or items are missing, follow the procedure below.

- If, after removing the SATATYA device from its packaging, a visual inspection reveals that it has been damaged, you **MUST NOT** continue with the installation but contact your supplier for advice on what to do next. Similarly, if the product is found to be faulty during installation contact your supplier immediately.
- To aid your supplier you are requested to note all the details relevant to your complaint, clearly stating details of any technical problems, date of receipt, packaging condition, etc. and forward this to your supplier.
- Where the product needs to be returned to your supplier, you are requested to use the original packaging wherever possible.

Typical SATATYA Device Installation layout

The Network layout of a typical installation of HVR is shown here. Similarly the installation of NVR supports IP cameras and HVR supports both Analog and IP cameras.

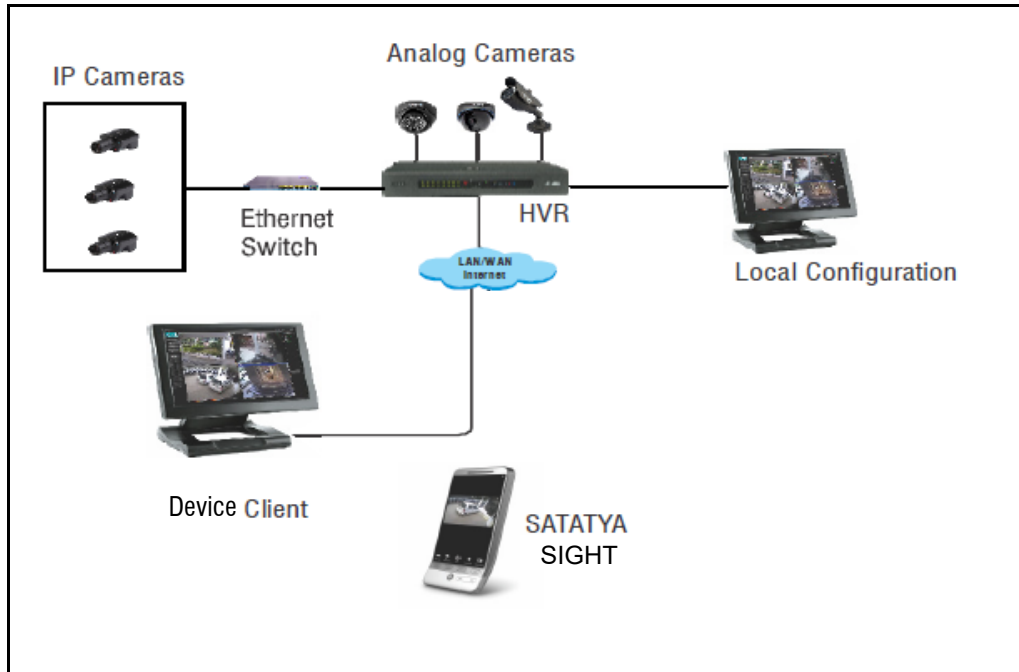

SATATYA device offers you three options for Remote View: Device Client, Mobile Viewer (SATATYA SIGHT) through Inter-networking.

Device Client

The Device Client enables access to live and stored video images of SATATYA device from a remote location through the Web. Using the Device Client you can access, search, browse, display and transfer stored video to a remotely connected workstation. You can configure the device and camera settings, receive notification of events such as alarm, motion/no motion detection and video loss.

SATATYA SIGHT

SATATYA SIGHT is a mobile application which supports live view of the channels and allows the user to view the live recordings any time, anywhere, on your smart devices

SATATYA SIGHT supports Android, Windows and iOS-based devices.

To know more, user can refer *FAQs for Android, Windows and iOS* respectively.

For **Local configuration**, See [“Local configuration of the SATATYA Device” on page 121](#).

Installing the SATATYA Device

Physical Installation

- Review the SATATYA device layout, cable runs, and power needs.
- Place the device unit at an appropriate location in line with the requirements as specified earlier.
- Connect the LAN cables in the RJ-45 jack connectors.
- Connect external sensors or dry contact relays of other devices directly to the input ports if required.
- Connect external alarm devices to the relay outputs if required.
- An HDMI monitor can be connected to the HDMI port of device. The HDMI monitor can display the same image(s) as seen on the VGA Monitor as well as the user menus.

Selecting an Installation Location

The SATATYA device should be installed at a secured location in an environment providing normal temperature and humidity levels.

The Operating Temperature NVRX/NVRX P2 variants should be between 0°C to +50°C (32°F to 122°F).

The Operating Temperature for NVRXS P2 variants should be between 0°C to +45°C (32°F to 113°F).

The Humidity Level (for all variants) should be between 5% to 95% RH Non condensing.

Place the SATATYA device on a level surface. Do not use it on a wobbling or inclined stand.

Stay away from electrical or communication devices: The SATATYA devices must be located at a minimum distance of 2 m (6 feet) from any high voltage equipment or wiring (> 230 Volts) and from electrical equipment susceptible of generating electrical interference.

Do not Install near any heat sources such as radiators, heat registers, stoves or other apparatus that produce heat. Excessive heat can shorten the life of electronics.

Install the device away from direct sunlight.

Connecting the Device



All wiring as described in this section should comply with the applicable local wiring regulations.

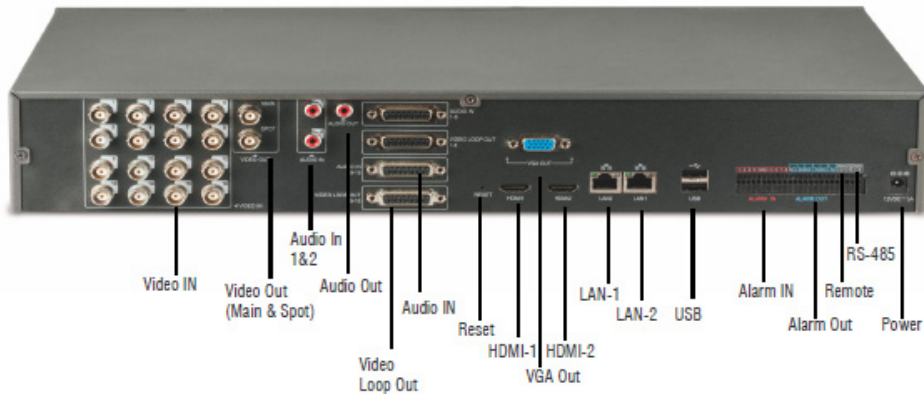

The above figure displays the connectors on the rear face of the SATATYA HVR1624P. For the availability of connectors in other devices, see **Ports and Connectors** in See “System Architecture” on page 11.

Connectors	Description
DC 12V	Apply 12 VDC using a DC switching adapter.
Alarm Sensor Inputs	Connect the external sensor devices to signal the SATATYA NVR,HVR to react to the events. For details See “Hooking up Inputs” on page 90.
Sensor Outputs	An internal relay connects/closes the two connected external sensor output terminals. The relay can be triggered to close the two sensor connections by either motion or a sensor input, if enabled in the Device I/O Settings. This can be used to turn on or off an external buzzer or light. When using the Relay outputs, ensure the voltage/current capacity of the relays are not exceeded.
Remote IR receiver	In the event of placing the device display away from the device NVR/HVR, the installer can connect a remote IR receiver to access the SATATYA device controls. Connect the three conductors from a remote IR receiver unit to the appropriate terminals.
Ethernet	Connect the LAN cables to the RJ -45 jack connectors
HDMI Ports	This is provided to connect HDMI displays to the SATATYA device if required. One connector (HDMI 1) is used as the main video output with local video display and menu operations. And other connector (HDMI 2) is used for Spot video Output.  <i>In this manual, the “Local Client” has been used to term HDMI (video) Out.</i>

Connectors	Description
VGA	<p>Connect to a VGA monitor. The cable length must not exceed 3m (9.8 ft.). When a monitor is connected to the SATATYA device, the default display resolution will be set at 1280X720 for NVRX series.</p> <p>The user can manually adjust the display resolution with the display options in SATATYA device. However, they are required to know the optimal resolution setting of the monitor to obtain the best display and picture quality. See "Using VGA and HDMI together" on page 46.</p>
Audio Out	Connect Audio Out Port to a speaker.
Audio In	Connect to a pre-amplified audio sources, such as a microphone. The RCA Connector Audio In 1&2 and 15 pin Audio In(1-8) are available.



1. When using the Relay outputs, ensure the voltage/current capacity of the relays are not exceeded.
2. For 15 pin connector, consider pin1 from the left side.

Using VGA and HDMI together

When SATATYA device is connected through VGA port then default resolution on local display is 1280x720.

Now when you connect monitor on the HDMI port of SATATYA device, then HDMI confirmation message will appear on the HDMI monitor asking for upgrading the resolution to 1920x1080.

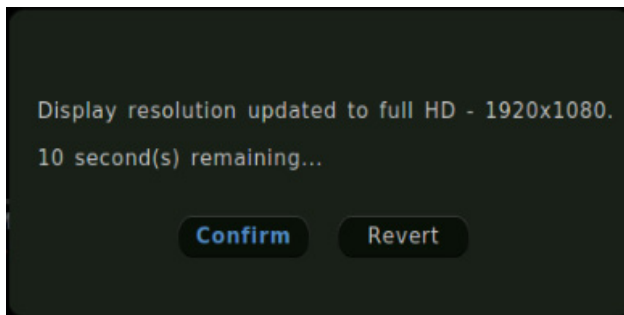

If **Confirm** button is clicked the resolution will get updated to 1920x1080 and the HDMI monitor will start displaying the view. With this VGA monitor will stop the display.

If **Revert** button is clicked then the resolution set before the HDMI detection will be applied.



NVRX/NVRX P2 Series variants can be connected through HDMI port only and default resolution on local display is 1920x1080.

USB Keyboard

For enhanced accessibility and faster navigation, various functions in the Local Client can be performed using keyboard shortcuts. A list of available shortcut keys with the action they perform, have been broadly classified as below.



The USB Keyboard and the shortcuts are supported with the NVRX/NVRX P2 series variants only.

[“Shortcuts to use in Camera Layout page”](#)

[“Shortcuts to use within all the Configuration pages”](#)

[“General Keyboard functions”](#)

Shortcuts to use in Camera Layout page

Camera Layout Page

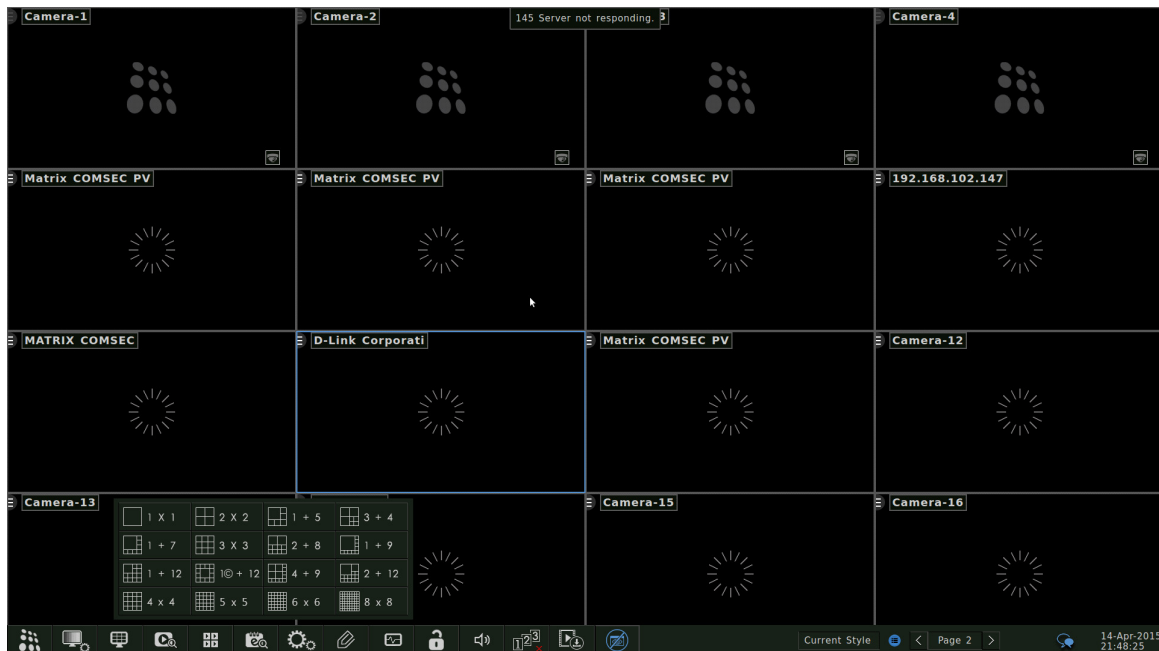

Purpose

Keys

To Show/Hide Navigation Panel	F4
To open Display Mode pop-up containing the various layout options	F1
To open Synchronous Playback window to view playback of selected cameras	F2
To Start/Stop Recording for the selected camera from the Camera Layout	F3
To Turn ON/OFF Instant Playback for the selected camera	F6
To take Snapshot of the selected camera	F7
To Turn On/Off Auto Page Navigation	F8
To change the layout of selected camera to 1x1	Enter/F11
To remove the selected camera from the Camera Live View Layout	Esc (2 times)
To Enable the Live-View tool-bar for selected camera	Insert

Shortcuts to use within all the Configuration pages



Purpose

Key

To shift the main control in forward direction	Tab
To shift the main control in reverse direction	Shift + Tab
To transfer the control from the main pages to the sub pages and vice-versa E.g. Refer snapshot above, navigating from 1 (main menu) to 2 (sub page) as shown in snapshot above.	Insert
To navigate through sub controls E.g. Navigating within the live view layout	Arrow Keys (Up, Down, Left and Right)
To select an option from the drop-down list	Enter > Up/Down Keys > Enter
To modify Time	Enter > Up/Down Keys > Enter
To enable the text box for modifications and save them	Press Enter key > Perform required changes > press Enter key again > Ctrl + S
To select and toggle radio button	Tab > Enter
To access the picklist and select required option	Enter > Up/Down Keys > Enter
To enable/disable the checkbox state	Enter
To close the pop-up window and drop-down	Esc (2 times)
To shift to next line in text box (like Message box)	Ctrl + Enter
To control seek bars or sliders	Enter > Left/Right Keys
To change the configurations to default values	Ctrl + D
To refresh the configurations	F5

General Keyboard functions

Purpose	Key
Select All	Ctrl + A
Cut	Ctrl + X
Copy	Ctrl + C
Paste	Ctrl + V
Undo	Ctrl + Z
Redo	Ctrl + Y

Virtual Keypad

The SATATYA device also provides a virtual keypad option to insert text into fields requiring alphanumeric strings. The virtual keypad pops up whenever the relevant field is selected as specified. The following keypad pops up as shown.

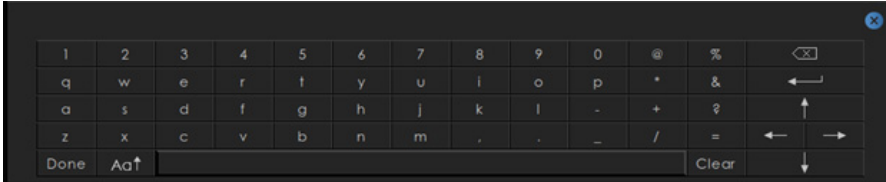

Use the direction arrow controls on the remote control to navigate through the characters on the virtual keypad. Press the **Enter** button to select the highlighted characters.

Use the **Shift** key to toggle between the uppercase and lowercase keypads as shown. By default, lowercase keypad will be displayed.

The **Clear** key enables the user to blank the input field and start afresh while the **backspace** key enables the user to clear field one character at a time.

Using the IR Remote Control

The SATATYA device can be locally configured using either of the following user interface options:

- IR Remote control
- Scroll Mouse

The SATATYA device can be configured or controlled with the IR remote control as shown in the following figure. Batteries (2x AAA) must be installed before operating.

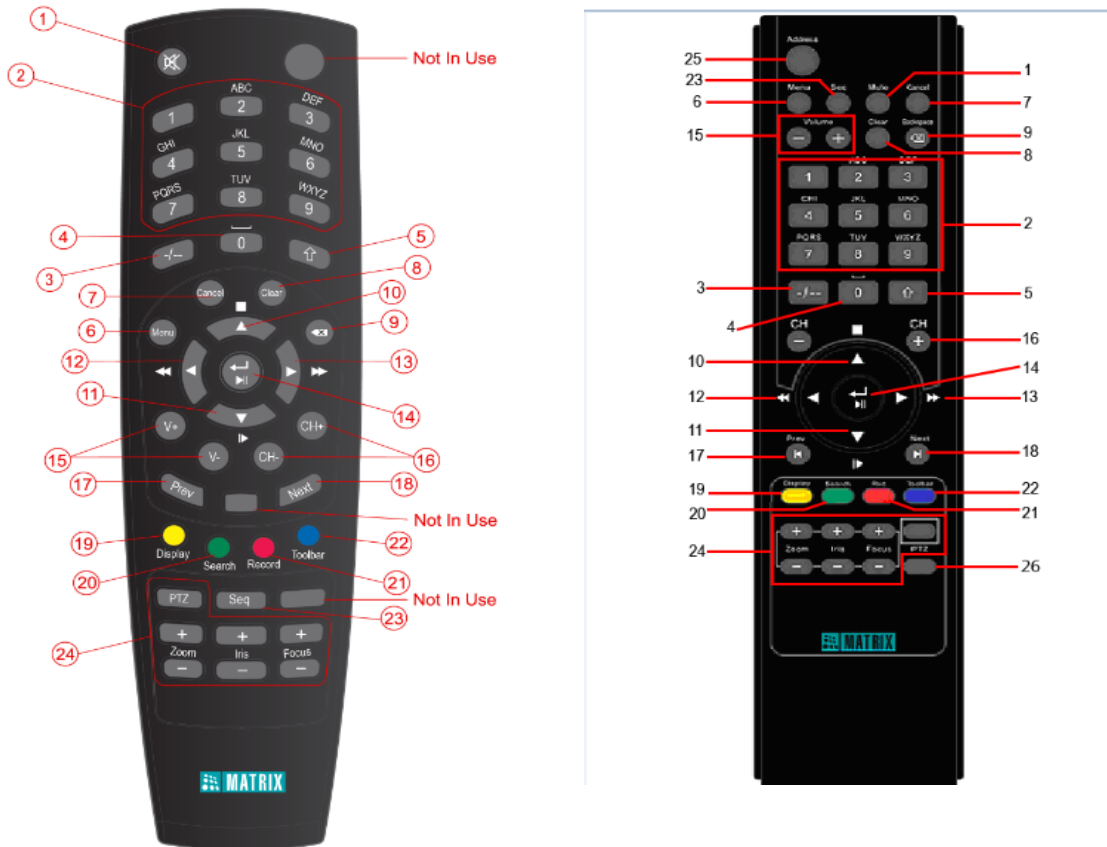

Sr. No.	Button Name	Function
1	Mute	To disable audio mode, toggles between the enable and disable audio.
2	Alphanumeric buttons	To enter password, channel or switch channel.
3	-/--	To change the single or two digit channel number.
4	0 and Spacebar	The '0' button loads the default layout, also used for creating space.
5	Shift Key ↑	No action in idle mode. To toggle between Uppercase and Lowercase characters on the virtual keyboard.
6	Menu	To load menu list (Substream, PTZ control, Start Recording, Snapshot, Zoom In, Start Audio) on the selected window in the Local view.

Sr. No.	Button Name	Function
7	Cancel	To highlight the Cancel button to exit an interface. To return from the full screen view of a particular channel to the selected layout.
8	Clear	To clear the selection.
9	Backspace	To edit text fields.
10	Up	To scroll through the various values available for each parameter of a functionality. To navigate through the virtual keyboard.
11	Down	To scroll through the various values available for each parameter of a functionality. To navigate through the virtual keyboard.
12	Left	To navigate options in a menu item. To navigate between the monitoring windows or set of channels when the default layout template is being loaded. To navigate through the virtual keyboard.
13	Right	To navigate options in a menu item. To navigate between the monitoring windows or set of channels when the default layout template is being loaded. To navigate through the virtual keyboard.
14	Enter	To enter menu, select the desired menu option. To select characters on the virtual keyboard, to store a setup value in the menu, or to display the 1 x 1 layout of the selected monitoring window.
15	Volume Control	To load the volume control interface for the audio option.
16	Channel Control	To load the next or previous channel or set of channels depending on the current layout.
17	Previous	To navigate to the previous frame, when the device is in playback mode.
18	Next	To navigate to the next frame, when the device is in playback mode.
19	Display	To select the Layout from the various layout templates of the device. This button is also mapped to the Default button on the configuration menu screens.
20	Search	To load the search interface to view recordings. This button is also mapped to the Refresh button on the configuration menu screens.
21	Record	To load the manual recording interface. This button is also mapped to the Save button on the configuration menu screens.
22	Toolbar	To load the tool bar. This button is also mapped to the Cancel button on the configuration menu screens.
23	Seq	To start auto sequencing of screen in full screen mode.
24	PTZ Controls	To adjust the iris, focus and zoom of the PTZ camera.
25	Address	Click on this key to input device serial number. Check the availability of this key in your Remote.
26	Blank	Press this button and any two number keys to give addressing to the Remote.

Powering the SATATYA device

The ampere ratings of adapter for the all the SATATYA devices has been classified in the following tables.

To Power on NVRX Variants	NVR0401XS P2/ NVR0801XS P2/ NVR1601XS P2	NVR0801X/ NVR1601X NVR0801X P2/ NVR1601X P2	NVR1602X/ NVR3202X NVR1602X P2/ NVR3202X P2	NVR3204X/ NVR6404X/ NVR3204X P2/ NVR6404X P2	NVR6408X/ NVR6408X P2/ NVR9608X P2
Power Supply	12VDC, 2A	12VDC, 5A	12VDC, 5A	AC supply	AC supply

To Power on other NVR Variants	NVR8S	NVR16S	NVR 24P	NVR16H	NVR64P/S
Power Supply	12VDC, 2A	12VDC, 5A	12VDC, 5A	12VDC, 7A	AC supply

To Power on HVR Variants	HVR1624P	HVR1624S	HVR0824P	HVR0824S	HVR0408P	HVR0408S
Power Supply	12VDC, 7A	12VDC, 5A	12VDC, (7A	12VDC, 5A)	12VDC, 2A	12VDC, 2A

When the power jack is connected to the device, the power LED illuminates. In the event of disconnecting the power jack of the adapter, the LED gets off.

After completing all the necessary steps, you can power up the device.

The SATATYA device is also equipped with a Real Time Clock with on board Battery backup.

- The battery in HVR is a 3VDC/ 220 mAh (Li/MnO₂) Lithium or Manganese Dioxide Coin Battery (CR 2032-Non Rechargeable). The diameter is 20mm and height is 3.2mm.
- The battery in NVR24P is a 3VDC/ 18 mAh (Li-Al) alloy-Manganese Dioxide Coin Battery (ML 1220-Rechargeable). The diameter is 12.5mm and height is 2.0mm.
- The battery in NVR8S is a 3VDC/ 220 mAh (Li/MnO₂) Lithium or Manganese Dioxide Lithium Battery (CR 2032-Non Rechargeable). The diameter is 20mm and height is 3.2mm.
- The battery in NVRX/NVRX P2 is 3VDC/ 11 mAh (Li) Lithium Coin rechargeable battery. The diameter is 9.5mm and height is 2.1mm.



The battery is located on the device board and should be replaced only by authorized service personnel.

Power supply for the system must be separate from other heavy electrical loads like air-conditioners, heaters, welding machines, electrical motors, etc.

Power up sequence

On powering up the device, the Power LED is illuminated. The system goes through the booting process and on completion, runs an LED test of all the LEDs on the Front panel. The system then emits a long beep to indicate the completion of the initialization process.



It is highly recommended that the SATATYA device be connected to an Uninterruptible Power Supply (UPS). This provides temporary backup power to operate the unit during a limited power outage. The UPS also protects the unit from AC power fluctuations and power spikes.

Power should only be applied to the unit when all connections are completed and tested.



When the system is running you may feel the surface of the NVRXS P2 enclosure is hot. This is normal as the heat generated by HDD (Hard Disk) and electronic components is dissipated on the NVRXS enclosure body. Be careful when you come in contact the surface of the NVRXS enclosure.

Cabinet Mounting

The SATATYA device can be rack mounted using the side brackets, can be installed on a desktop or table or can be wall mounted. In the event of installing it on a rack mount, the device uses the four mounting screws (provided) or other appropriate fasteners. The different mountings supported by SATATYA devices are specified below.

NVRX Cabinet Mounting

Cabinet Mounting	NVR0401XS P2 / NVR0801XS P2 / NVR1601XS P2	NVR0801X/ NVR1601X NVR0801X P2/ NVR1601X P2	NVR1602X/ NVR3202X/ NVR1602X P2/ NVR3202X P2	NVR3204X/ NVR6404X/ NVR3204X P2/ NVR6404X P2	NVR6408X/ NVR6408X P2/ NVR9608X P2
Type of Mounting supported	Table/Desktop	Table/Rack	Table/Rack	Rack	Rack

NVR Cabinet Mounting

Cabinet Mounting	NVR8S	NVR16S	NVR24P	NVR16H	NVR64P/S
Type of Mounting supported	Wall Mount	Table/Desktop	Rack	Rack	Rack

HVR Cabinet Mounting

Cabinet Mounting	HVR1624P	HVR1624S	HVR0824P	HVR0824S	HVR0408P	HVR0408S
Type of Mounting supported	Rack	Table/ Desktop	Rack	Table/ Desktop	Wall Mount	Wall Mount

SATATYA Devices Dimensions

This section includes figures which show the different views of the SATATYA Devices cabinet to indicate the dimensions. All dimensions are given in mm.

Click on the following links to know NVR and HVR dimensions respectively.

[“SATATYA NVRX Variants Dimensions”](#)

[“SATATYA NVR Other Variants Dimensions”](#)

[“SATATYA HVR Variants Dimensions”](#)

SATATYA NVRX Variants Dimensions

NVR0401XS P2/NVR0801XS P2/NVR1601XS P2

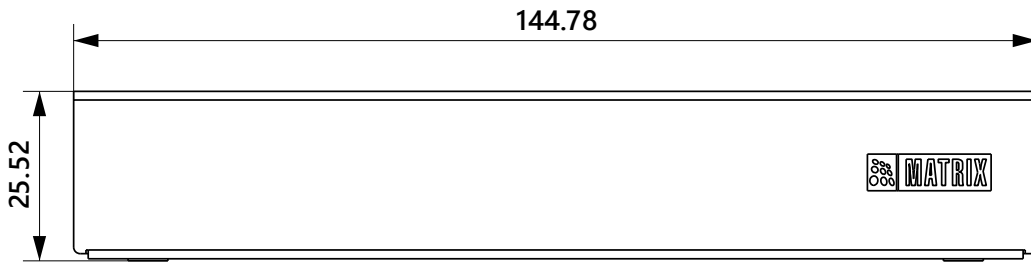

FRONT VIEW

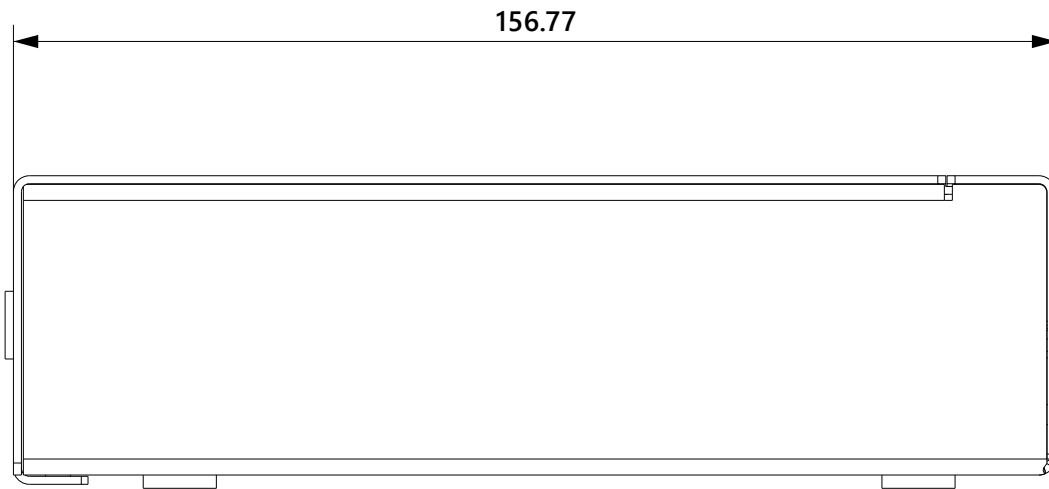

SIDE VIEW

NVR0801X/NVR1601X/NVR0801X P2/NVR1601X P2

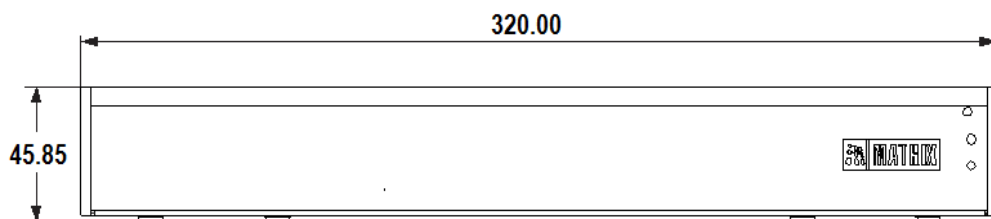

FRONT VIEW

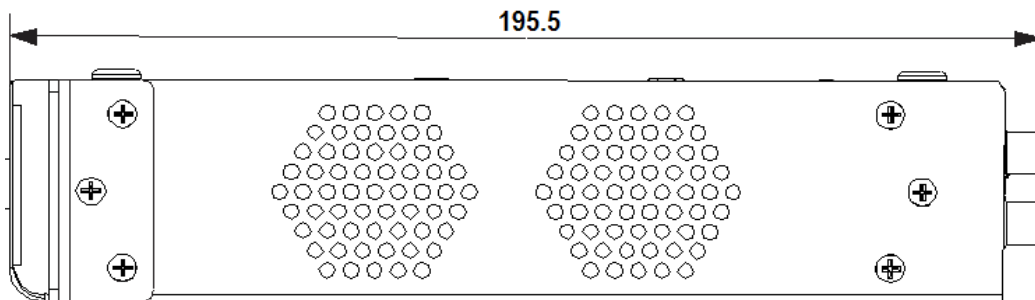

SIDE VIEW

NVR1602X/NVR3202X/NVR1602X P2/NVR3202X P2

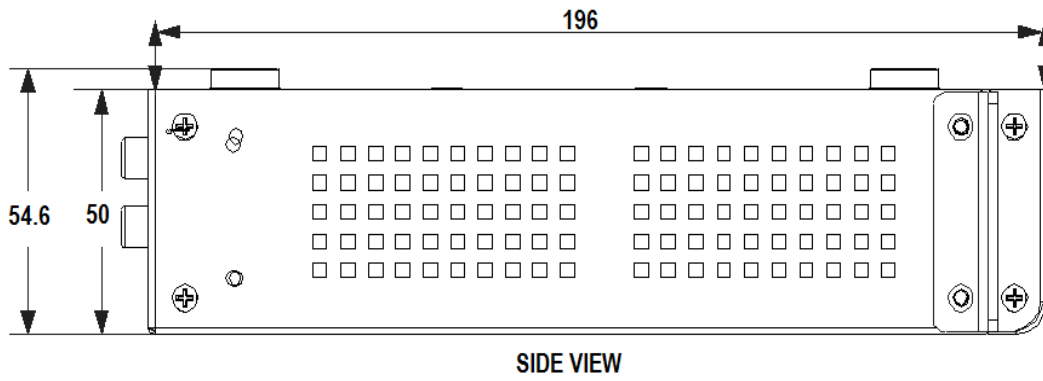
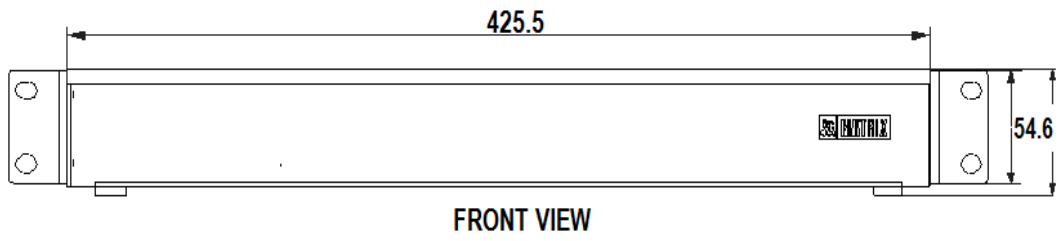

NVR3204X/NVR6404X/NVR3204X P2/NVR6404X P2

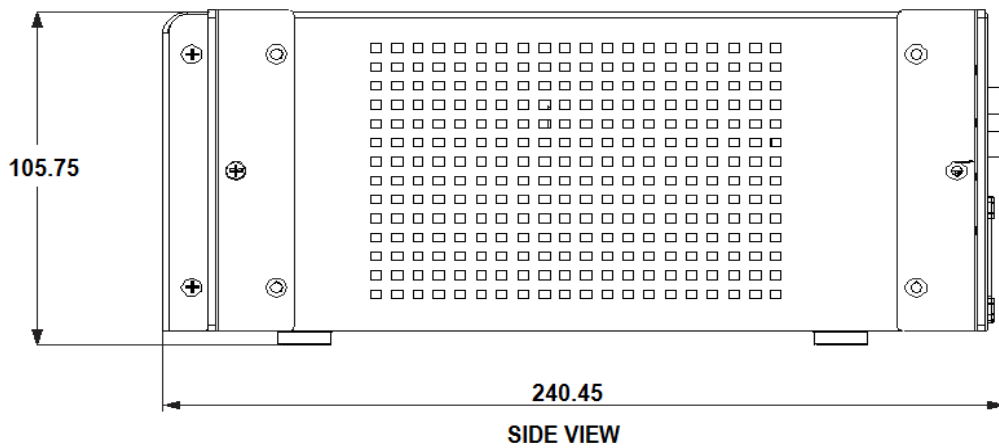
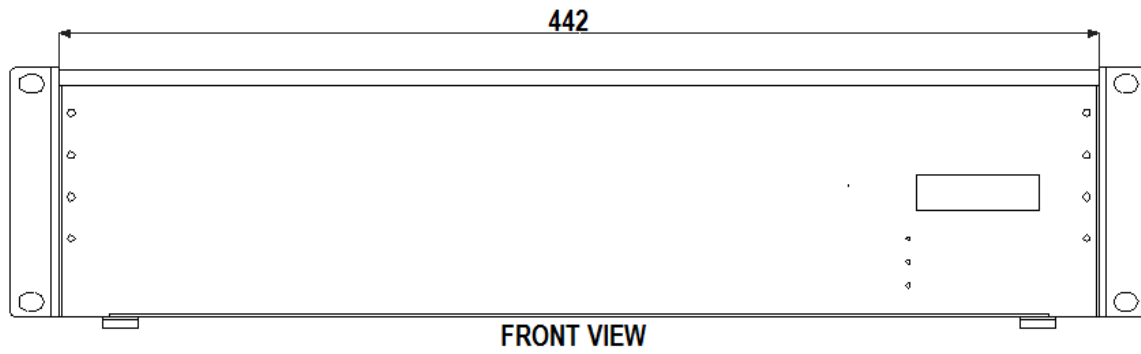

NVR6408X/ NVR6408X P2/NVR9608X P2

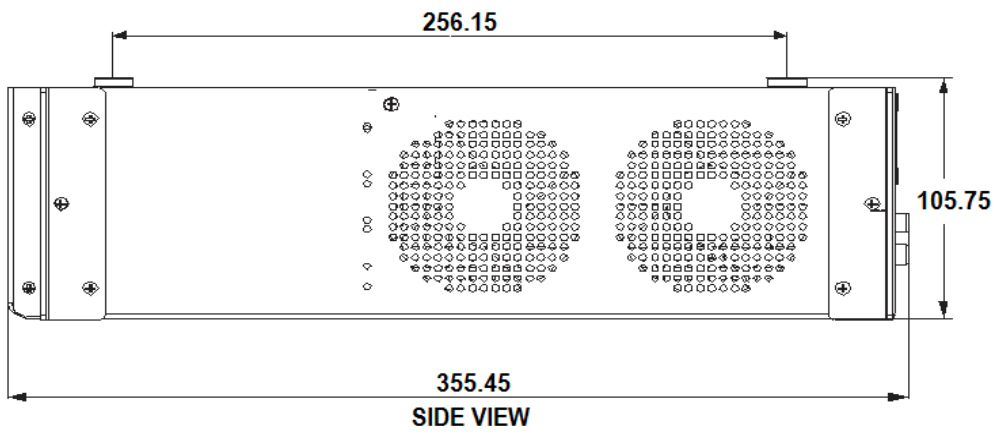
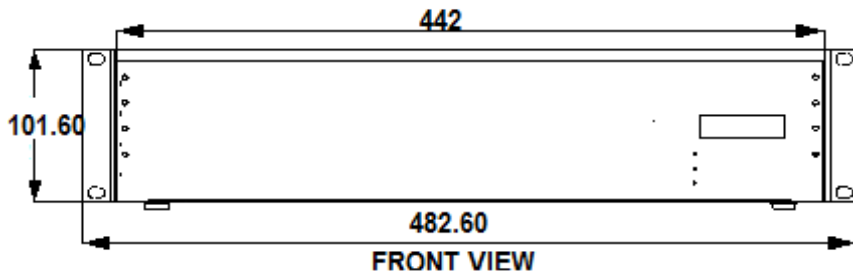

SATATYA NVR Other Variants Dimensions

NVR8S

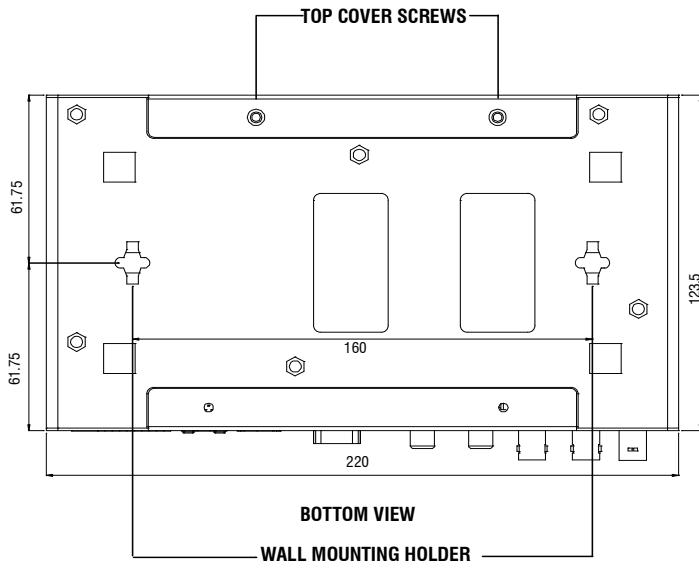

NVR16S

For Table Top

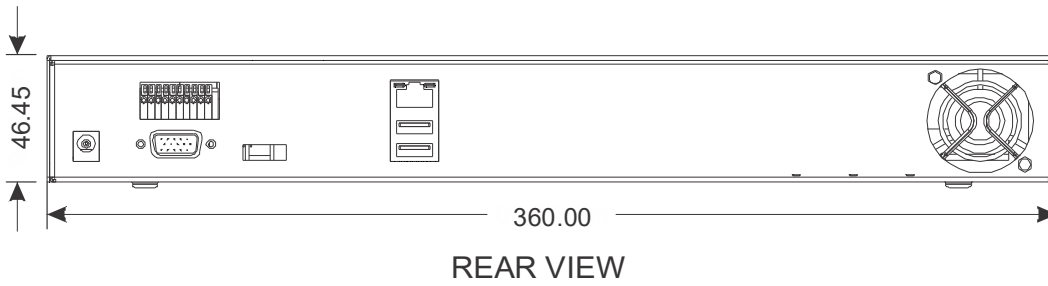

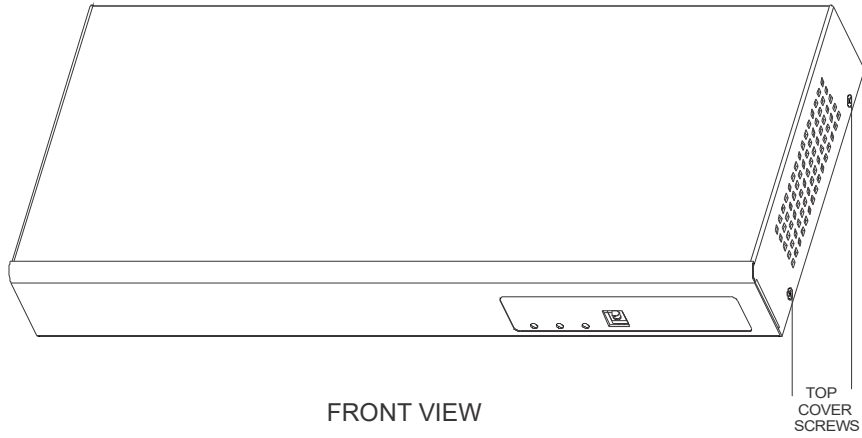

FRONT VIEW

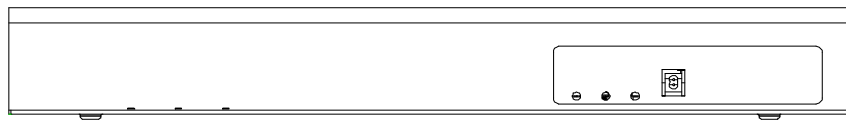

FRONT VIEW

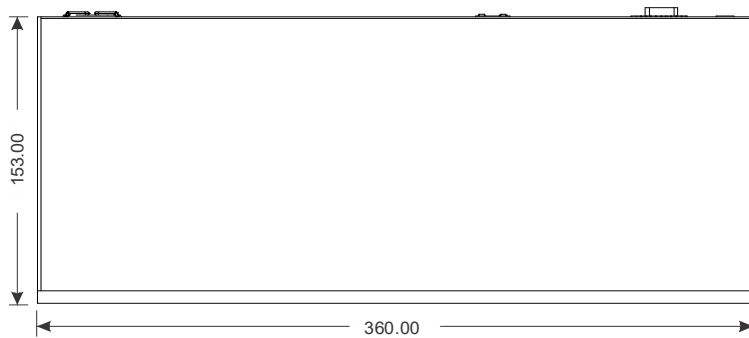

TOP VIEW

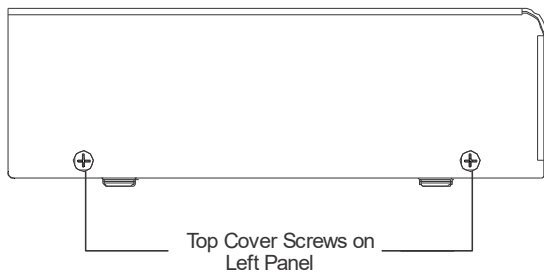

LEFT VIEW

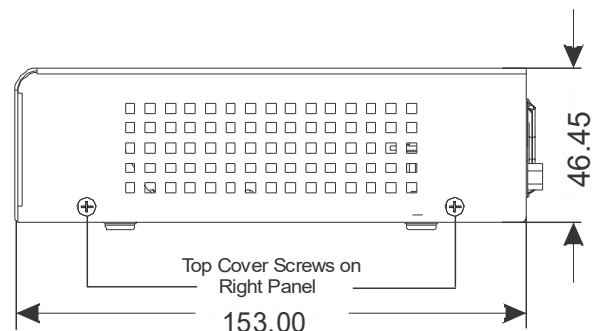

RIGHT VIEW

NVR24P

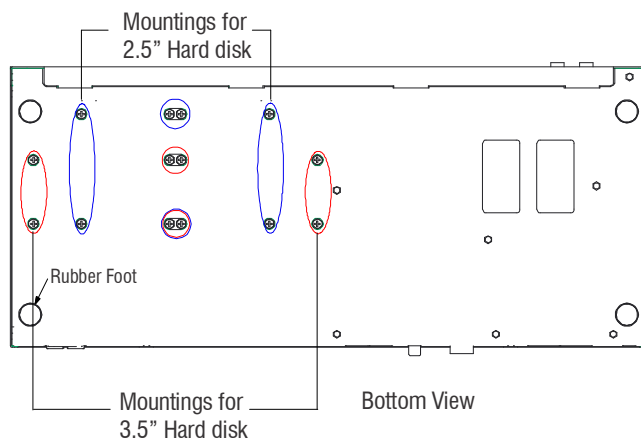
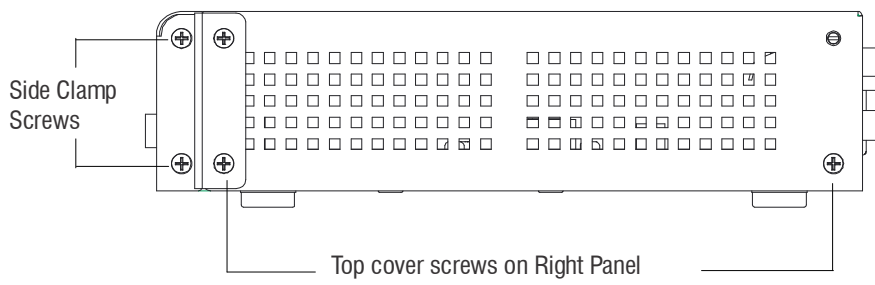
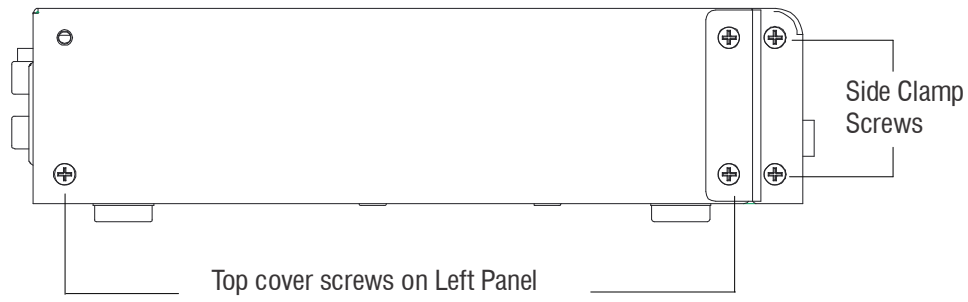

NVR16H

For Rack Mounting

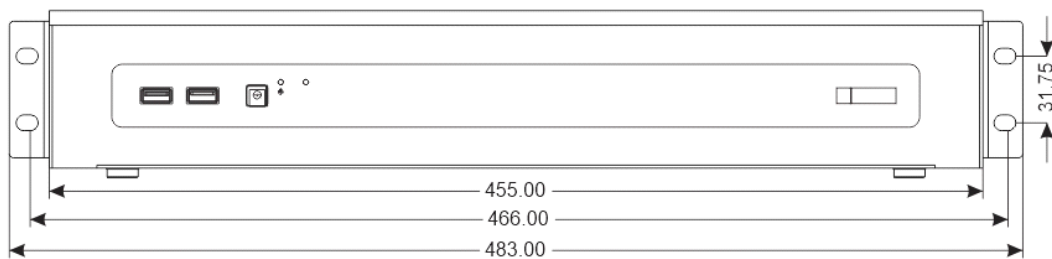

FRONT VIEW

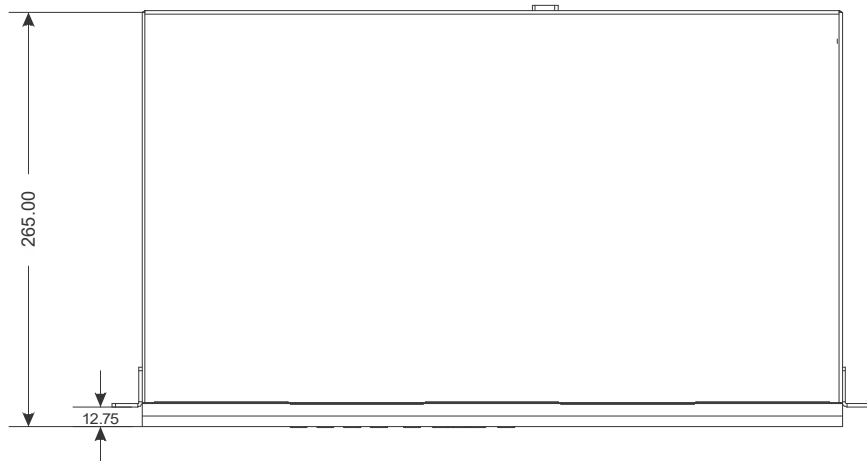

TOP VIEW

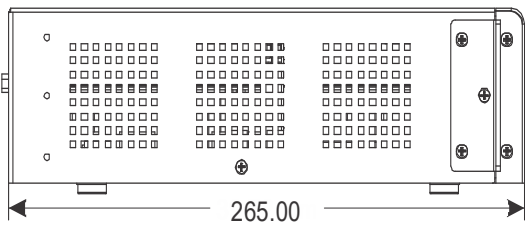

LEFT VIEW

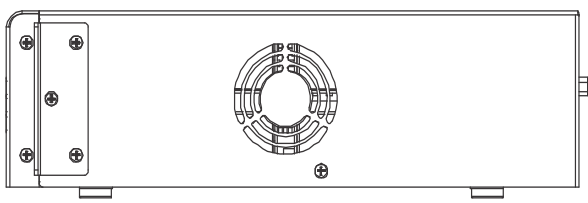

RIGHT VIEW

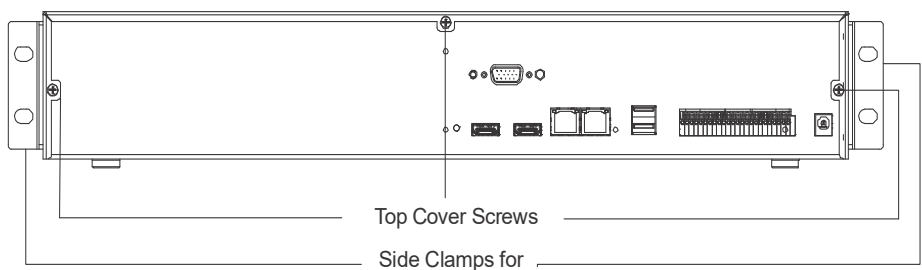

REAR VIEW

NVR64 P/S

Top View

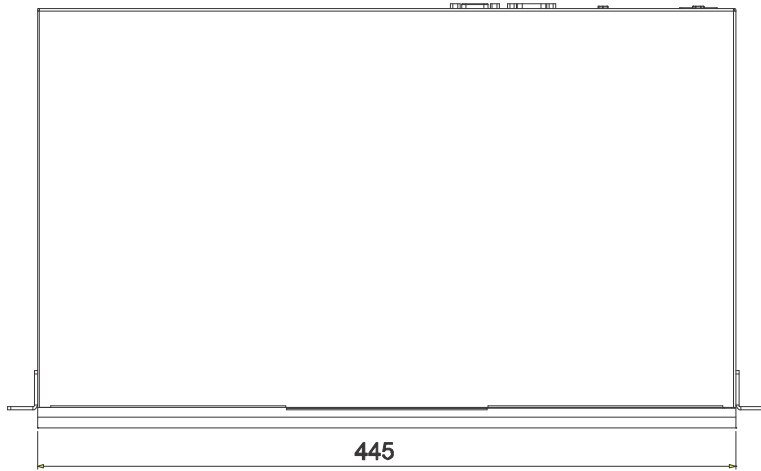

Front View

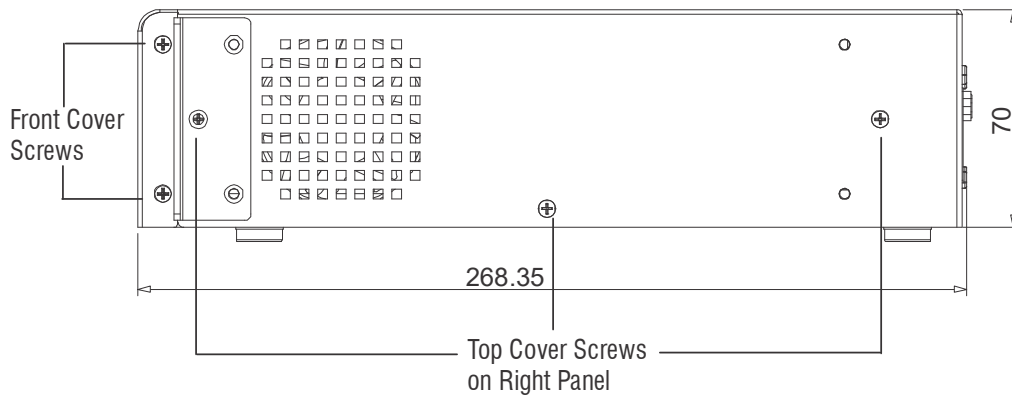
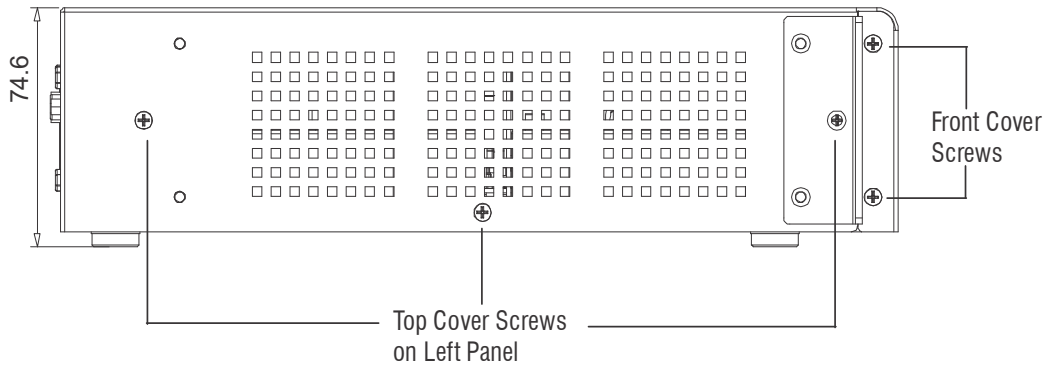
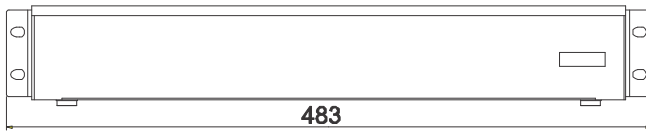

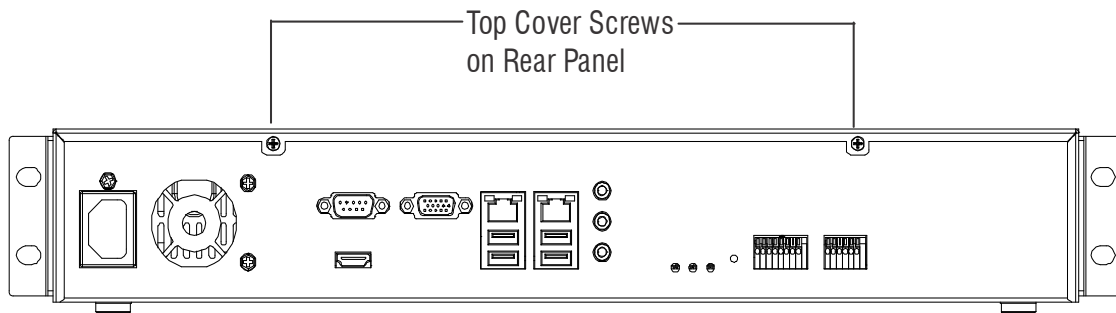

General layout of the NVR enclosure:

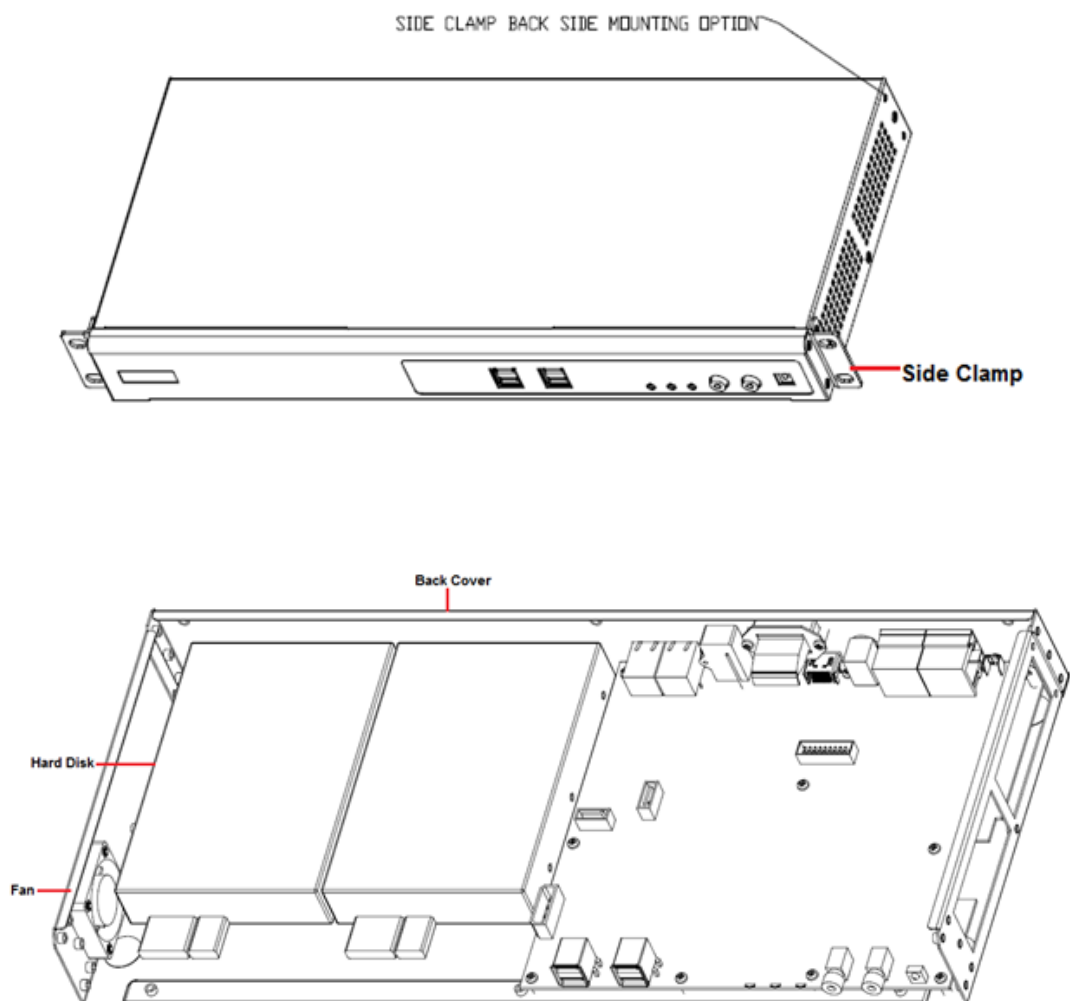

SATATYA HVR Variants Dimensions

HVR 16/8P

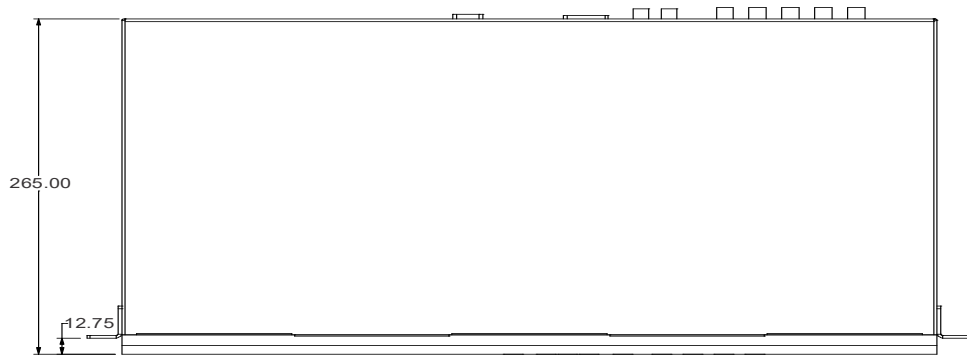

TOP VIEW

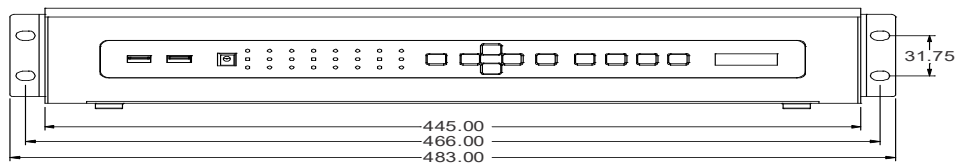

FRONT VIEW

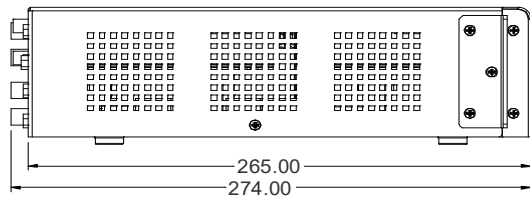

LEFT VIEW

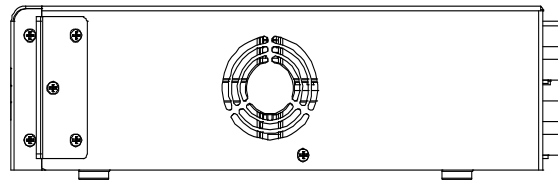

RIGHT VIEW

General layout of the HVR 16/8P

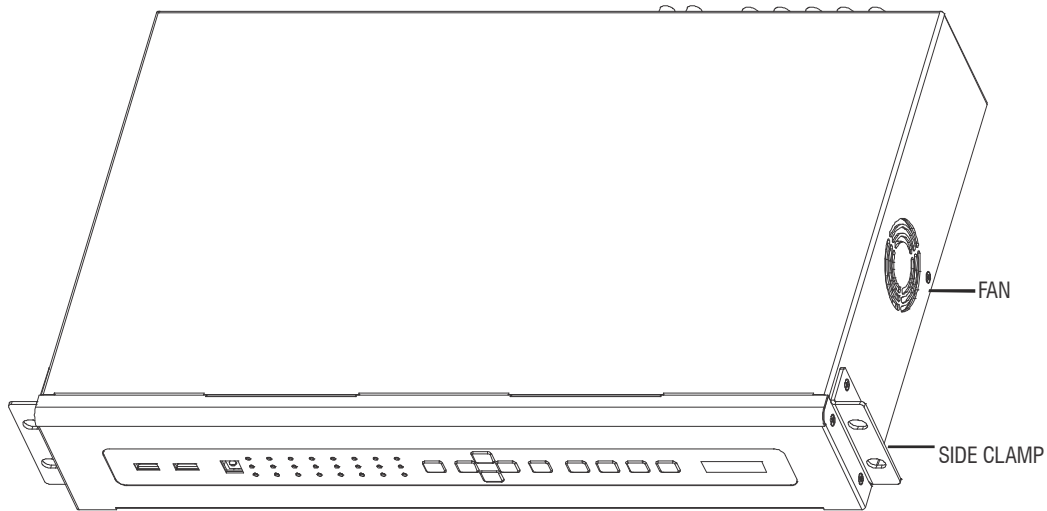

FRONT VIEW

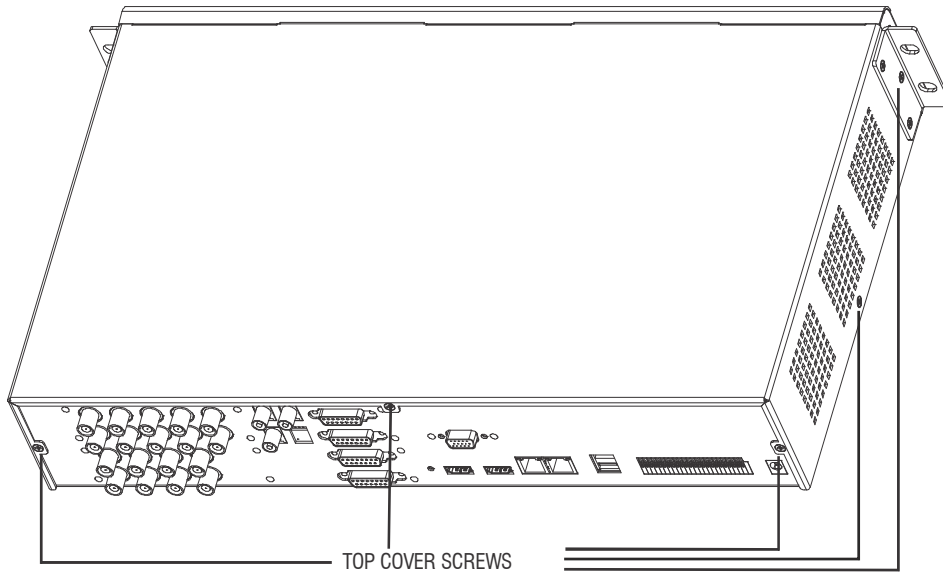

TOP COVER SCREWS

REAR VIEW

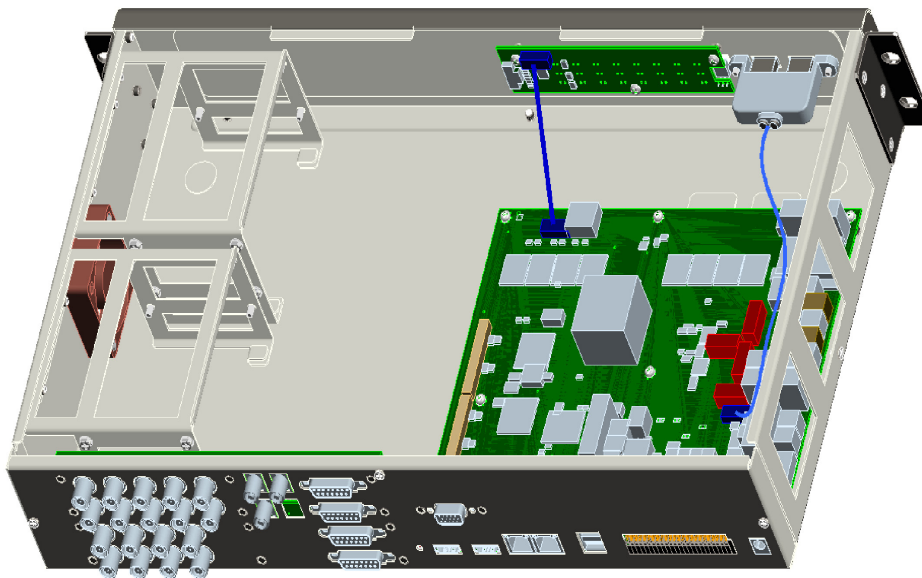

HVR 16/8S

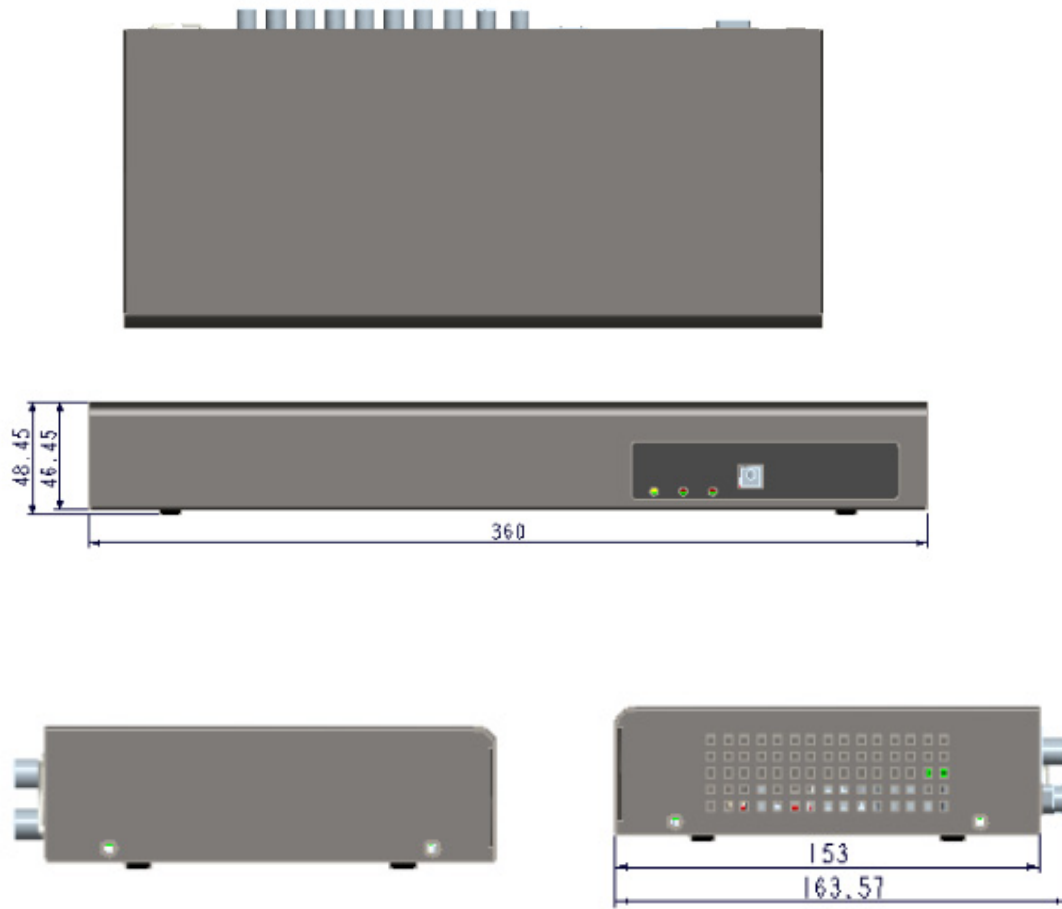

General layout of the HVR16/8S

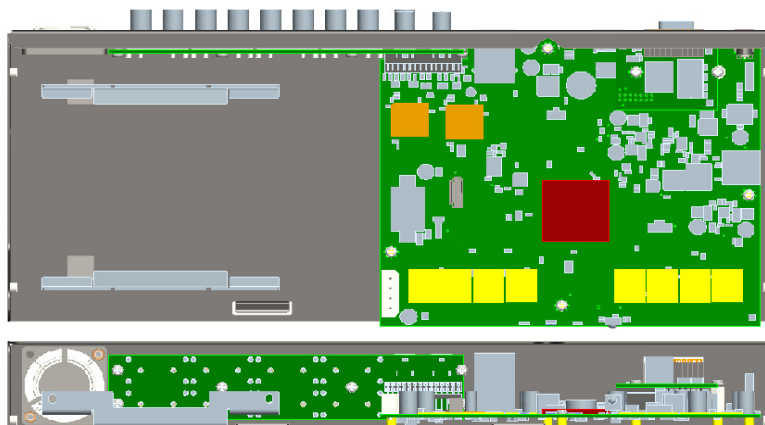



Front View

HVR4

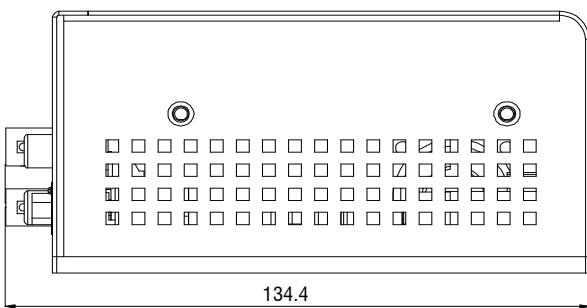

LEFT SIDE VIEW

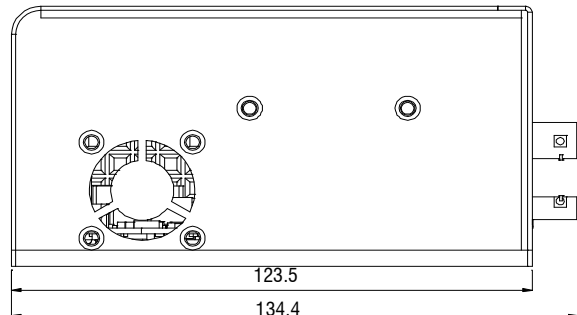

RIGHT SIDE VIEW

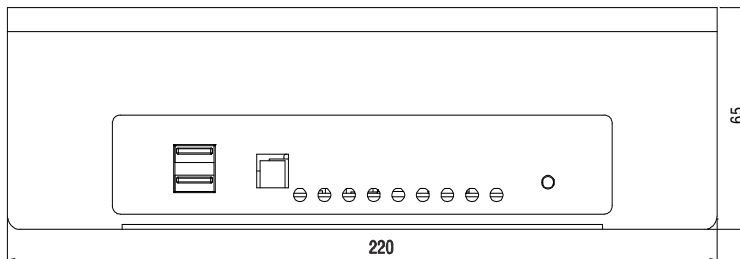

FRONT VIEW

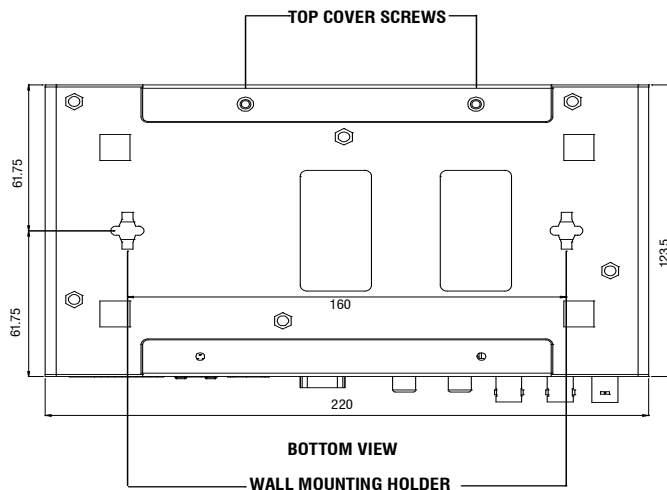

BOTTOM VIEW

WALL MOUNTING HOLDER

General layout of the HVR 4 Channel

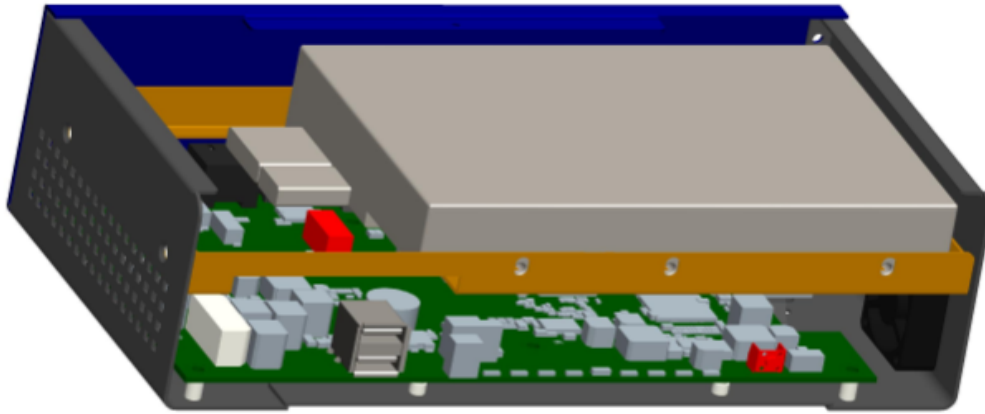

Installing Hard Disks

The Matrix SATATYA device can be fitted with various brands of commercially available SATA hard disks. The number of **hard disks** that can be installed in SATATYA devices is shown below. Each hard disk can support upto **10TB** (TeraBytes) of storage capacity.

NVRX Series Variants HDD support

HDD	NVR0401XS P2 / NVR0801XS P2 /NVR1601XS P2	NVR0801X/ NVR1601X NVR0801X P2/ NVR1601X P2	NVR1602X/ NVR3202X/ NVR1602X P2/ NVR3202X P2	NVR3204X/ NVR6404X/ NVR3204X P2/ NVR6404X P2	NVR6408X/ NVR6408X P2/ NVR9608X P2
Max No. of HDD supported	1	1	2	4	8

Other NVR Variants HDD support

HDD	NVR8S	NVR16S	NVR24P	NVR16H	NVR64P/S
Max No. of HDD supported	1	1	2	4	4

HVR Variants HDD support

HDD	HVR1624P	HVR 1624S	HVR0824P	HVR0824S	HVR0408P	HVR0408S
Max No. of HDD supported	4	1	4	1	1	1

You are recommended to install video surveillance SATA Hard disks of any standard brand.



CAUTION! Any electrostatic energy coming in contact with the hard disk or the internal parts of the NVR can cause permanent damage to them. Before you begin the installation of the hard disk, make sure your workstation is static-free. Always wear an electrostatic discharge preventive wrist strap or belt and use a grounding mat.

Make sure power supply is disconnected. Unplug the power adapter, if you have connected it to SATATYA NVRX/ NVRX P2.

Click on the following links to know the HDD installation of SATATYA NVR and HVR.

[“Installing HDD in NVRXS P2 Variants”](#)

[“Installing HDD in NVRX/NVRX P2 Variants”](#)

[“Installing HDD in other NVR Variants”](#)

[“Installing HDD in HVR Variants”](#)

Installing HDD in NVRXS P2 Variants

This section includes the common procedure of installing single Hard Disk in all the variants — NVR0401XS P2, NVR0801XS P2, NVR1601XS P2.

Hard Disk Mounting

1. Unscrew three screws at the bottom on the enclosure.

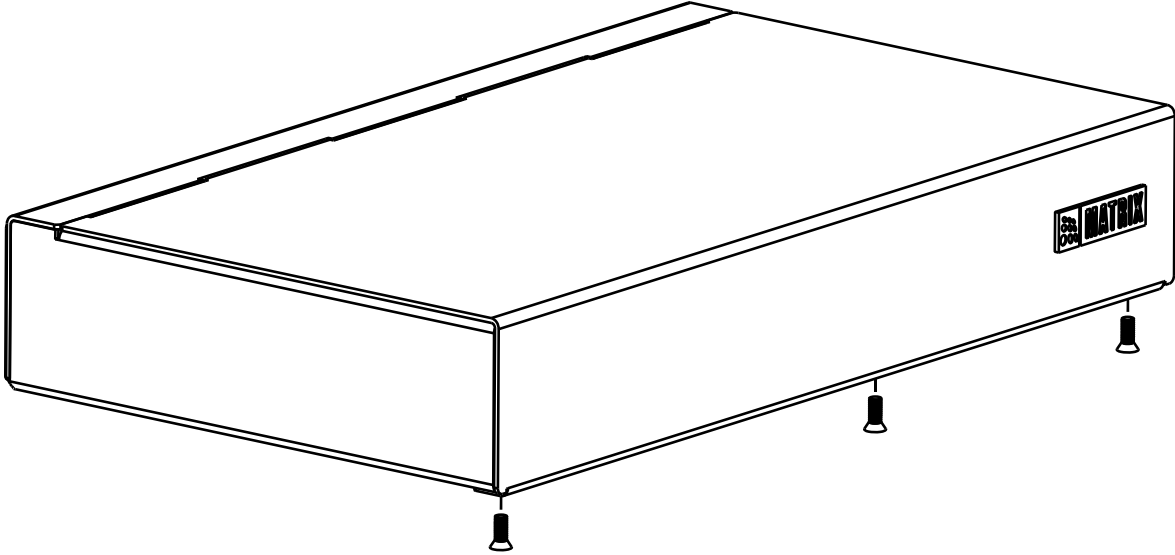

2. Slide the top cover backwards to remove.

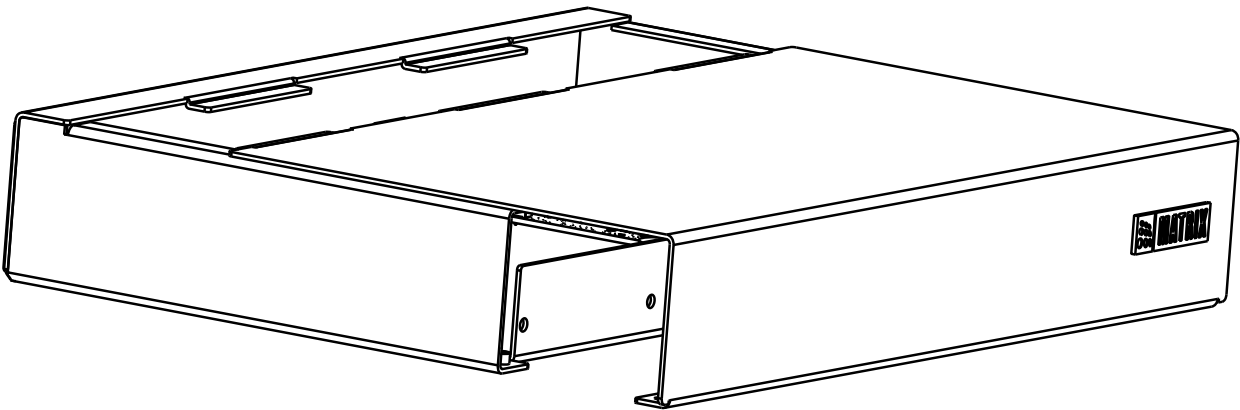

3. Place the HDD onto the HDD Stand-up.

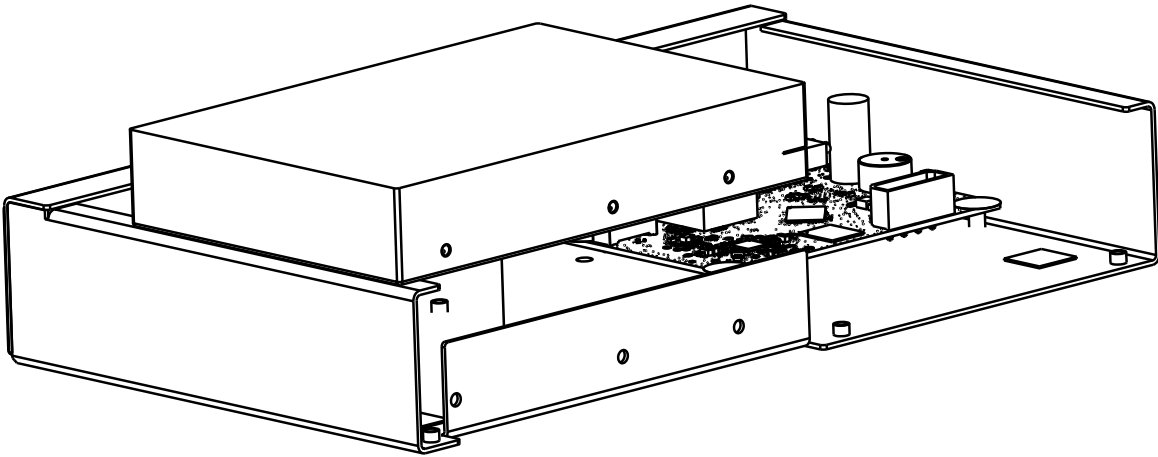

4. Align the holes of the HDD with that of the enclosure.

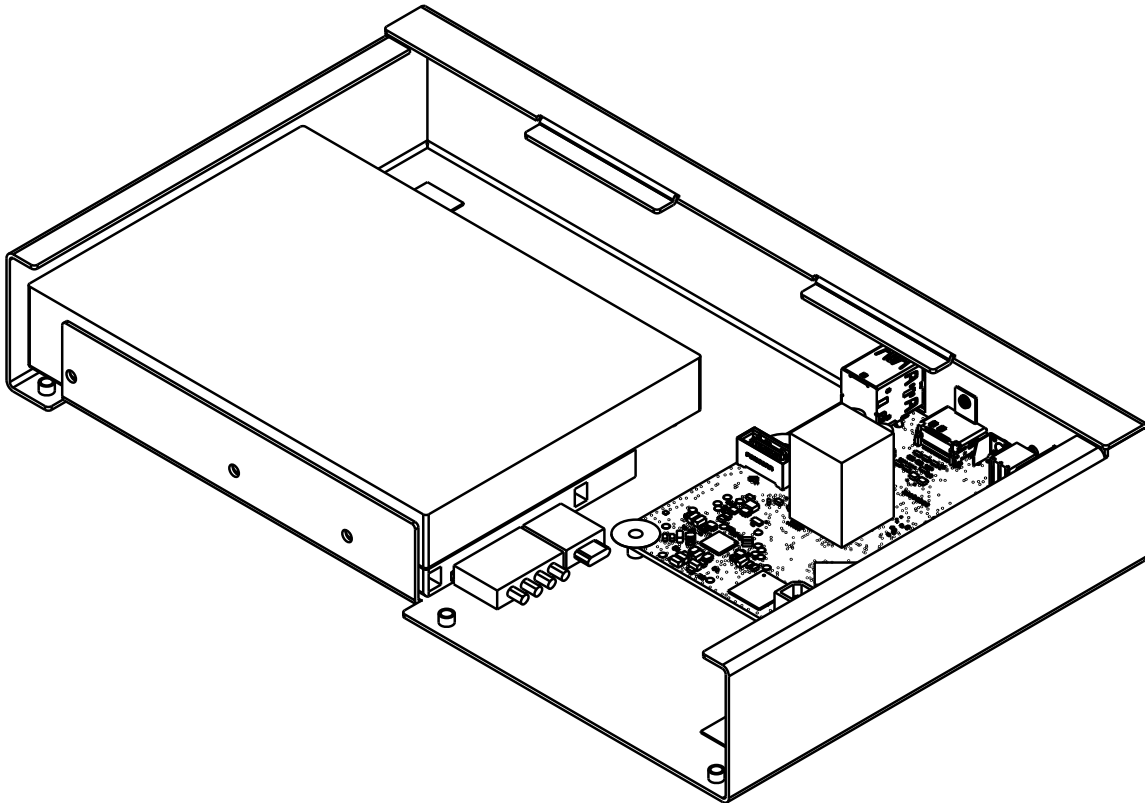

- Affix the three screws provided into the aligned holes and tighten the same.

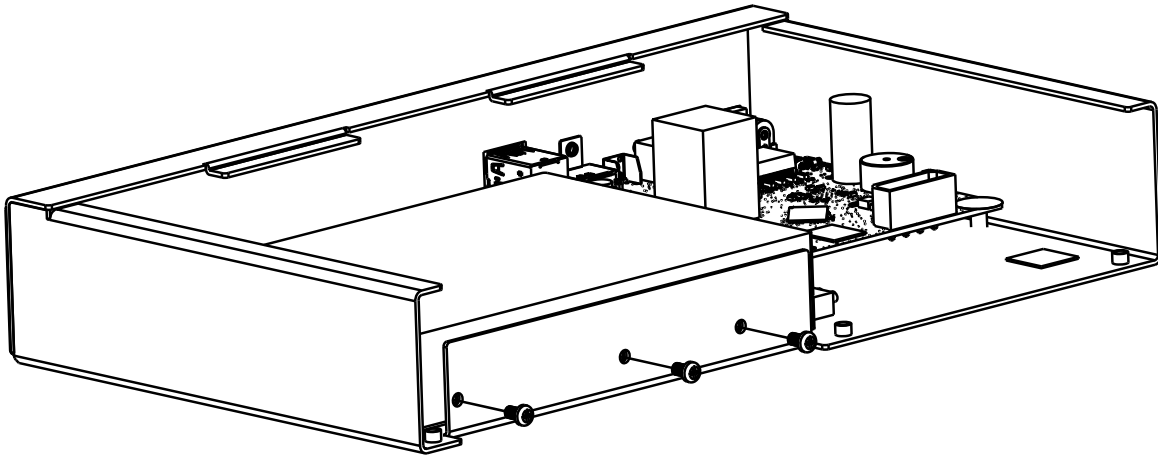

Hard Disk Cable Routing

- Inside the package you will find one SATA cable for the hard disk and one Power cable.
- Plug one end of the SATA cable(01) and Power cable (01) into the respective connectors on the hard disk and the other ends (02) of the cable as shown below.

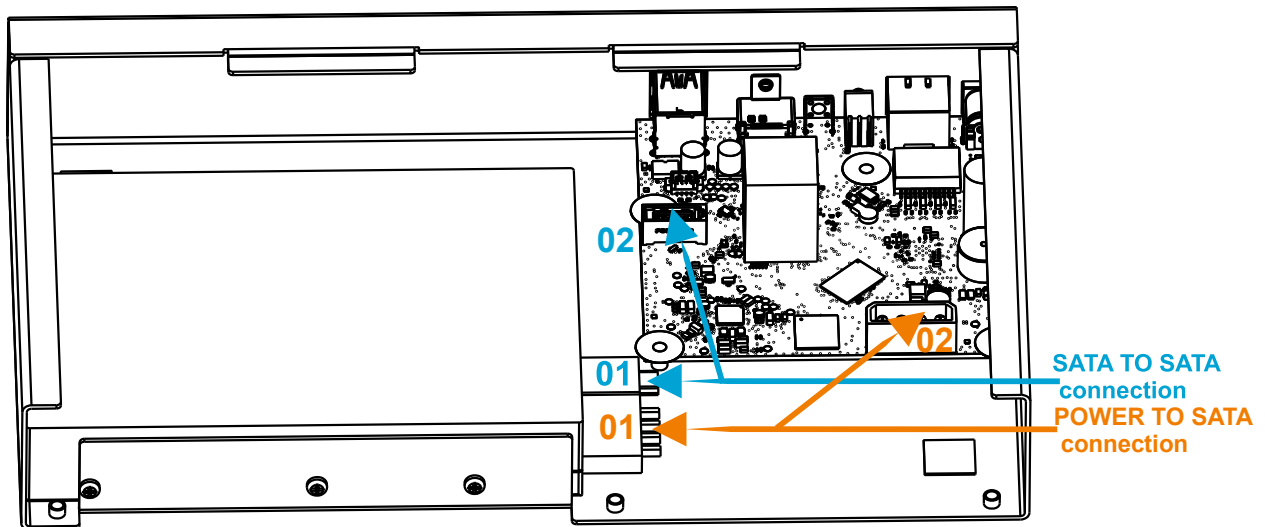

- Slide the top cover back in place and affix the three screws at the bottom of the enclosure.

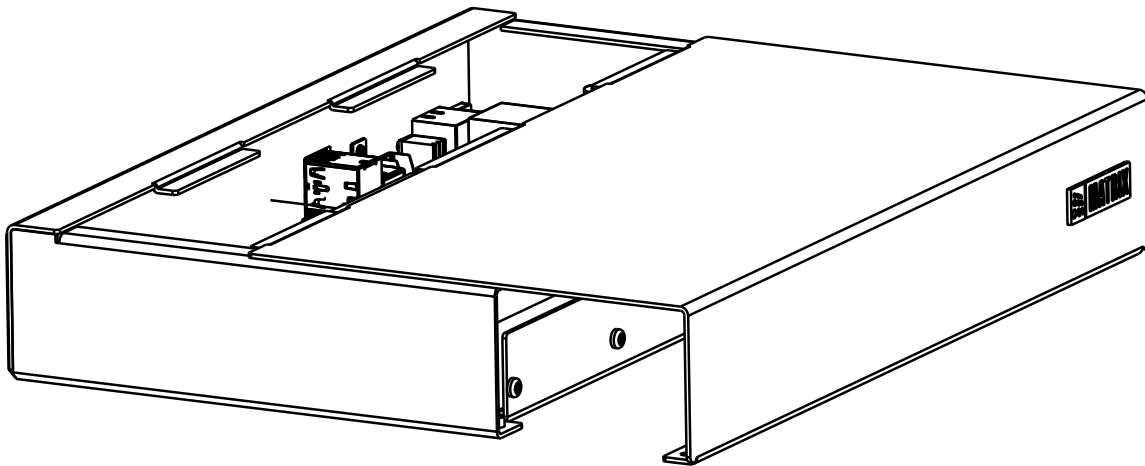

Installing HDD in NVRX/NVRX P2 Variants

NVRX/NVRX P2 series supports maximum eight Hard disks. The storage capacity of each hard disk is upto 10 Terabytes.

NVR0801X/NVR1601X/ NVR0801X P2/NVR1601X P2 and NVR1602X/NVR3202X/NVR1602X P2/NVR3202X P2 HDD Installation.

This section includes the common procedure of installing single Hard Disk in NVR0801X/NVR0801X P2, NVR1601X/NVR1601X P2, NVR1602X/NVR1602X P2 and NVR3202X/NVR3202X P2 variants.

Hard Disk Mounting

- Loosen the screws at the side panel to remove the top cover.
- Fix four screws in the HDD (Do not fit the screws completely, turn just three rounds).

NVR0801X/NVR1601X/NVR0801X P2/NVR1601X P2

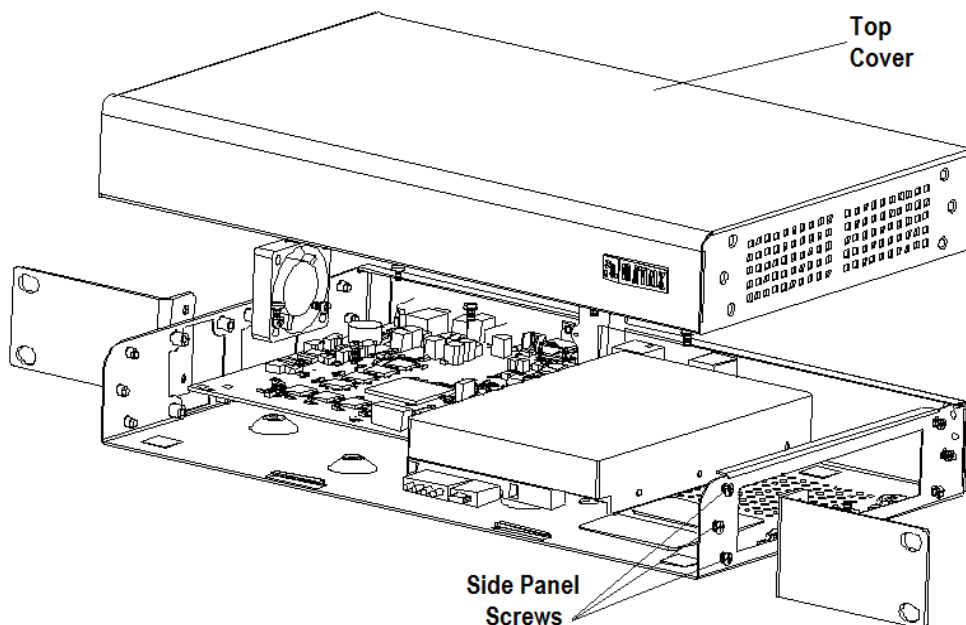

- Place the HDD in accordance with the four holes in the bottom of the enclosure as shown.

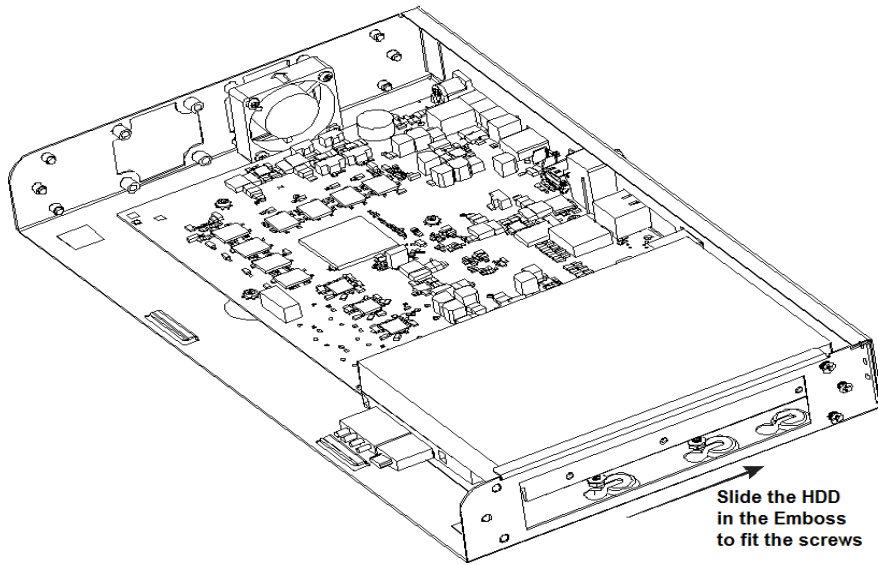

4. Slide the HDD along with the screw in the emboss.
5. Turn the device upside down and then turn the screw using a magnetic screw driver to fix the HDD firmly as shown below.

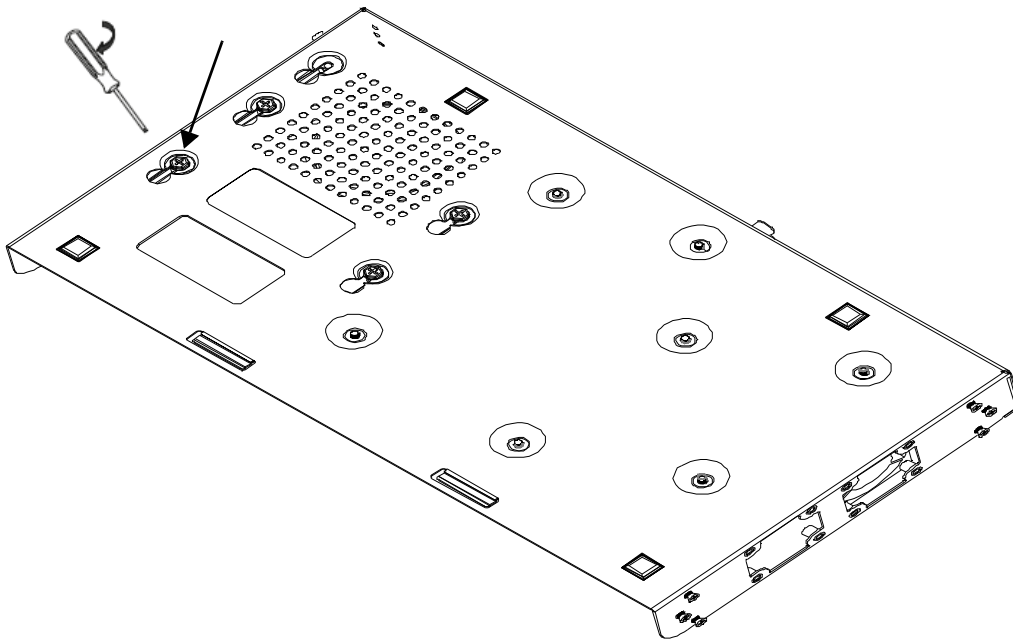

Maximum torque to be applied for tightening the screws is 3 kgf.cm. Applying more than specified torque will cause a damage to the HDD and the emboss.

Follow the same procedure for mounting two HDDS in NVR1602X/NVR1602X P2 and NVR3202X/NVR3202X P2 as shown below.

NVR1602X/NVR1602X P2/NVR3202X

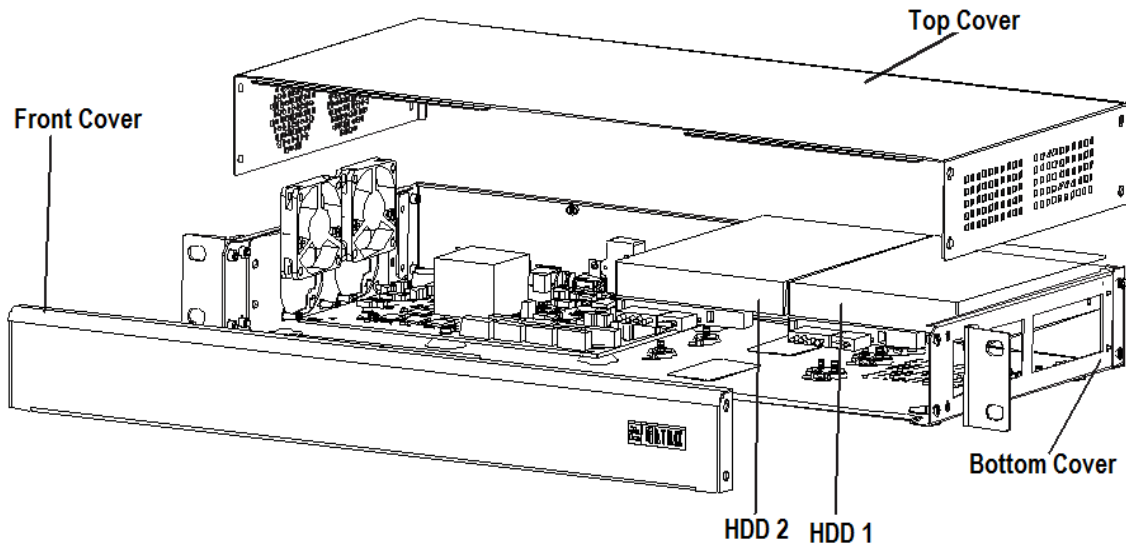

NVR3202X P2

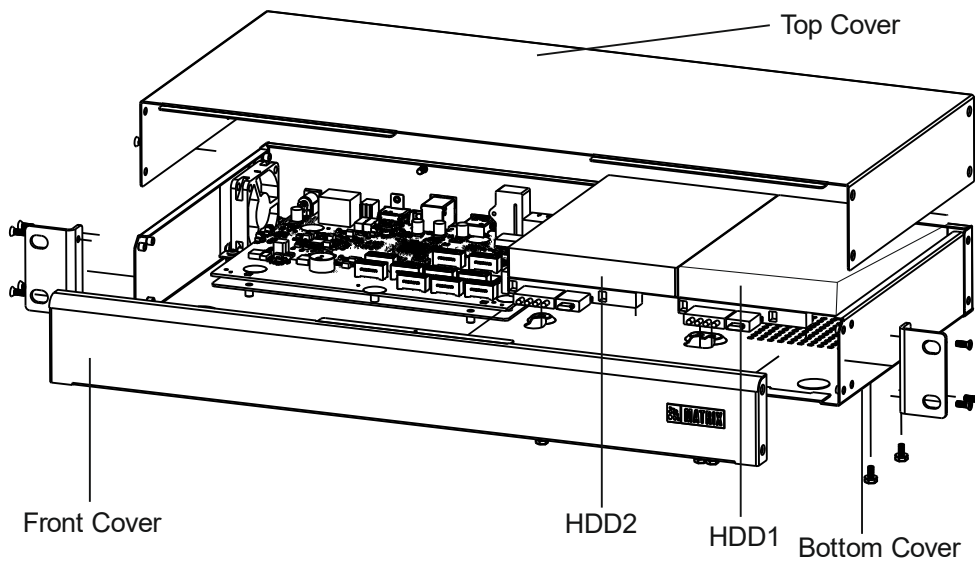

Hard Disk Cable Routing

1. Inside the package you will find one SATA cable in NVR0801X/NVR0801X P2 and NVR1601X/NVR1601X P2 and two in NVR1602X/NVR1602X P2 and NVR3202X/ NVR3202X P2 for each hard disk.
2. Plug the SATA cables and power cables into the respective connectors on the hard disk as shown below.

NVR0801X/NVR1601X/NVR0801X P2/NVR1601X P2

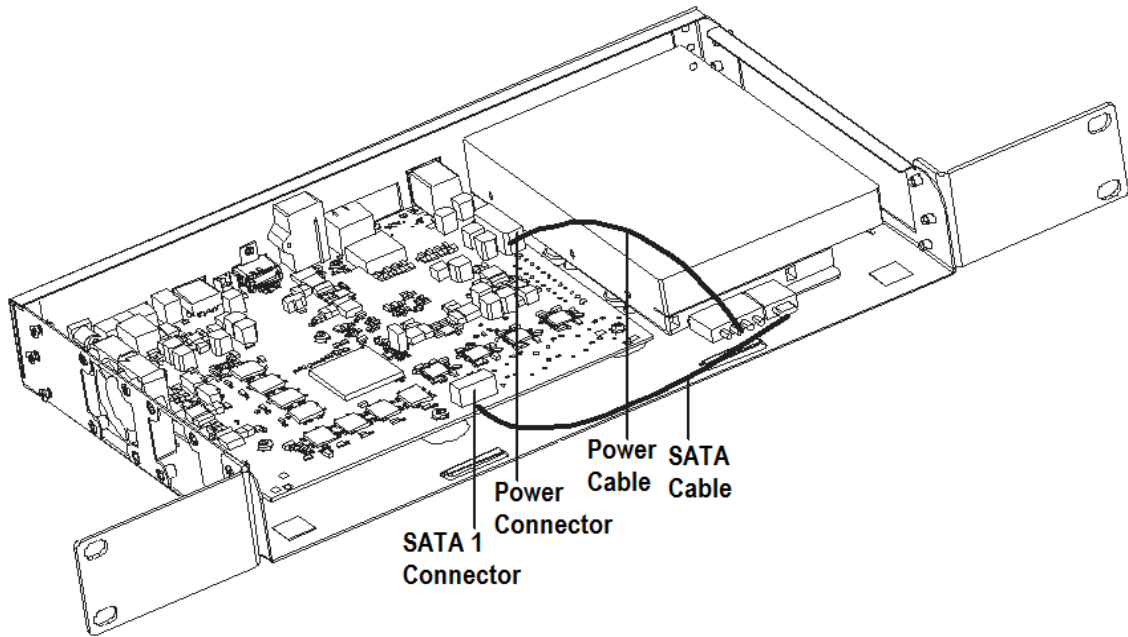

Similar connection can be done in **NVR1602X/NVR1602X P2/NVR3202X/NVR3202X P2**. Connectors are shown below.

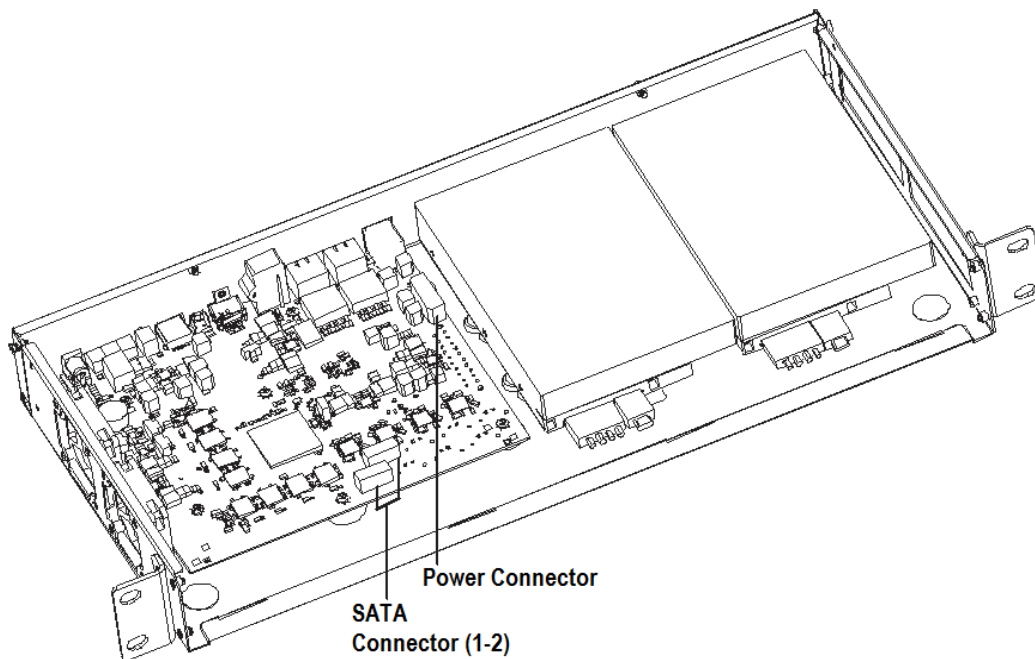

NVR3204X/NVR6404X/NVR3204X P2/NVR6404X P2 HDD Installation

Hard Disk Mounting

1. Loosen the screws at the side panel to remove the top cover.
2. Take the clamp and Place the Hard Disk inside the clamp. Secure the HDD inside the Clamp with the four screws provided using the magnetic screw driver.

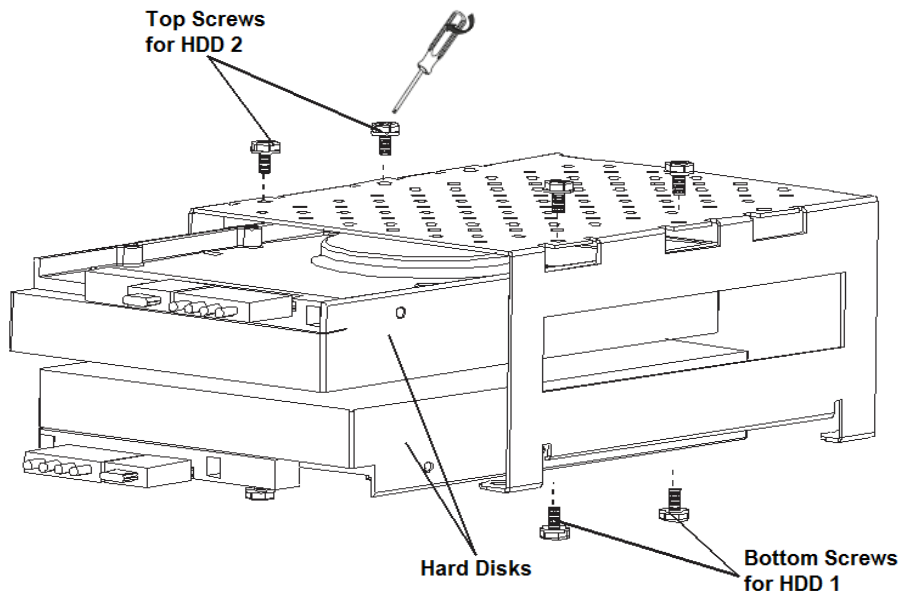

3. Now place the Clamp fitted with the Hard Disks on the bottom plate.

NVR3204X/NVR6404X/ NVR3204X P2/NVR6404X P2

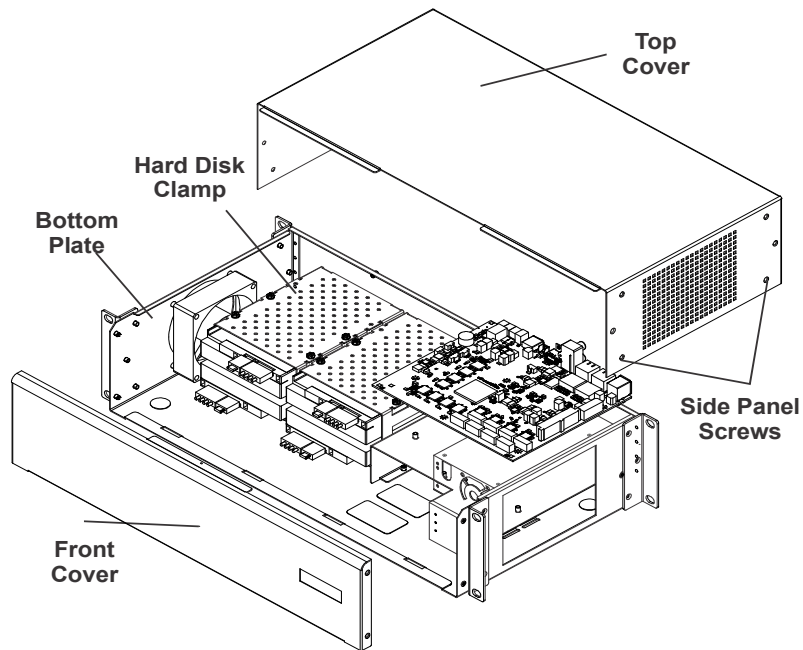

4. Fix the clamp fitted Hard disks on the bottom plate with screws available at the rear and side panel.



Maximum torque to be applied for tightening the screws is 3 kgf.cm. Applying more than specified torque will cause a damage to the HDD and the clamp.

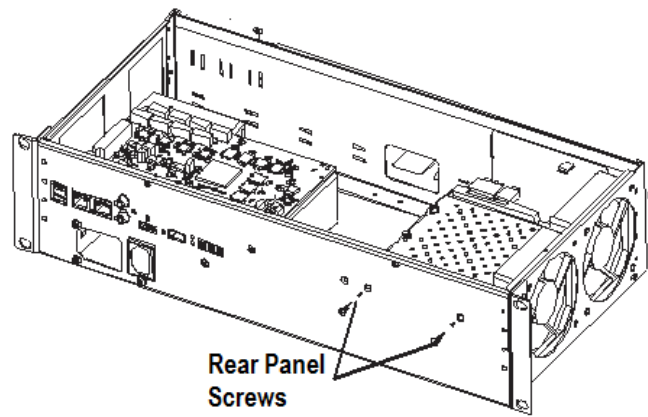

Similar alignment can be done in NVR6408X/NVR6408X P2/NVR9608X P2 with the eight Hard Disks as shown below.

NVR6408X/NVR6408X P2/NVR9608X P2

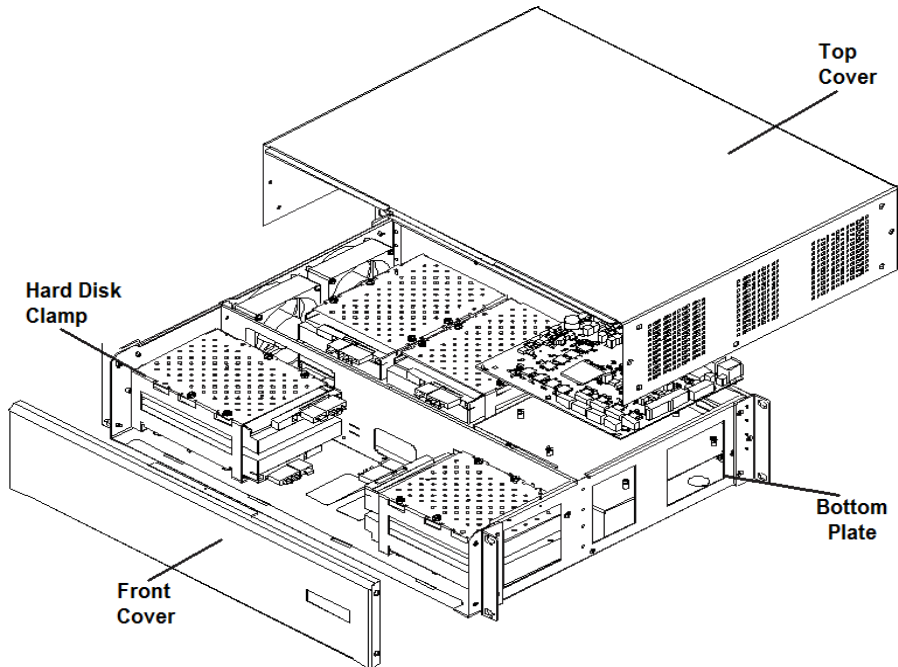

Hard Disk Cable Routing

1. Inside the package you will find four SATA cables in NVR3204X and NVR6404X and eight in NVR6408X, NVR6408X P2 and NVR9608X P2 for each hard disk.
2. Plug the SATA cables and power cables into the respective connectors shown below on the hard disk.

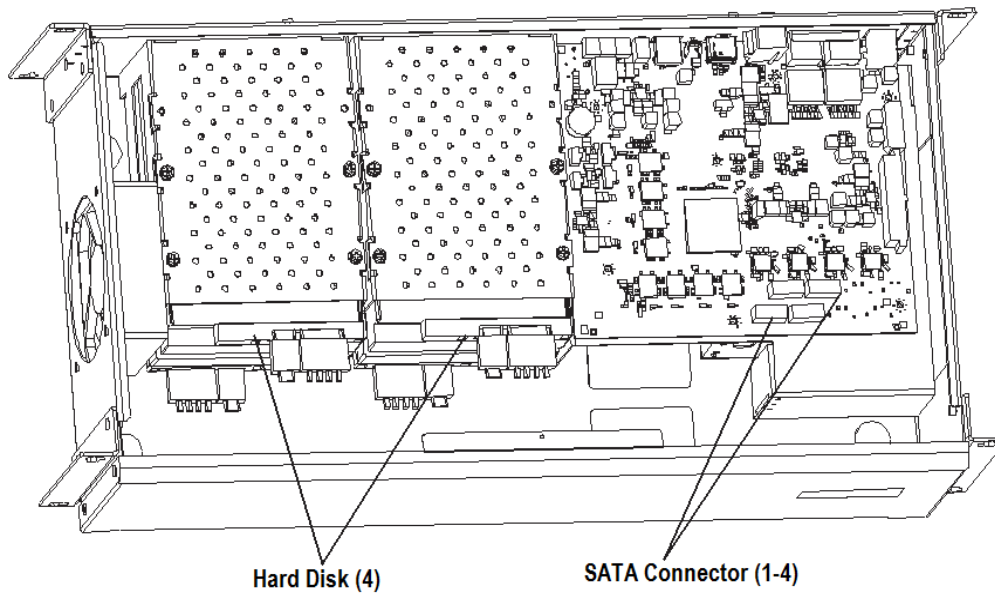

Similar connection can be done in **NVR6408X/NVR6408X P2/NVR9608X P2**. Connectors are shown below.

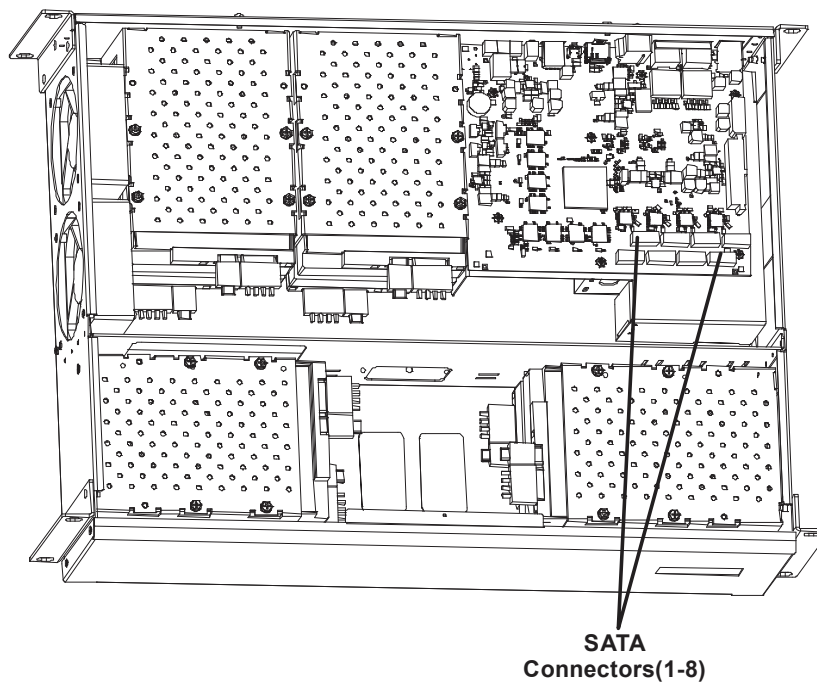

Installing HDD in other NVR Variants

Follow these instructions to install a disk:

1. Switch off power to the unit. Unplug the power adapter, if you have connected it to the SATATYA NVR.
2. Remove the upper cover from the SATATYA NVR. The top cover screws are located on the rear panel and the side panels. See [“SATATYA NVR Other Variants Dimensions” on page 59](#). Remove the top cover screws and slide open the cover.

NVR64P/S

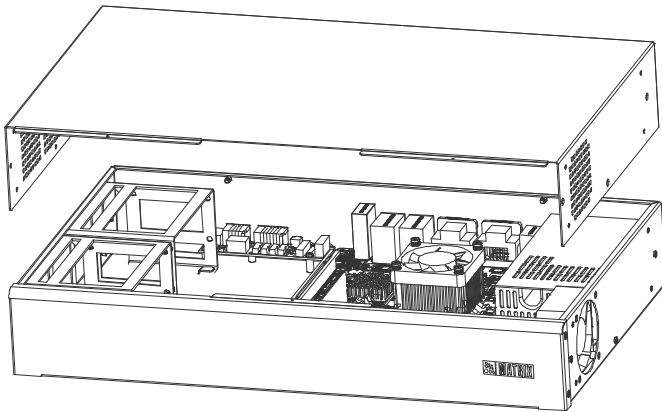

3. Take the Clamp and Place the Hard Disk inside the Clamp. Secure the hard disk inside the Clamp with the four screws provided using a magnetic screw driver.
4. Now Place the Clamp fitted with Hard disk on the bottom plate, align with the screws on the plate.

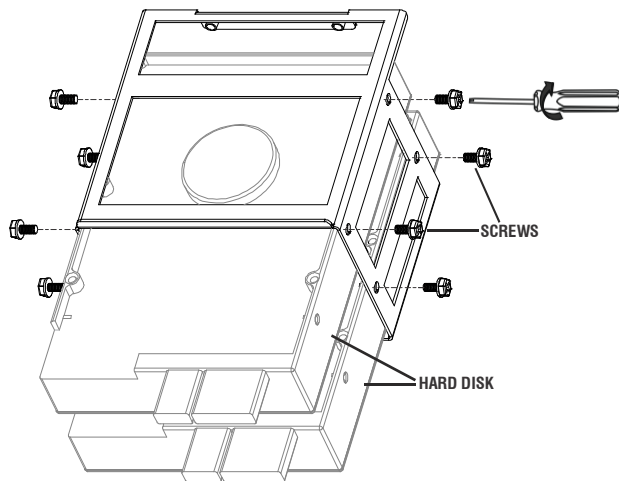

Maximum torque to be applied for tightening the screws is 3 kgf.cm. Applying more than specified torque will cause a damage to the HDD and the clamp.

5. Inside the package, you will find 4 SATA cables for each hard disk in NVR64, 2 SATA cables for each HDD in NVR24P and 1 in NVR8S.

NVR64P/S

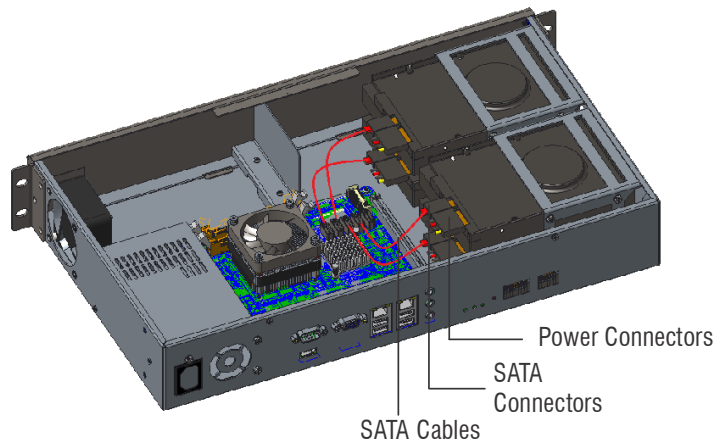

NVR24P

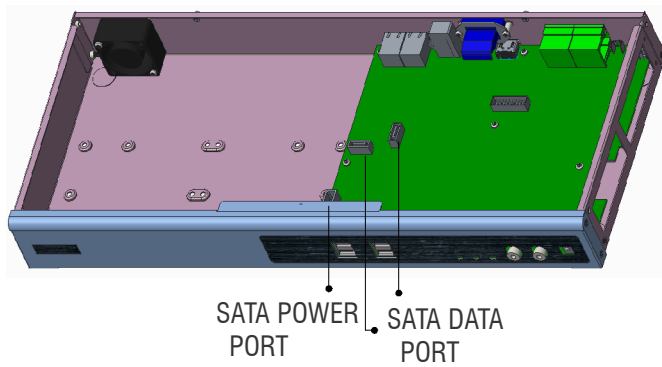

6. Place the Hard disk (2.5" or 3.5") on the bottom Plate, aligned with the screws on the plate. Secure the hard disk to the bottom plate with four screws provided with a magnetic screw driver.

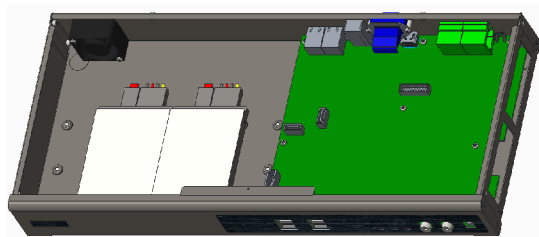

Mounting 2.5" HDD

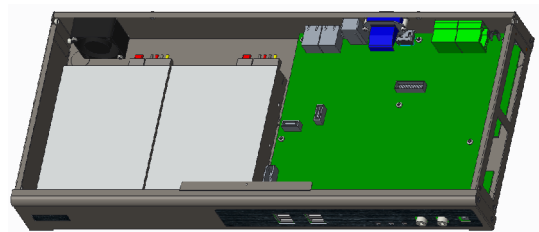

Mounting 3.5" HDD

7. Replace the top cover and secure it with the screws.
8. Apply power to the NVR only after you have completed the Installation. The system will now automatically detect the new disk(s).

9. You will need to format the hard disk to create the file system of the NVR on your disk.

NVR16H

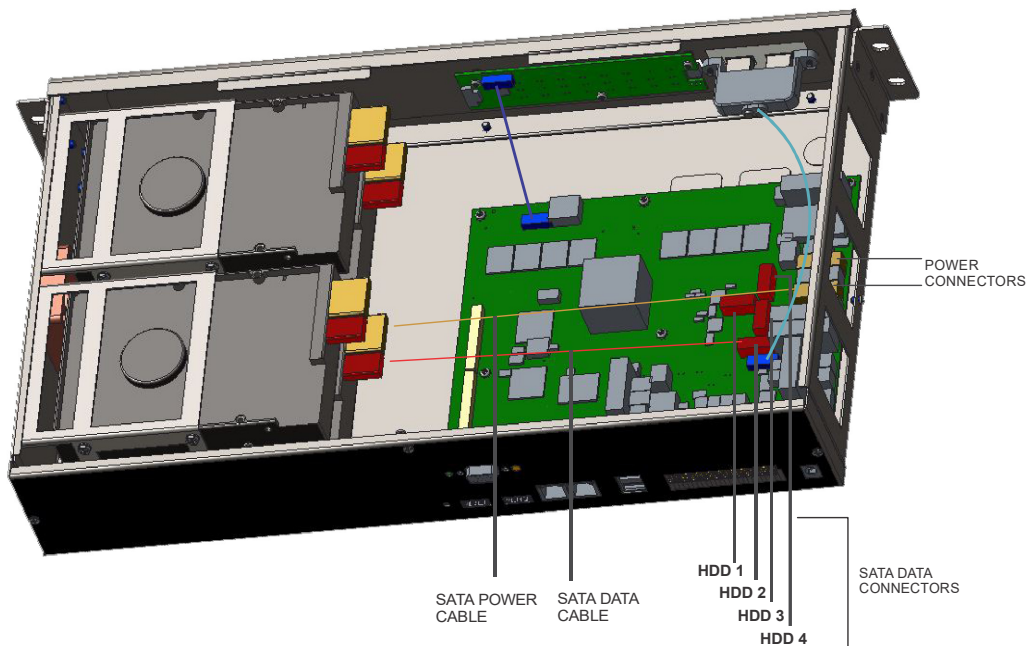

NVR16S

1. Place the Hard Disk on the bottom plate, aligned with the screws on the plate. Secure the hard disk to the bottom plate with the screws provided using a magnetic screw driver.
2. Plug the SATA power cable and the data cable into the respective connectors on the Hard disk.

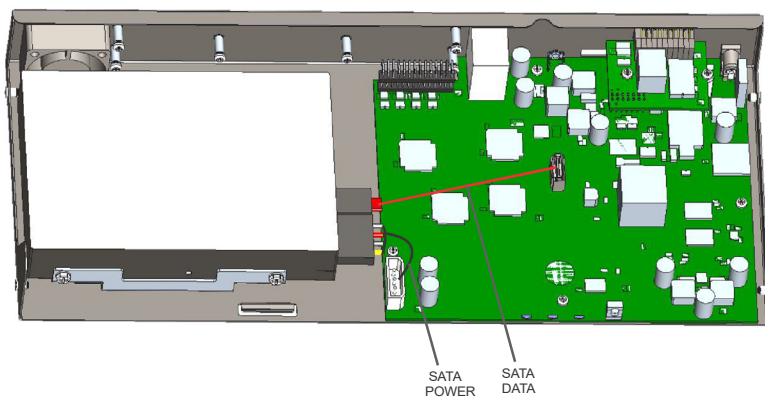

- Replace the top cover and secure it with the screws.

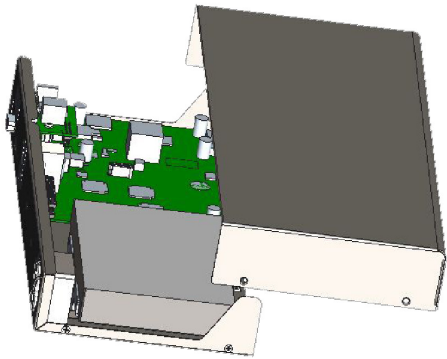

Installing HDD in HVR Variants

The SATATYA HVR board comes with on board SATA and power connectors.

HVR 1624P and HVR 0824P

HVR16/8P

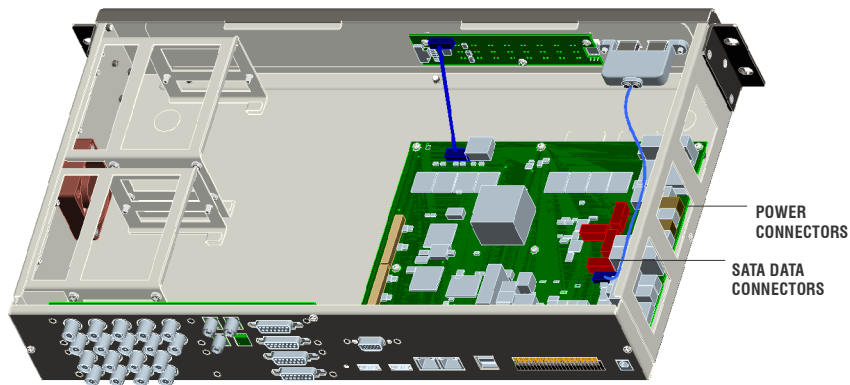

HVR 1624S and HVR 0824S

HVR16/8S

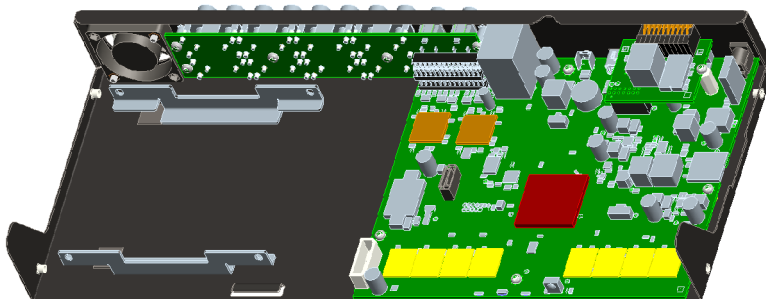

HVR 0408P and HVR 0408S

HVR4

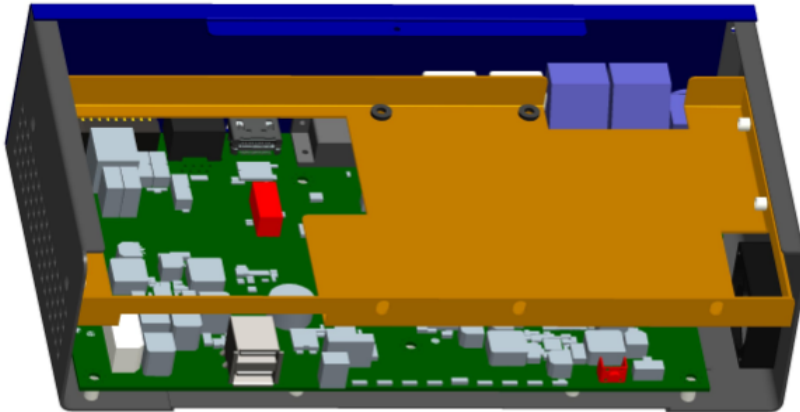

Follow these instructions to install a disk:

1. Switch off the power supply of the unit. Unplug the power adapter, if you have connected it to SATATYA HVR.
2. Remove the upper cover from the SATATYA HVR. The top cover screws are located on the rear panel and the side panels on HVR16/8 as shown below. Remove the top cover screws and slide open the cover.

HVR16/8P (HVR 1624P and HVR 0824P)

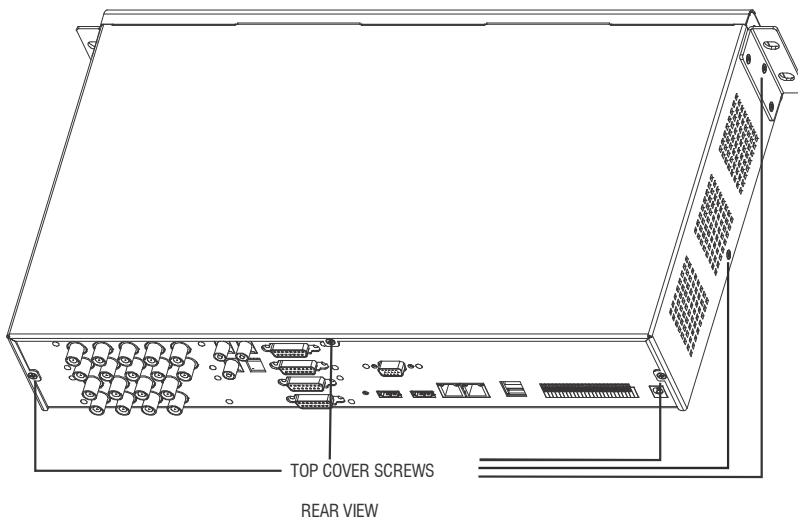

3. For HVR16/8P, take the Clamp and Place the Hard Disk inside the Clamp as shown below. Secure the hard disk inside the Clamp with the four screws provided using a magnetic screw driver.



Maximum torque to be applied for tightening the screws is 3 kgf.cm. Applying more than specified torque will cause a damage to the HDD and the clamp.

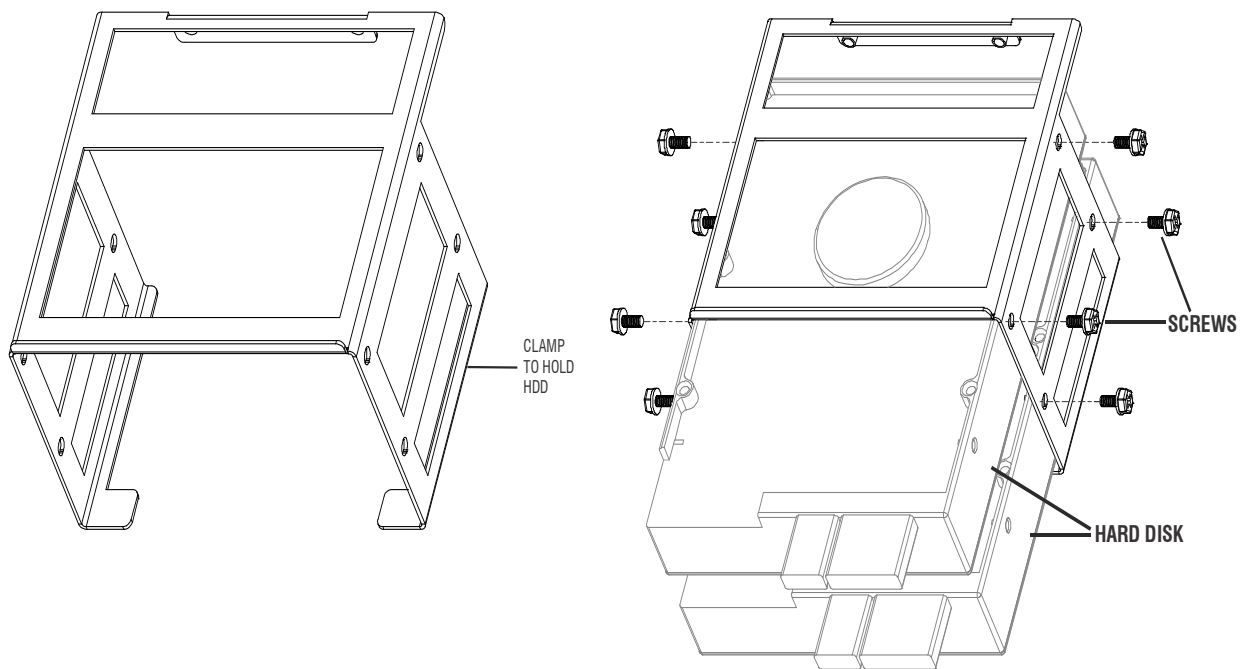

4. Now Mount the Hard disk with the Clamp on the bottom plate of the HVR, align with the screws on the plate.
5. Inside the device, you will find two sets of SATA power cable and data cable for each hard disk.

Connect the SATA power cable and the data cable into the respective connectors on the Hard disk and connect the other end of the cable to the SATA connectors on the main board as shown below.

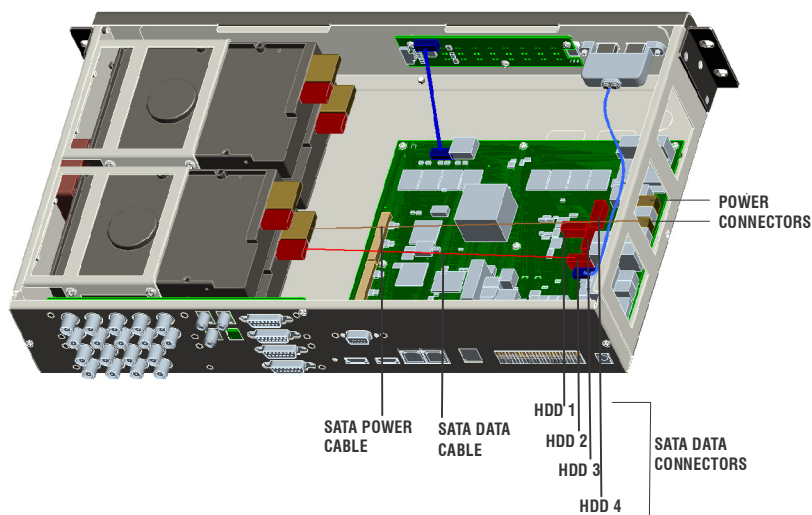

HVR 16/8S(HVR 1624S and HVR 0824S)

6. For HVR16/8S the top cover screws are located on the side panels as shown below. Remove the top cover screws and slide open the cover.

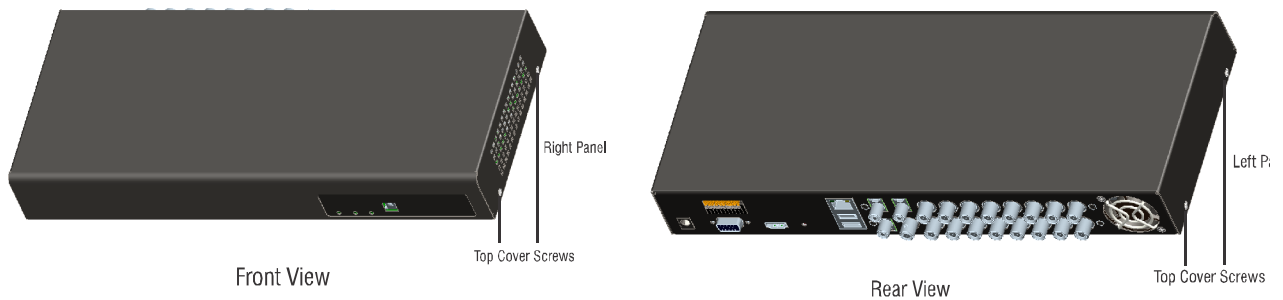

7. Place the Hard Disk inside the holder as shown below. Secure the hard disk on the bottom plate of the HVR inside the holder with the two screws provided using a magnetic screw driver.

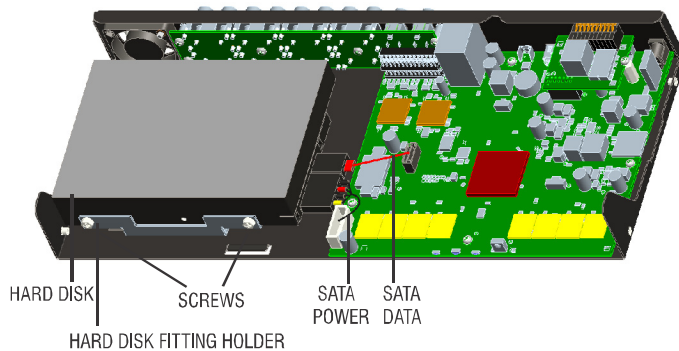

8. Inside the device, you will find SATA power cable and data cable for the hard disk.

Connect the SATA power cable and the data cable into the respective connectors on the Hard disk and connect the other end of the cable to the SATA connectors on the main board as shown above.

9. Replace the cover and screw it back into place. Power up the SATATYA HVR. The system will now automatically detect and format the new disk(s).

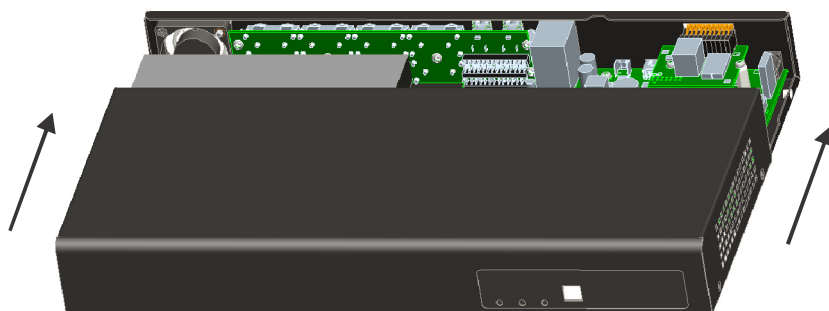

HVR 0408P

10. For HVR4, the top cover screws are located on the bottom side on HVR4 as shown below. Remove the top cover screws and slide open the cover.

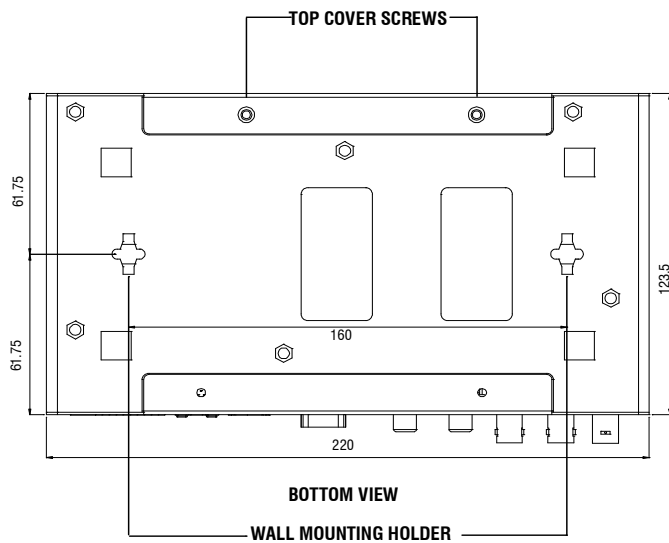

11. Mount the hard disk in HDD fitting plate. Connect the SATA Cable to the disk and connect the other end to the mother board.

12. Connect the Power Cable to the disk. Screw the disk holders in place inside the unit using 3 screws on the front plate of HDD fitting plate using a magnetic screw driver.

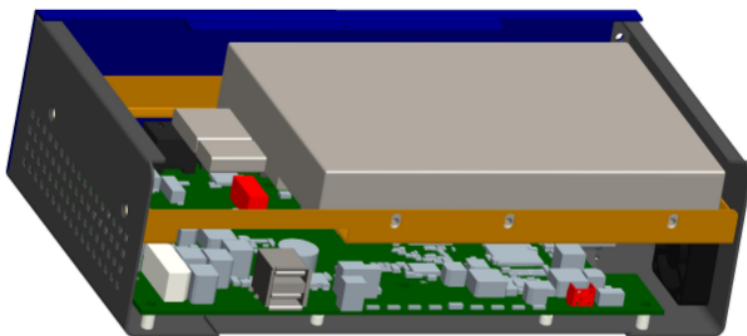

13. Replace the cover and screw it back into place. Power up the SATATYA HVR. The system will now automatically detect and format the new disk(s).

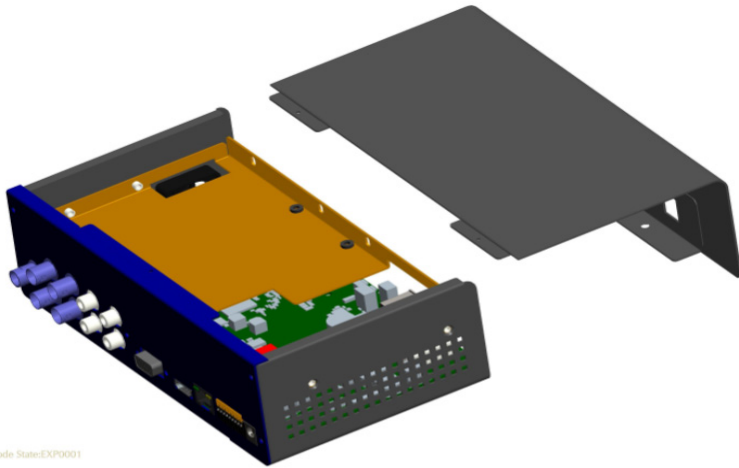

Apply power to the HVR only after you have completed the entire installation.

Hooking up Inputs

The SATATYA device such as NVR/NVRX/NVRX P2 and HVR has an on-board capability of monitoring sensor inputs which can be linked to Event and Action. The maximum distance of one line is 600 m (2,000 feet) with a two conductor cable having a gauge of AWG#22. One ground point is provided for the available inputs in devices.

The number of sensor inputs available in SATATYA devices are shown below:

SATATYA NVRX/ NVRX P2 Series Variants	NVR0401XS P2 / NVR0801XS P2 /NVR1601XS P2	NVR0801X/ NVR1601X NVR0801X P2/ NVR1601X P2	NVR1602X/ NVR3202X NVR1602X P2/ NVR3202X P2	NVR3204X/ NVR6404X/ NVR3204X P2/ NVR6404X P2	NVR6408X/ NVR6408X P2/ NVR9608X P2
Sensor Inputs availability	NA	Yes(2)	Yes(2)	Yes(2)	Yes(2)

SATATYANVR other Variants	NVR8S	NVR16S	NVR24P	NVR16H	NVR64P/S
Sensor Inputs availability	Yes(2)	Yes(4)	Yes(8)	Yes(8)	Yes(4)

SATATYAHVR Variants	HVR1624P	HVR1624S	HVR0824P	HVR0824S	HVR0408P	HVR0408S
Sensor Inputs availability	Yes(8)	Yes(4)	Yes(8)	Yes(4)	Yes(2)	No

These inputs operate with a simple On/Off function and the recording state can be controlled based on the state of the inputs.

Inputs can be connected to either NO (Normally Open) or NC (Normally Closed) type sensor contacts as shown in figure.

The installer can configure each input depending on the type. Connect one ground wire between the external device to the terminal block **GND** input on the NVR/HVR as shown. Connect the other wire to the sensor input **1–8** connection on the terminal block.

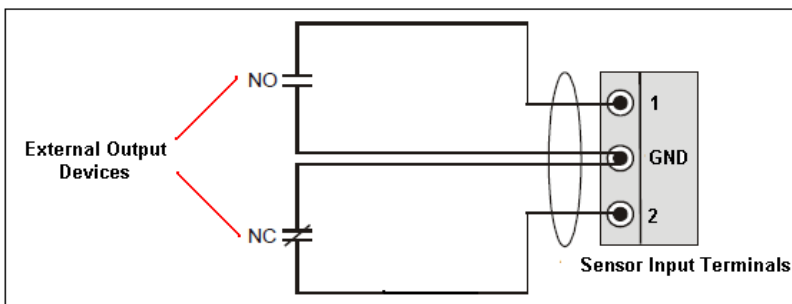

The user can connect the output from another device, For e.g. a fire alarm relay or the AUX relay of a DOOR Controller can be connected to one of the Inputs and an Event and Action mapping can be defined to link the input event to the desired action.

The number of Ethernet ports of various STATATYA devices have been classified in the following tables. These ports can be configured from the Network parameters section.

NVRX/NVRX P2 Series variants

Ethernet	NVR0401XS P2 / NVR0801XS P2 / NVR1601XS P2	NVR0801X/ NVR1601X NVR0801X P2/ NVR1601X P2	NVR1602X/ NVR3202X NVR1602X P2/ NVR3202X P2	NVR3204X/ NVR6404X/ NVR3204X P2/ NVR6404X P2	NVR6408X/ NVR6408X P2/ NVR9608X P2
No. of Ethernet Ports	1 RJ45 1000 Mbps port	1 RJ45 1000 Mbps port	2 RJ45 1000 Mbps port	2 RJ45 1000 Mbps port	2 RJ45 1000 Mbps port

Other NVR variants

Ethernet	NVR8S	NVR16S	NVR24P	NVR16H	NVR64P/S
No. of Ethernet Ports	1 RJ45 100 Mbps port	1 RJ45 100 Mbps port	2 RJ45 Gigabit ports	2 RJ45 1000 Mbps ports	2 RJ45 Gigabit ports

HVR variants

Ethernet	HVR1624P	HVR1624S	HVR0824P	HVR0824S	HVR0408P	HVR0408S
No. of Ethernet Ports	2 RJ45 1000 Mbps ports	1 RJ45 100 Mbps port	2 RJ45 1000 Mbps ports	1 RJ45 100 Mbps port	1 RJ45 100 Mbps port	1 RJ45 100 Mbps port

The SATATYA device comes factory configured with the following default IP address settings.

Ethernet Port 1 default settings:

IP Address: 192.168.1.123

Subnet Mask: 255.255.255.0

Gateway Address: 192.168.1.1

Ethernet Port 2 default settings:

IP Address: 192.168.2.2

Subnet Mask: 255.255.255.0

Gateway Address: 192.168.2.1

Accessing the Local Client

To access the Local Client, you need to connect a Monitor, Keyboard and Mouse / LAN PC to the NVRX, Default IP Address: 192.168.1.123 (LAN1).

 *Make sure the LAN PC and NVRX are in the same network.*

- Switch on power supply to your NVRX.
- The Matrix corporate logo will appear on your screen.
- The default Live View monitoring layout (4x4) will appear on your monitor screen.
- Hover the mouse at the bottom of the monitor screen to invoke the Toolbar, click **Login** .

 *If you have connected a PC in your LAN with NVRX as well as cameras are connected in the same network, then these cameras can be added directly. A pop-up confirming the same appears. Click **Yes** to confirm.*

Login - Local Client

- The **Login** pop-up appears.

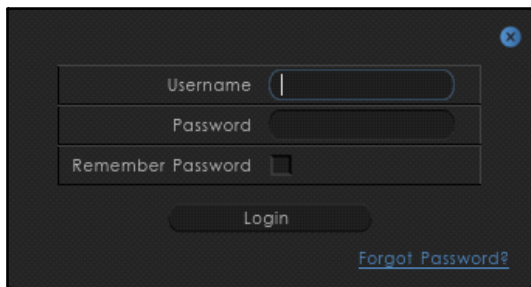

 *The **Forgot Password** link is applicable for NVRX/NVRX P2 series only.*

- Enter the **Username** (default: admin) and **Password** (default: admin). Click **Login**. The **Please set your password** pop-up appears.

 *For other user login except admin, you need to enter the Username and Password as set by the admin.*

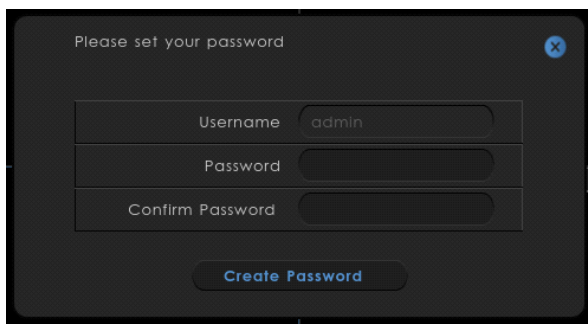

- In **Password**, enter the password you wish to set.

The New Password must have atleast:

- a minimum of 5 characters to a maximum of 16 characters.
- 1 Uppercase (A-Z)
- 1 Lowercase (a-z)
- 1 Number (0-9)
- 1 Character - _ . () [] : @ ! # \$ * + \ /

You can change the parameters of the Password Policy. For details, refer to [“Password Policy”](#).

- In **Confirm Password**, re-enter the new password to confirm.
- Click **Create Password**. The **Password Recovery** pop-up appears.

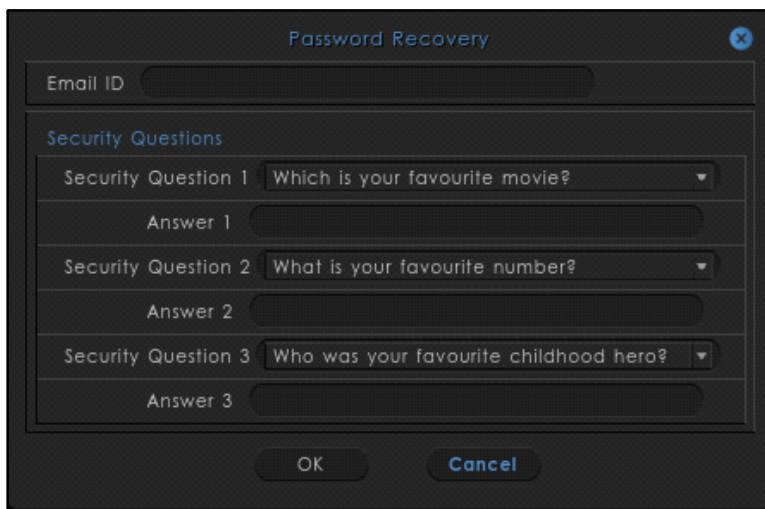

The screenshot shows a dark-themed dialog box titled "Password Recovery" with a close button (X) in the top right corner. It contains an "Email ID" input field. Below it is a "Security Questions" section with three rows. Each row has a dropdown menu for a question and a corresponding text input field for the answer. The questions are: "Which is your favourite movie?", "What is your favourite number?", and "Who was your favourite childhood hero?". At the bottom of the dialog are "OK" and "Cancel" buttons.



*The **Password Recovery** pop-up is applicable for NVRX/NVRX P2 series only.*

You can configure the Email ID and/or Security Questions which will be used to recover the password if user forgets the password.

Enter the Email ID through which the password recovery will be done.

Select the Security Questions from the drop-down list. Specify the answers for each of them. Click **OK** to save the settings or click **Cancel** to discard.

If you do not wish to set the Email ID or Security Questions at the time of login, you can set them later. To do so, refer to [“Password Recovery”](#).

- You will be re-directed to the Login page again.

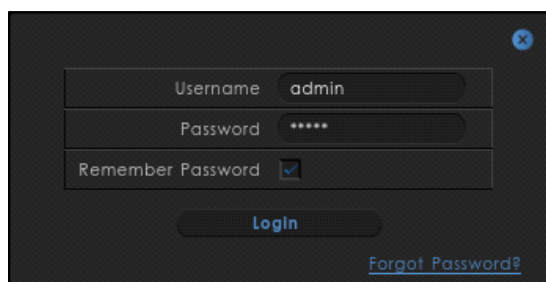

The screenshot shows a dark-themed login form. It has three input fields: "Username" with the text "admin", "Password" with masked characters "*****", and "Remember Password" with a checked checkbox. Below the fields is a "Login" button. At the bottom right, there is a blue link that says "Forgot Password?".

- The **Username** and **Password** are auto-filled. The password is the one you set in the **Create Password** pop-up.
- Select the **Remember Password** check box if required. The system will not prompt you for the password for subsequent logins.
- Click **Login**. The **Quick Setup Wizard** pop-up appears. It allows you to set up the basic parameters of NVRX like Time and Language, Network, DHCP Server, Storage, Camera Configuration and Search Camera quickly. For more details, refer to "[Quick Setup Wizard](#)".

Forgot Password- Local Client



Only 10 different users can simultaneously reset the password at a time.

The **Reset Password** feature is applicable for NVRX/NVRX P2 series only.

- Click **Forgot Password** on the login page. The **Reset Password** pop-up appears.

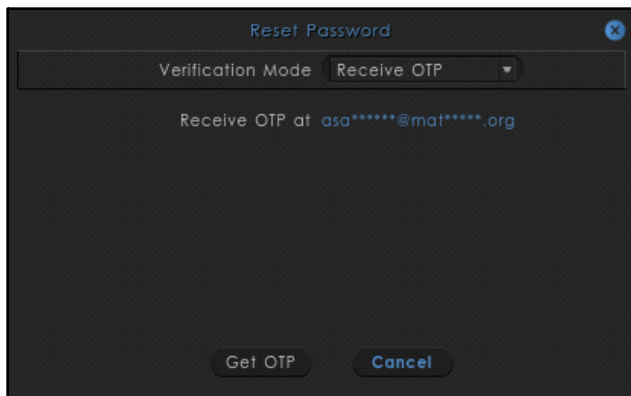

- Select the desired option for **Verification Mode** — Email ID or Security Questions.

If you select **Email ID** as the **Verification Mode**,

- Click **Get OTP** to receive the 6-digit OTP on the configured Email ID.
- Enter the received OTP. The OTP is valid for 2 minutes. Click **Verify**. You will be redirected to Create Password page.

If you select **Security Questions** as the **Verification Mode**,

- Specify the answers for the set Security Questions.

 The user can enter incorrect OTP or answers of the Security Questions until the Maximum Failed Login Attempts is reached. If user enters incorrect OTP or answers of the Security Questions above the defined number of attempts, the user will be redirected to the login page and the account will be locked. The account will remain locked for the duration as configured under the Account Lockout Policy. For more details, refer to [“Password Policy”](#).

- Click **Verify**. You will be redirected to **Create Password** page.
- Create the password as explained above. Click **Login**.

Installing and Accessing the Device Client

To install and access the Device Client,

- Open the browser window on the PC (make sure the PC is in the same Network as NVRX).
- In the Address bar of the browser window, enter the IP Address, for example LAN1: 192.168.111.165 as set from the Local Client. Press the Enter key on your keyboard.
- Click **Download** to download the Device Client Setup.

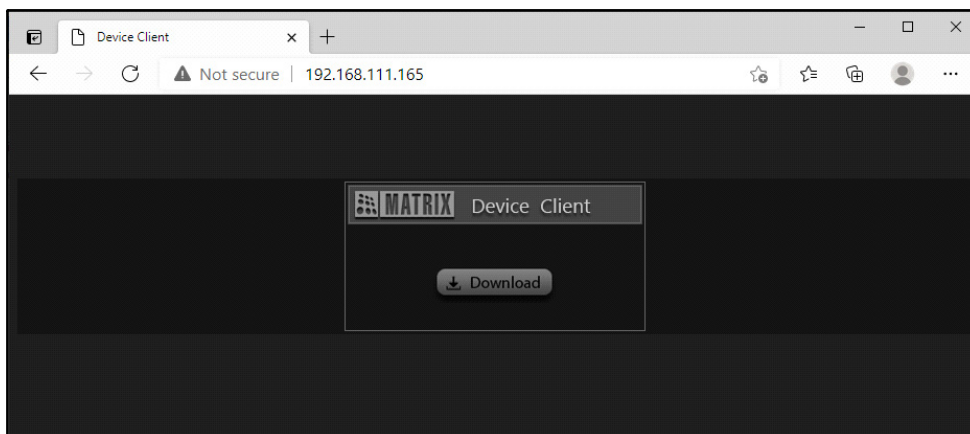

- Click on your PC search option and enter **Device Client Setup**. Click the same.

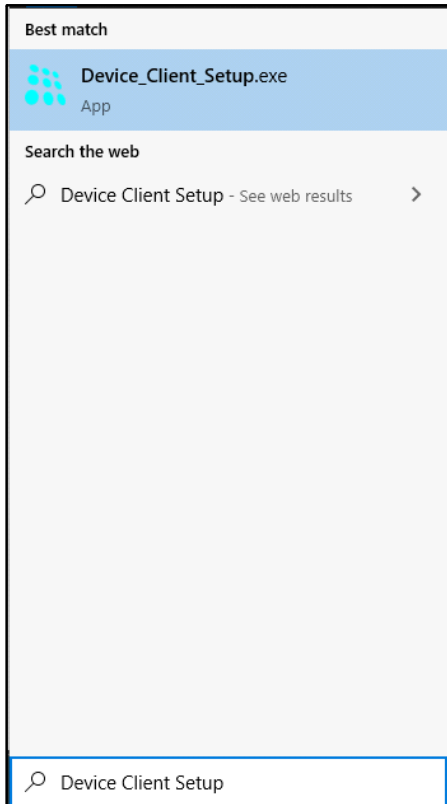

 *Make sure you run the setup from the administrator login.*

- The Device Client Setup installation window appears.

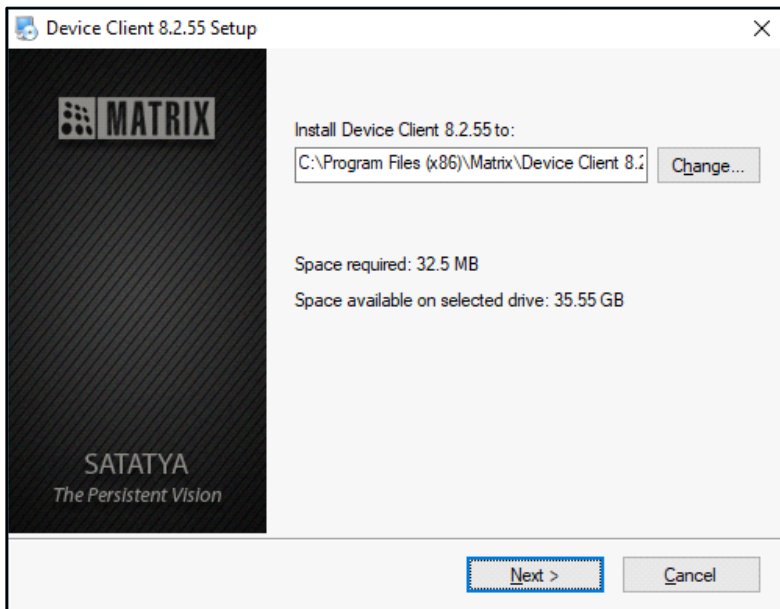

- The Default Path at which it will be installed appears. However, if required, you may change the Path of the folder where the Device Client is to be installed. Click **Next**.

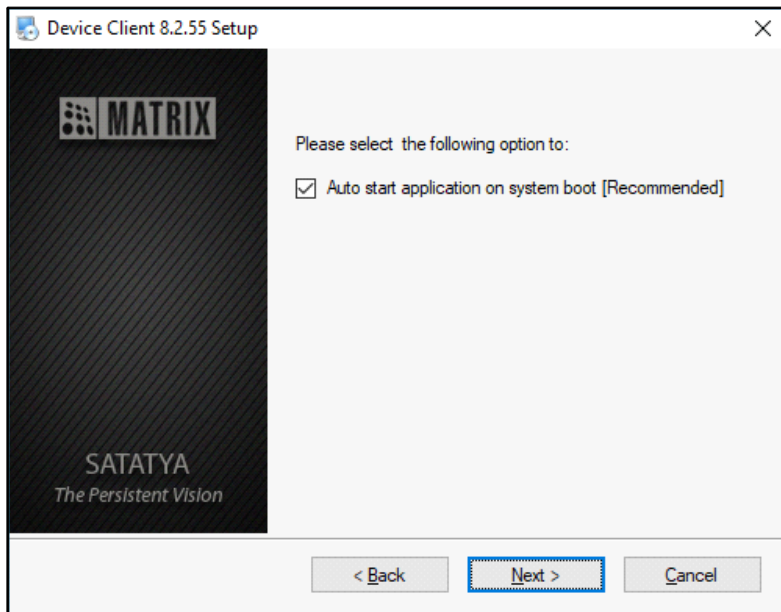

- Select the **Auto start application on system boot** check box, if you want the application to be launched every-time at the time of system boot. If enabled then the Device Client opens automatically on your screen, whenever the system boots.



If you have Device Client already installed on your PC and you are installing an upgraded version, the option for Multiple Installation appears. For example, you have installed Device Client 8.2.55 and now you are upgrading the same with 8.3.0.

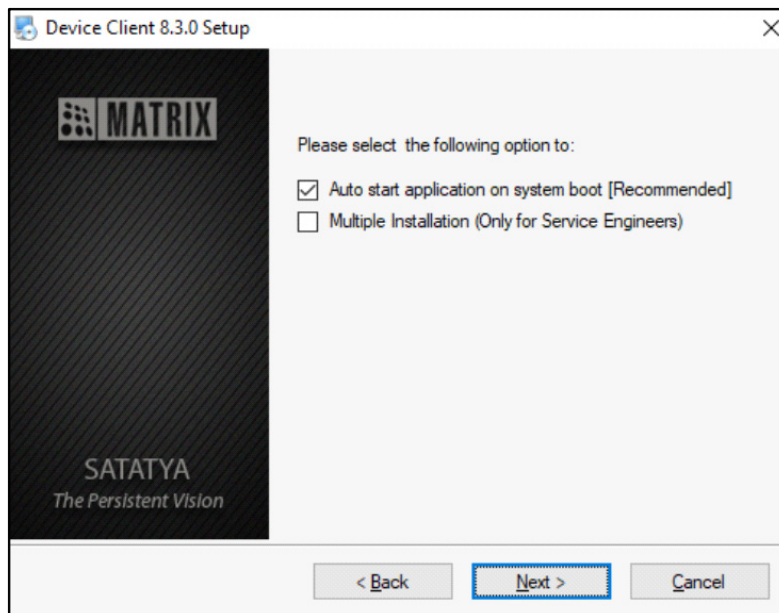

*The option **Multiple Installation** is only for the System Engineers and not for end users. User should not enable the same while installing the Device Client setup.*

For System Engineers, Multiple Installation will require an Authentication Key. Only after the successful authentication, they can proceed with the Multiple Installation. For Authentication Key, please contact our Technical Support Team.

- Click **Next** to install the Device Client. Once the installation is completed successfully, the following window appears.

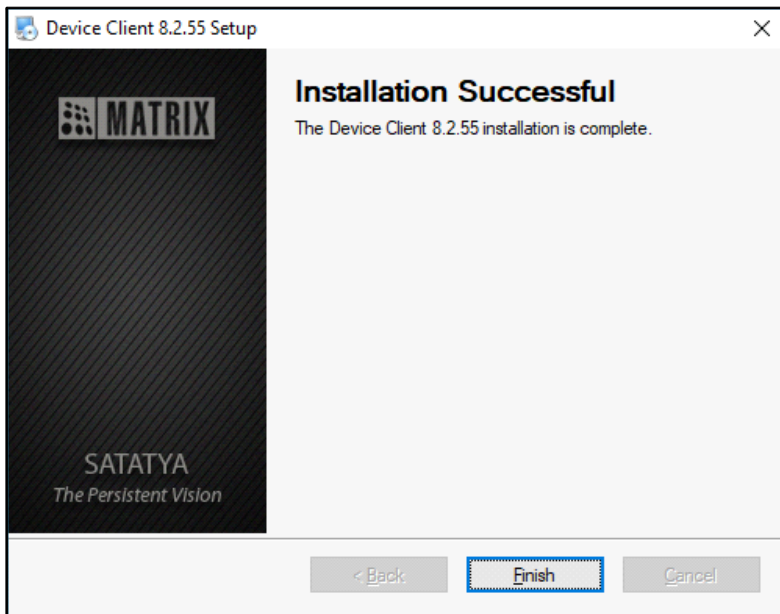

- Click on **Finish** to complete the installation.
- The Device Client  icon appears on the Windows Desktop.
- Double-click on the icon to launch the Device Client Application.
- The Login page appears. Enter the IP Address you set, for example 192.168.111.165 in the Address Bar and press Enter on your keyboard.



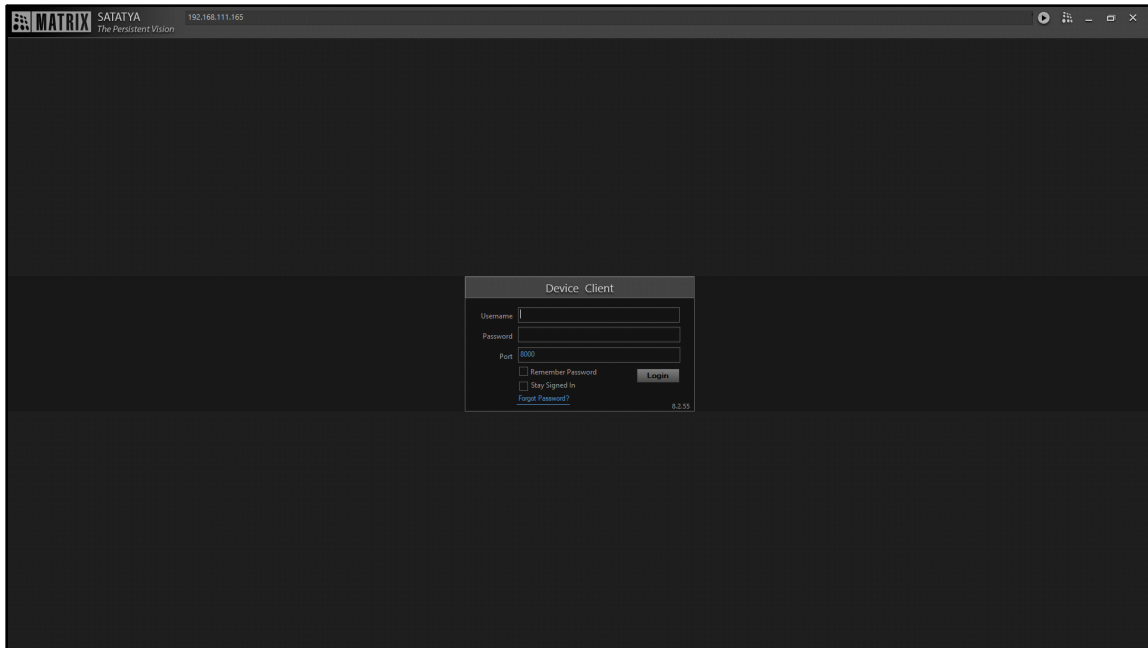

Login - Device Client

- The **Login** pop-up appears.

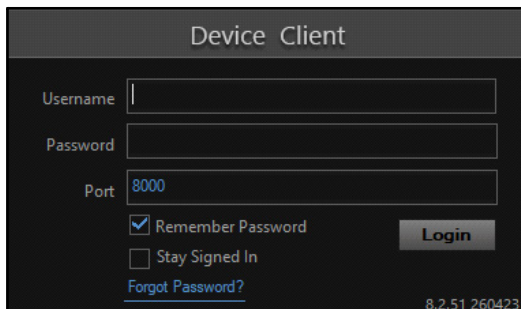

*The **Forgot Password** link is applicable for NVRX/NVRX P2 series only.*

- The **Username** and **Password** are auto-filled. The default **Port** is 8000. The password is the one that you set while accessing the Local Client for the first time. For details, refer to "[Login - Local Client](#)".



If you have not accessed the Local Client earlier, then you need to set the Password now from the Device Client. For details, refer to "[Login - Local Client](#)". Make sure your PC and NVR are in the same network. If you set the Password from the Device Client, then you can access the Local Client using the same Password.

- Click **Login**.

If you have not set the Password from Local Client, you can set it now from the Device Client.

- Enter the **Username** (default: admin) and **Password** (default: admin). Click **Login**. The **Change Password** pop-up appears.



For other user login except admin, you need to enter the Username and Password as set by the admin.

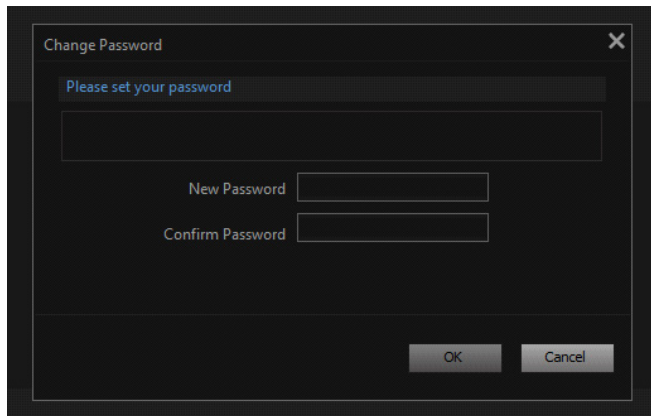

- In **Password**, enter the password you wish to set.

The New Password must have atleast:

- a minimum of 5 characters to a maximum of 16 characters.
- 1 Uppercase (A-Z)
- 1 Lowercase (a-z)
- 1 Number (0-9)
- 1 Character - _.,()[]:@!#\$*+^

You can change the parameters of the Password Policy, for details refer to [“Password Policy”](#).

- In **Confirm Password**, re-enter the new password to confirm.
- Click **Create Password**. The **Password Recovery** pop-up appears.

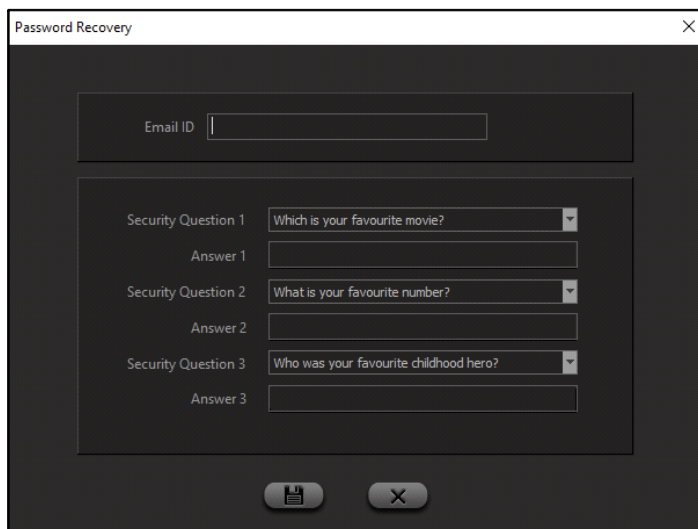

*The **Password Recovery** pop-up is applicable for NVRX/NVRX P2 series only.*

You can configure the Email ID and/or Security Questions which will be used to recover the password if user forgets the password.

Enter the Email ID through which the password recovery will be done.

Select the Security Questions from the drop-down list. Specify the answers for each of them. Click **OK** to save the settings or click **Cancel** to discard.

If you do not wish to set the Email ID or Security Questions at the time of login, you can set them later. To do so, refer to [“Password Recovery”](#).

- You will be re-directed to the Login page again.

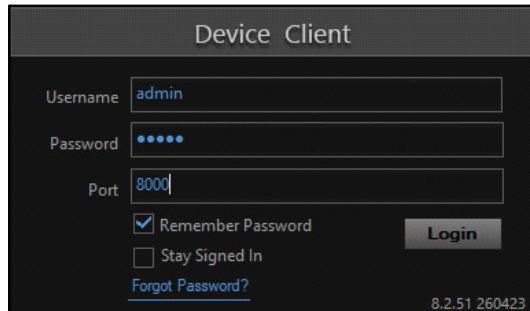

- The **Username** and **Password** are auto-filled. The password is the one you set in the **Create Password** pop-up. The default **Port** is 8000.
- Select the **Remember Password** check box if required. The system will not prompt you for the password for subsequent logins.
- Select the **Stay Signed In** check box if you wish to login automatically into Device Client, on launching the application next time.
- Click **Login**.
- The Device Client Live View screen appears, with the default display layout (2x2).

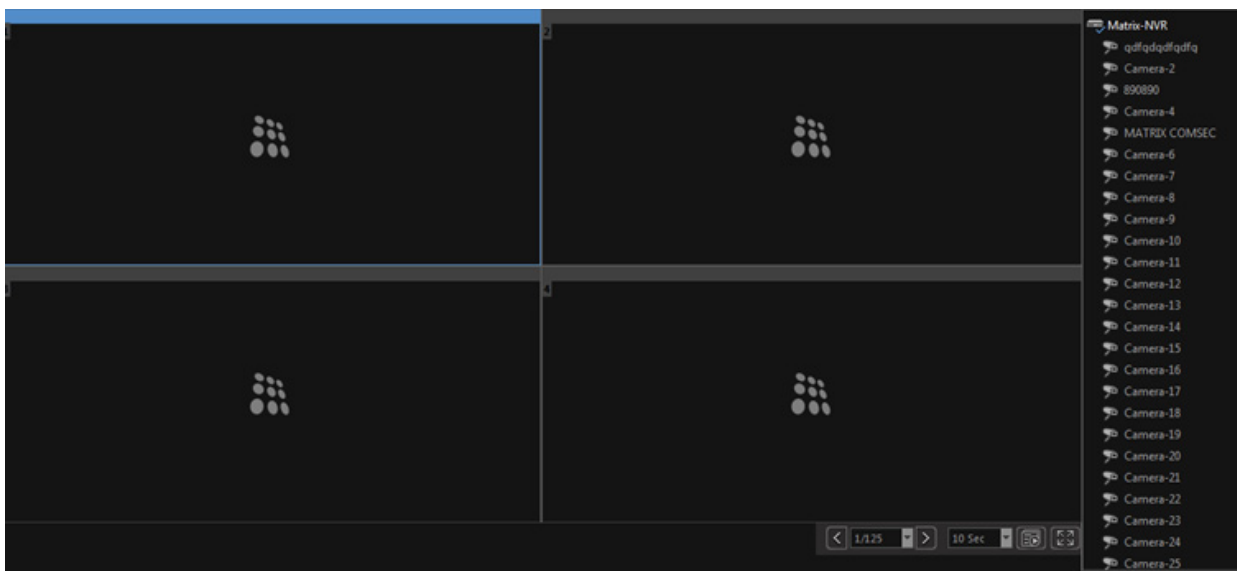

Click **Quick Setup**  from the left pane, if you wish to configure the basic parameters of NVRX such as Time and Language, Network, DHCP Server, Storage, Camera Configuration and Search Camera quickly. For more details, refer to [“Quick Setup”](#).

Forgot Password- Device Client



Only 10 different users can simultaneously reset the password at a time.

The **Reset Password** feature is applicable for NVRX/NVRX P2 series only.

- Click **Forgot Password** on the login page. The **Reset Password** pop-up appears.

The screenshot shows a 'Reset Password' dialog box with a dark background. At the top, it says 'Reset Password' with a close button (X). Below that, there is a 'Verification Mode' dropdown menu currently set to 'Receive OTP'. Underneath, it displays 'Receive OTP at swa*****@mat*****.org'. At the bottom, there are two buttons: 'Get OTP' and 'Cancel'.

- Select the desired option for **Verification Mode** — Email ID or Security Questions.

If you select **Email ID** as the **Verification Mode**,

- Click **Get OTP** to receive the 6-digit OTP on the configured Email ID.
- Enter the received OTP. The OTP is valid for 2 minutes. Click **Verify**. You will be redirected to Create Password page.

If you select **Security Questions** as the **Verification Mode**,

- Specify the answers for the set Security Questions.

The screenshot shows the 'Reset Password' dialog box with 'Security Question' selected in the 'Verification Mode' dropdown. It contains three security questions, each with a corresponding answer field. The questions are: 'Which is your favourite movie?', 'What is your favourite number?', and 'Who was your favourite childhood hero?'. At the bottom, there are 'Verify' and 'Cancel' buttons.











The user can enter incorrect OTP or answers for the Security Questions until the Maximum Failed Login Attempts is reached. If user enters incorrect OTP or answers for the Security Questions above the defined number of attempts, the user will be redirected to the login page and the account will be locked. The account will remain locked for the duration as configured under the Account Lockout Policy. For more details, refer to [“Password Policy”](#).

- Click **Verify**. You will be redirected to **Create Password** page.
- Create the password as explained above. Click **Login**.

Icon Representation

The following icons for cameras and devices appear in the Local Client and Device Client in NVRX/NVRX P2 series.

Icons	Description
Local Client Icons	
	Camera is Disconnected
	Camera is Connected
	Camera is Disconnected and Assigned
	Camera is Connecting and Assigned
	Camera is Connected and Assigned
	Camera Retry Connection and Assigned
	Assigns all the Cameras to the Monitoring Windows
	Unassigns all the Cameras to the Monitoring Windows
	Device is Connected
	Device is Disconnected
	Device Firmware Mismatch

Device Client Icons	
	Camera is Disconnected
	Camera is Connected
	Camera is Connected (Two Way Audio)
	Device is Disconnected
	Device is Connected
	Device is Connected (Two Way Audio)
	Device Firmware Mismatch (Disconnected)
	Device Firmware Mismatch (Connected)

Welcome to the SATATYA NVRX Quick Setup Wizard. It allows you to set up the basic parameters of NVRX like Time and Language, Network, DHCP Server, Storage, Camera Configuration and Search Camera quickly.

You can configure the Quick setup for Local Client once the device is powered On and logged in with the Username and Password. Whereas for the Device Client, it can be configured by clicking on **Quick Setup**  icon located in the left pane of the monitoring window.

For details, refer to [“Quick Setup”](#).

Quick Setup

The Quick Setup Wizard appears automatically in the Local Client. However in the Device Client you need to click

Quick Setup  from the left pane.

The Quick Setup Wizard configurations in the Local Client and the Device Client are similar.

Quick Setup Wizard configurations in the Local Client are as follows:

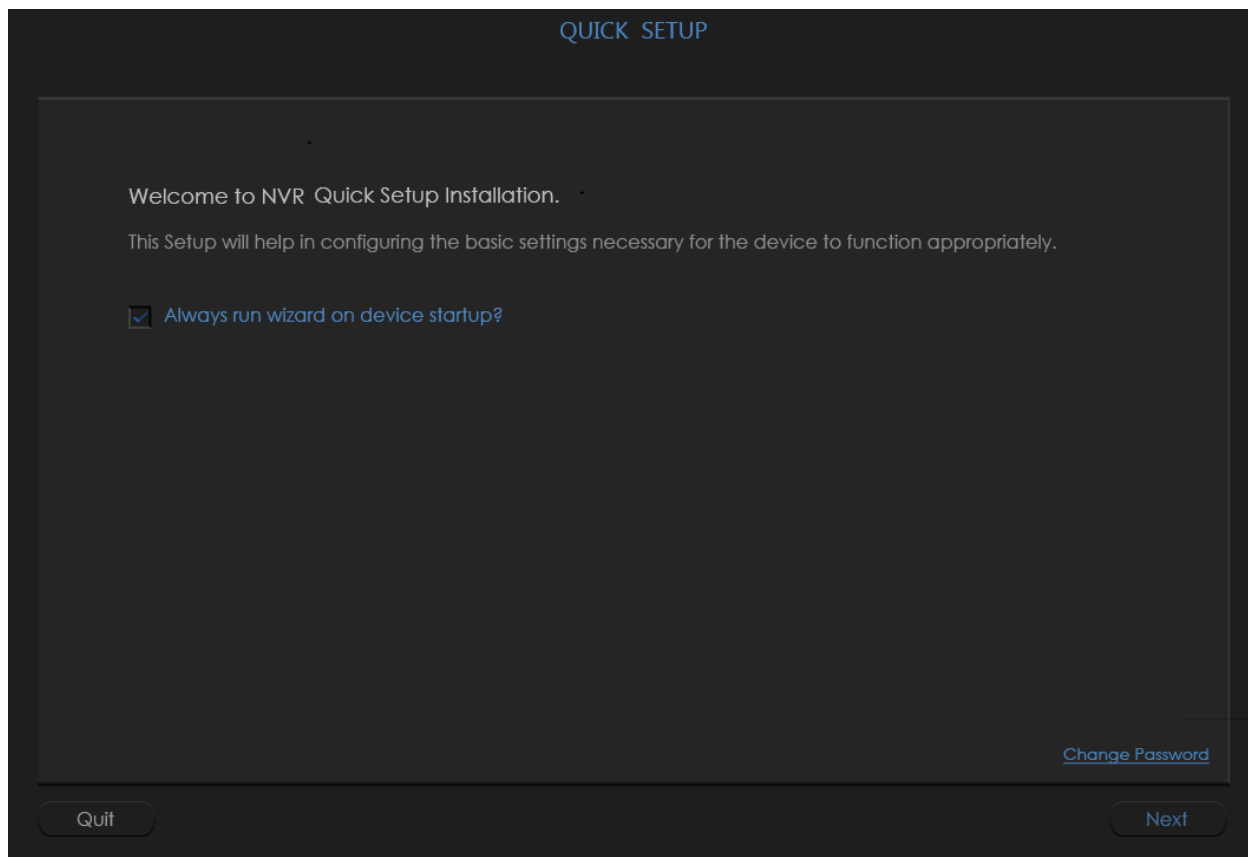

The **Always run wizard on device startup** check box will be selected by default and the Quick Setup Wizard will appear automatically every-time the device starts and is logged in again.



Always run wizard on device startup option appears only in the Local Client.

To navigate through the Quick Setup Wizard, click **Next**. Click each link for details:

[“Time and Language”](#)

[“Network”](#)

[“DHCP Server”](#)

[“Storage”](#)

[“HDD Group”](#)

[“Configure Camera”](#)

[“Search Camera”](#)

[“Status”](#)

Time and Language

Configure the Time and Language settings as follows:

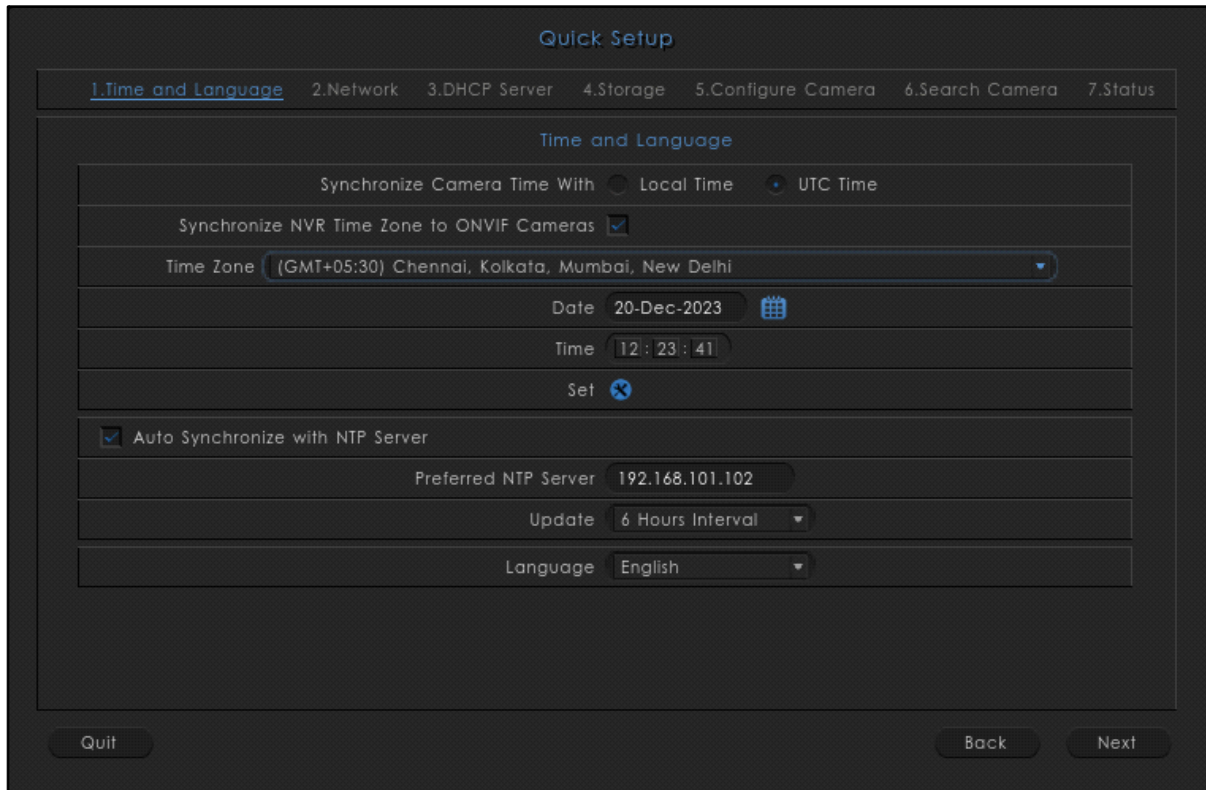

Synchronize Camera Time With: Select the radio button of the desired option — **Local Time** or **UTC Time** — with which the time of the Camera is to be synchronized.

- **Local Time:** Selecting this option will update the time of the camera as per the current time of SATATYA Device. Also, the Time Zone of camera will be changed to the Standard Time Zone (GMT) accordingly.
- **UTC Time:** Selecting this option will update the time of the camera as per the running time in SATATYA Device but, it will not affect the Time Zone of the camera. If the **Synchronize NVR Time Zone to ONVIF Cameras** option is enabled then current Time Zone of the camera will also be updated as per the configurations in SATATYA Device.

Synchronize NVR Time Zone to ONVIF cameras: Select this check box to sync the Time Zone as well as Date and Time of NVRX with the connected cameras.



*The **Synchronize NVR Time Zone to ONVIF Cameras** is applicable only if **UTC Time** is selected as the **Synchronize Camera Time With** option.*

Time Zone: Select the relevant Time Zone based on the location from the drop-down list.

Date: Set the Date by clicking on the calendar icon.

Time: Set the Time in 24 hours format. Click each option — HH, MM, SS — and then select the desired value from the drop-down list.

Set: Click **Set** to save the settings.

Auto Synchronize with NTP Server: Select this check box if you wish to allow synchronization of the Device Date and Time with that of the NTP Server.

Preferred NTP server: You can specify the IP Address or Host Name of the preferred NTP Server to be used to update and synchronize System's Real Time Clock periodically at defined time interval. For example: NIST.

Update: The Update Interval specifies the time period in hours between successive time synchronizations. Select the desired option from the drop-down list — Every 6 Hours, Every 12 Hours, Every 24 Hours.



The Date and Time of cameras added through ONVIF in the device will be same as set in the Time and Language page.

Language: Select the required Language from the drop-down list. This will be set as the default language of the Local as well as Device Client.



- The Language feature is applicable only for SATATYA NVRX/NVRX P2 variants.*
- The other Languages except English must be configured first by Admin group users from the Device client so that they appear in the Language drop-down list.*
- The updated language will be reflected in the Device Client or vice-versa after next login.*

Network

Configure the Network parameters for **LAN 1** and **LAN 2** as follows:

LAN 1

The screenshot displays the 'Quick Setup' interface for network configuration. At the top, there is a progress bar with steps: 1. Time and Language, 2. Network (highlighted), 3. DHCP Server, 4. Storage, 5. Configure Camera, 6. Search Camera, and 7. Status. Below this, the 'Network' section is active. It features a 'LAN' dropdown menu currently set to 'LAN 1'. The configuration options are as follows:

Field	Value
IP Assignment Mode	Static (selected), DHCP
IP Address	192.168.101.88
Subnet Mask	255.255.255.0
Default Gateway	192.168.101.1
DNS Mode	Static (selected), Automatic
Preferred DNS	192.168.109.10
Alternate DNS	192.168.52.1

At the bottom of the configuration area, there are three buttons: 'Quit', 'Back', and 'Next'.

Select the LAN 1 from the **LAN** drop-down list.

IP Assignment Mode

The SATATYA NVRX/ NVRX P2 has three modes of IP assignment based on which the network settings of the NVRX can be configured. You can configure two modes — Static, DHCP — from the Quick Setup Wizard as follows:

Static: Click the Static radio button to select this option and configure the following parameters:

- **IP Address:** Configure an IP Address to be assigned to the LAN Port of NVRX/ NVRX P2.
- **Subnet Mask:** Configure the Subnet Mask to be assigned to the LAN Port of NVRX/ NVRX P2.
- **Gateway:** Configure the IP Address of the Gateway to be assigned to the LAN Port of NVRX/ NVRX P2.

DHCP: Click the DHCP radio button to select this option. The DHCP Server automatically assigns an IP Address, Subnet Mask and Gateway Address to the LAN Port of NVRX/ NVRX P2.

Quick Setup

1. Time and Language 2. Network 3. DHCP Server 4. Storage 5. Configure Camera 6. Search Camera 7. Status

Network

LAN LAN 1

IP Assignment Mode Static DHCP

IP Address 192.168.101.88

Subnet Mask 255.255.255.0

Default Gateway 192.168.101.1

DNS Mode Static Automatic

Preferred DNS 192.168.109.10

Alternate DNS 192.168.52.1

Quit Back Next

DNS Mode

The DNS Settings enables you to specify the Server that normally provides the translation of Domain Names to IP Addresses in your network.

If you have selected **IP Assignment Mode** as **DHCP**, you can select either **Automatic** or **Static** as the DNS Mode.

If you select the **Automatic** radio button the DNS Server in your network will automatically provide the translation of Domain Names to IP Addresses.

If you select the **Static** radio button, then configure the **Preferred DNS Server** and **Alternate DNS Server** (if required).

If the Preferred DNS Server is not able to resolve a domain name immediately, it will then distribute the domain name query to Alternate DNS Server in the network.

The Alternate DNS Server, will provide the domain name translation if the Preferred DNS Server is unavailable to do so.



The configuration of selected option (LAN 1 or LAN 2) will be saved once it is switched from LAN 1 to LAN 2 or vice versa.

LAN 2

Select the LAN 2 from the **LAN** drop-down list.

The screenshot shows the 'Quick Setup' interface with the 'Network' section selected. The 'LAN' dropdown menu is set to 'LAN 2'. Below it, the 'IP Assignment Mode' has the 'Static' radio button selected. The 'IP Address' field contains '192.168.101.88', the 'Subnet Mask' field contains '255.255.255.0', and the 'Default Gateway' field contains '192.168.101.1'. At the bottom of the screen, there are 'Quit', 'Back', and 'Next' buttons.

For LAN 2, you can configure two modes — Static, DHCP— as IP Assignment Mode.

Static: Click the Static radio button to select this option and configure the following parameters:

- **IP Address:** Configure an IP Address to be assigned to the LAN Port of NVRX/ NVRX P2.
- **Subnet Mask:** Configure the Subnet Mask to be assigned to the LAN Port of NVRX/ NVRX P2.
- **Gateway:** Configure the IP Address of the Gateway to be assigned to the LAN Port of NVRX/ NVRX P2.

DHCP: Click the DHCP radio button to select this option. The DHCP Server automatically assigns an IP Address, Subnet Mask and Gateway Address to the LAN Port of NVRX/ NVRX P2.



LAN 2 option will not be available for the devices having single LAN port and will be visible as per the NVRX/ NVRX P2 variant.

DHCP Server

Configure the DHCP Server parameters as follows:

Quick Setup

1. Time and Language 2. Network 3. DHCP Server 4. Storage 5. Configure Camera 6. Search Camera 7. Status

DHCP Server

Enable DHCP Server

Ethernet Port LAN 1

Start IP Address 192.168.101.100

Number of Hosts 16 (1-100)

Subnet Mask 255.255.255.0

Default Gateway 192.168.101.1

DNS Address 192.168.109.10

Lease Hours 24 (1-192)

IP List and Status >>

Note: On changing any parameter of DHCP Server or selected LAN port, the allocated IP List might get cleared

Quit Back Next

Enable DHCP Server: Select the check box to enable DHCP Server configuration.

Ethernet Port: Select the desired Ethernet Port — LAN 1, LAN 2— from the drop-down list.

Start IP Address: Specify the Start IP Address to be assigned to the DHCP Clients.

Number of Hosts: Specify the number of hosts to be assigned IP Address by the DHCP Server.

Subnet Mask: Specify the Subnet Mask of the DHCP Server.

Default Gateway: Specify the Default Gateway of the DHCP Server.

DNS Address: Specify the DNS Address to be assigned to the DHCP Clients.

Lease Hours: Specify the Lease Hours for which the IP Addresses are allocated to the DHCP Clients.

Click **IP List and Status** to fetch the list of IP Address assigned to the DHCP Clients by the DHCP Server.



- DHCP Server is applicable to NVRX/ NVRX P2 variants only.
- After completing the configurations if you change any parameter of the DHCP Server or LAN Port, the allocated IP List will get cleared.

Storage

You can configure the volume for the storage in NVRX/ NVRX P2. It supports different RAID levels for storing the data in multiple physical disks interfaced with the NVRX / NVRX P2.

RAID level is used to improve the performance of the system by load sharing and providing fault tolerance and redundancy. This maintains redundant data which can be used to restore data on the event of disk failure. SATATYA NVRX/ NVRX P2 Series variants supports RAID 0, RAID 1, RAID 5 and RAID 10 HDD modes.

Among all the NVRX/NVRX P2 variants, there is difference in number of available SATA interfaces and Ethernet ports. So based on SATA interfaces, RAID level can be configured.

For the detailed explanations of supported RAID types and to know more about RAID creation and Total Logical Volume in different NVRX/NVRX P2 series variants, refer to [“RAID Concept”](#).

Storage page appears on the screen as **No Disk Found** if the Hard Disks (HDD) are not connected with the device.

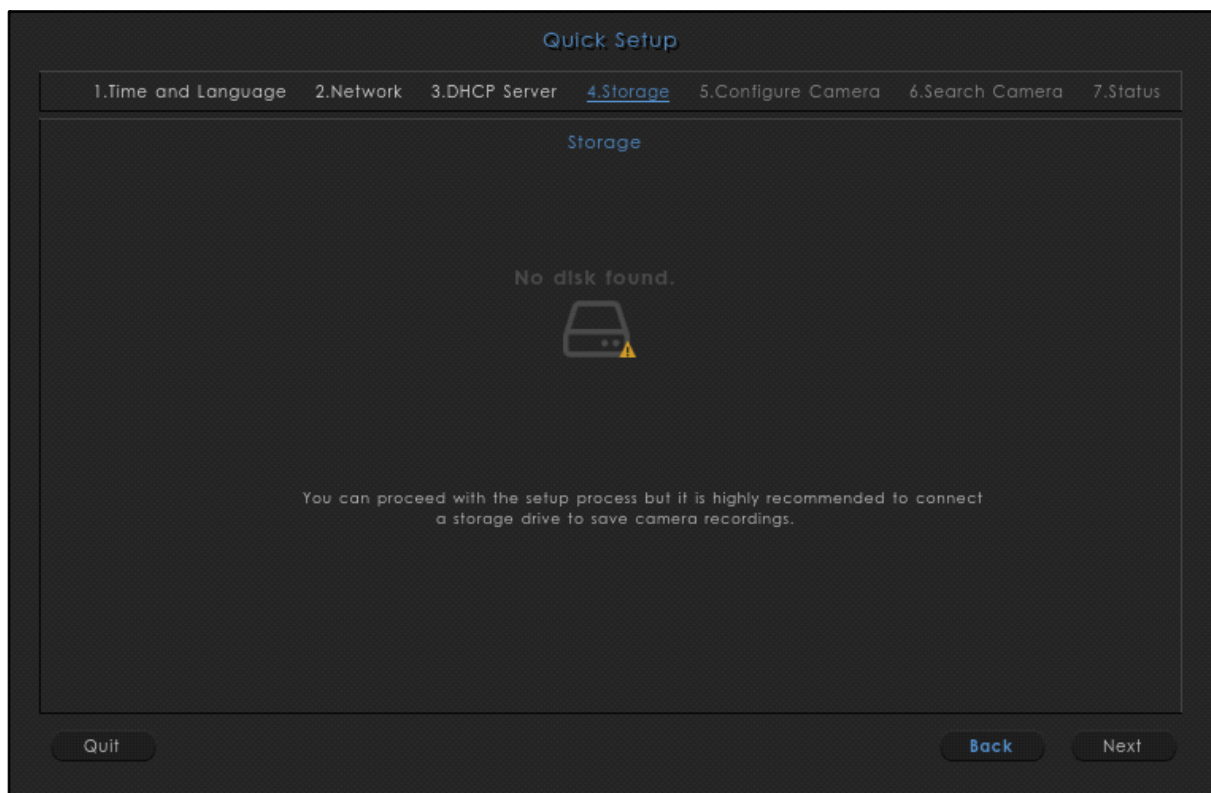

Once the HDDs are connected you can configure the storage for your NVRX as follows:

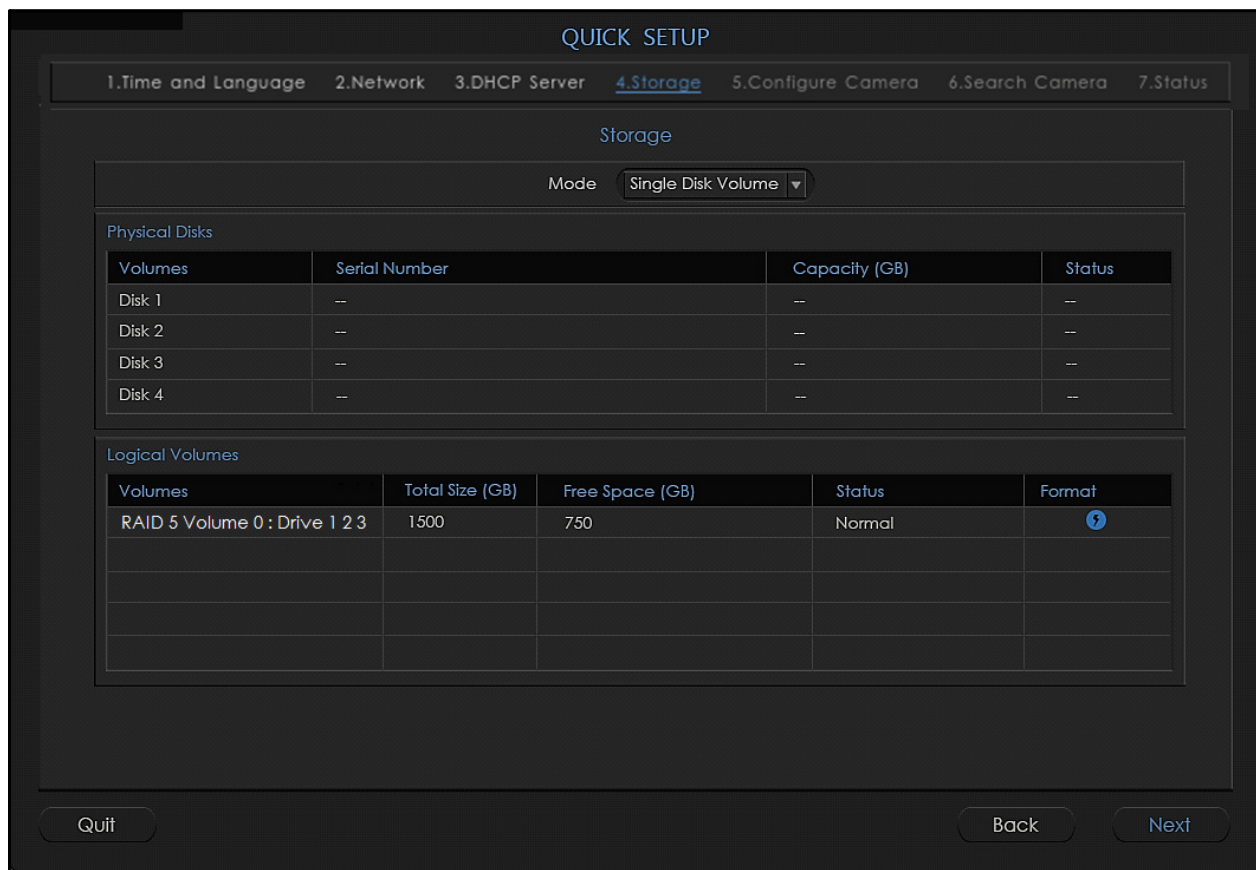

The SATATYA NVR/ NVRX P2 provides different modes for storage management. Select the desired mode of storage from the **Mode** drop-down list — Single Disk Volume, RAID 0, RAID 1, RAID 5, RAID 10.

 *The RAID options will be visible as supported by your variant.*

The **Physical Disks** section displays — Serial Number, Capacity and Status of the connected disks.

The **Logical Volumes** section displays — Volume (Mode along with the Disk Number), Total Space, Free Space,

Status and Format options of the connected disks. Click **Format**  of the desired disk if you wish to format it.

HDD Group

In NVR9608X P2, you can group the HDDs and allocate cameras to these groups.

The **HDD Group** displays the maximum number of Hard Disks installed in the system.

Select Volume displays the disks/RAID automatically. This is dependent on the **Mode** selected in the **Storage** tab.

Select Cameras displays all the cameras connected to the system.

You can create HDD Groups in which you can assign cameras to the desired Volumes. The recordings of these selected cameras will be stored in the selected Volumes.

For Example,

Under **Storage** tab, the **Mode** selected is Single Disk Volume.

Then, under **HDD Group** tab, all the disks will appear individually as per the number of HDDs connected.

Whereas, if the **Mode** is selected as RAID 0/1/5/10, then all the disks will appear as Logical Volumes according to the configured RAID. The maximum number of supported disks is 8.

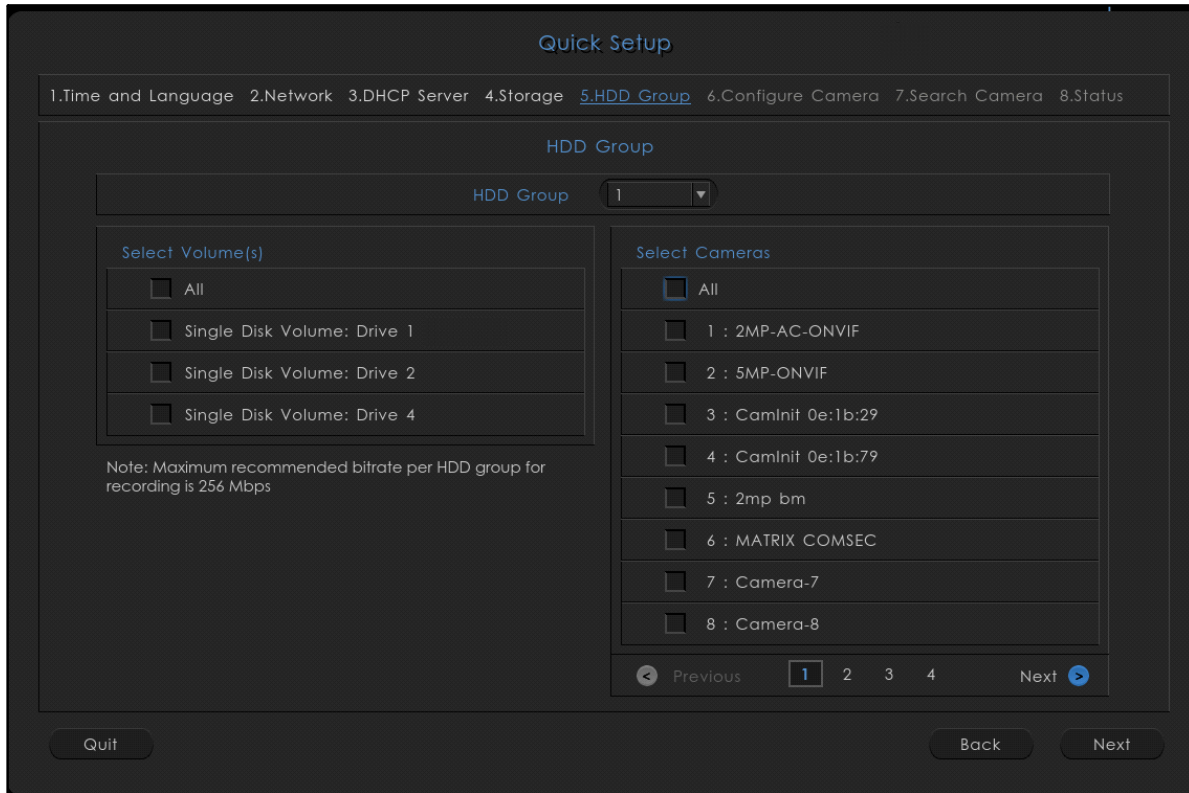

Configure the HDD Group parameters as per your requirement:

HDD Group: Select the desired HDD Group from the drop-down list to which you wish to allocate HDDs displayed under Select Volume(s).

Select Volume(s): Select the check boxes of the desired Volume(s) to be allocated to the selected HDD Group. For Example, HDD Group 1 can have Disk 1 and Disk 2, Group 2 can have Disk 3, Disk 4 and Disk 5 and so on. The Group number will be displayed once the disks are allocated to a group.

Select Cameras: Select the check boxes of the desired cameras that you wish to allocate to the Volumes assigned to the selected HDD Group. The recording of the selected cameras will be stored in the Volumes assigned to the selected HDD Group. The Group number will be displayed once the cameras are allocated to a group.

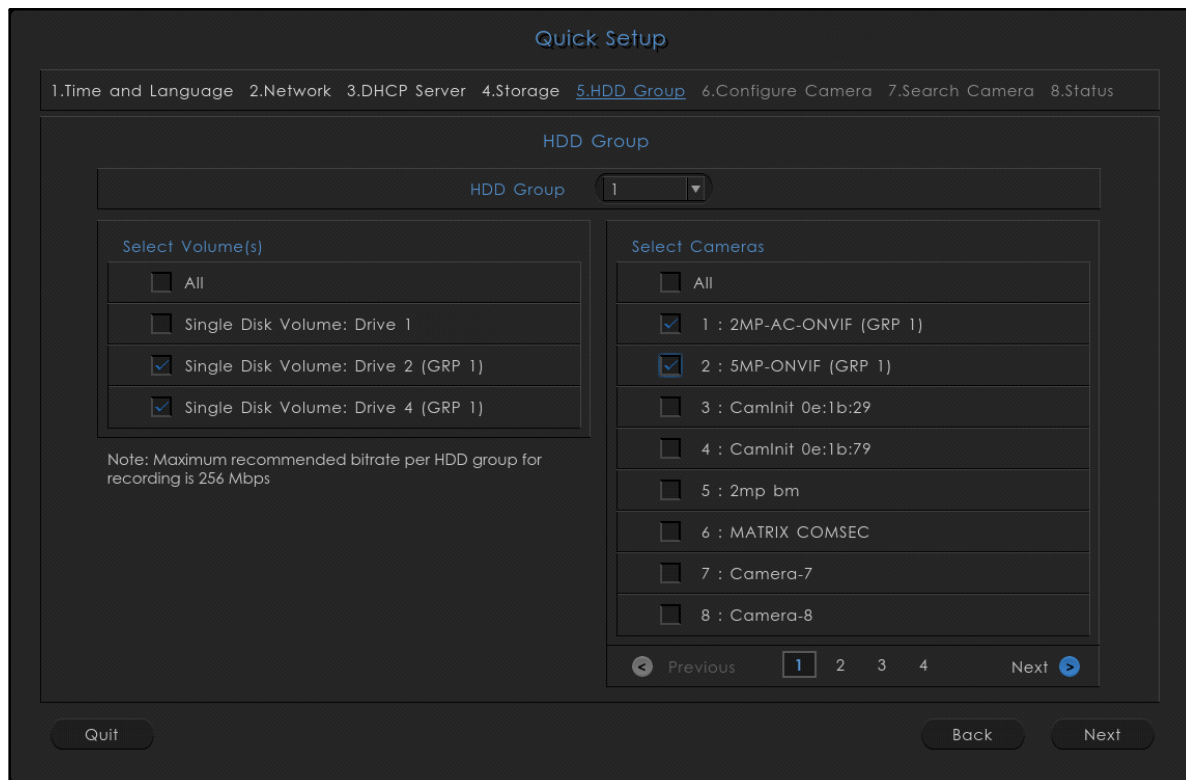

One Volume can be allocated to any one of the HDD Groups. Similarly, one camera can be allocated to any one of the Volume within a HDD Group. When a Volume which is already allocated to a group is selected to be allocated to other group, the following pop-up appears.

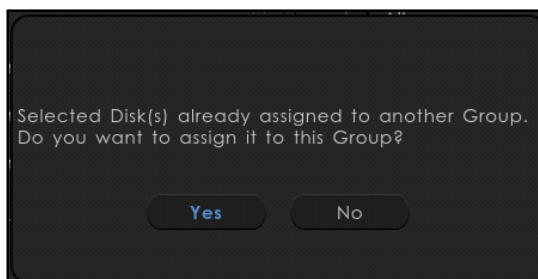

Click **Yes** to move the Volume to the selected group or click **No** to discard.

Similarly, when a camera which is already allocated to a group is selected to be allocated to other group, the following pop-up appears.

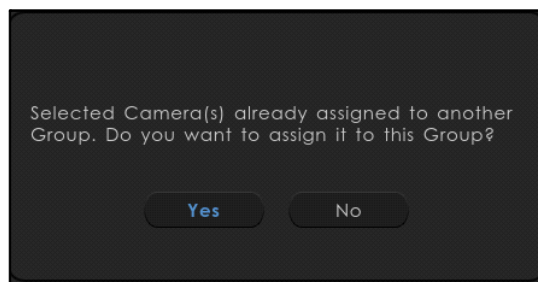

Click **Yes** to move the camera to the selected group or click **No** to discard.

Click **Save** to save the configuration. All the ongoing recording will stop and will resume as per the new HDD Group configuration.



It is recommended that the total bitrate of all the cameras in a HDD Group should be 256 Mbps for optimum performance.

Configure Camera

This page allows the user to configure the parameters for the cameras to be added in the NVRX/ NVRX P2.

Quick Setup

1. Time and Language 2. Network 3. DHCP Server 4. Storage 5. Configure Camera 6. Search Camera 7. Status

Configure Camera

Retain Same IP Address

Start IP Address 192.168.1.126 Username admin

End IP Address 192.168.1.255 Password ***** (Max 20 chars)

Retain Camera Default Profile

Main Stream

Video Encoding	H264	⊞
Frame Rate	59	⊞
Resolution	1280x720	⊞
Bit Rate Type	<input checked="" type="radio"/> CBR <input type="radio"/> VBR	
Bit Rate	2048 kbps	⊞
Quality	4	⊞
GOP	50 (1-100)	
Audio	<input type="checkbox"/>	

Sub Stream

Video Encoding	Motion JPEG	⊞
Frame Rate	55	⊞
Resolution	704x576	⊞
Bit Rate Type	<input checked="" type="radio"/> CBR <input type="radio"/> VBR	
Bit Rate	1024 kbps	⊞
Quality	4	⊞
GOP	50 (1-100)	
Audio	<input type="checkbox"/>	

Quit Back Next

- **Retain same IP Address:** Select this check box, if you wish to add the searched cameras with the same searched IP Address in NVRX. Clear this check box, if you wish to define the range of IP Addresses that are to be assigned to the searched cameras. All the cameras will be assigned IP address within this defined range. For this you must configure the **Start IP Address** and **End IP Address**.
- **Start/End IP Address:** Define a range, that in Start IP Address and End IP Address within which the searched cameras must be assigned IP Addresses.
- **User Name/Password:** Enter the username and password of your choice with which the camera is to be added to the device.
- **Retain Camera Default Profile:** Select the check box if you wish to autostart the Live Stream of the cameras with their default profiles. Clear the check box if you wish to set the Main Stream and Sub Stream parameters as per your choice.

Main Stream and Sub Stream

This option enables the user to set the streaming parameters for the defined cameras. Configure the parameters for the Main Stream and Sub Stream as follows:

Video Encoding: Click the picklist and click again to select the desired Video Encoding option.

Frame Rate: Click the picklist and double-click to select the desired Frame Rate. The range of frame rate that can be set for a camera is 1 to 30, for cameras added via Brand-Model and Camera Initiation. In NVRX/NVRX/NVRX P2 when cameras are added via ONVIF, the range of frame rate that can be set is 1 to 64. The range for cameras added via ONVIF will differ. It will depend on the frame rate range supported by the camera.



2MP Ruggedized cameras with firmware IPCamera_S05_FirmwareV03R01 and later support Frame Rate range 1 to 60, added via any method. This is applicable for NVRX/NVRX P2 series only.

Resolution: Click the picklist and click again to select the desired Resolution option.



The stream resolution of selected IP Camera will display in the Resolution list. In case if the user has configured the ROI (Region Of Interest) into the running stream profile of IP Camera then, the Stream resolution of that particular stream will display into the resolution list.

The custom resolution of minimum 64pixels and maximum 8192pixels can be played into the Live View.

The VGA resolution, that is 640x480 is supported in all Matrix Cameras supported by NVR/NVRX, except the following:

- SATATYA CIBR13FL40CW
- SATATYA CIDR13FL40CW
- SATATYA CIDRP20VL130CW
- SATATYA CIBR30FL36CG
- SATATYA CIBR30FL60CG
- SATATYA CIDR30FL36CW
- SATATYA CIDR30FL60CW

Bit Rate Type: Click the desired radio button — Constant Bit Rate (CBR) or Variable Bit Rate (VBR).

Bit Rate: Click the picklist and click again to select the desired Bit Rate option.

Quality: Click the picklist and click again to select the desired Quality option. Selecting higher settings will give you higher quality video, at the expense of network bandwidth and disk storage capacity.

GOP: Configure the desired GOP from 1 to 100.

Audio: Select this check box if you wish to enable Audio in synchronization with the video for the stream type of selected camera. Clear to disable.



Audio will function only if supported by the camera.

Search Camera

As per the configuration of the LAN parameter, the cameras in the network will be displayed with the following details — IP Address, HTTP Port, Brand Name, Model Name, ONVIF (that is added via ONVIF, then check box will be selected), ONVIF Port, Add and Test — on this page.

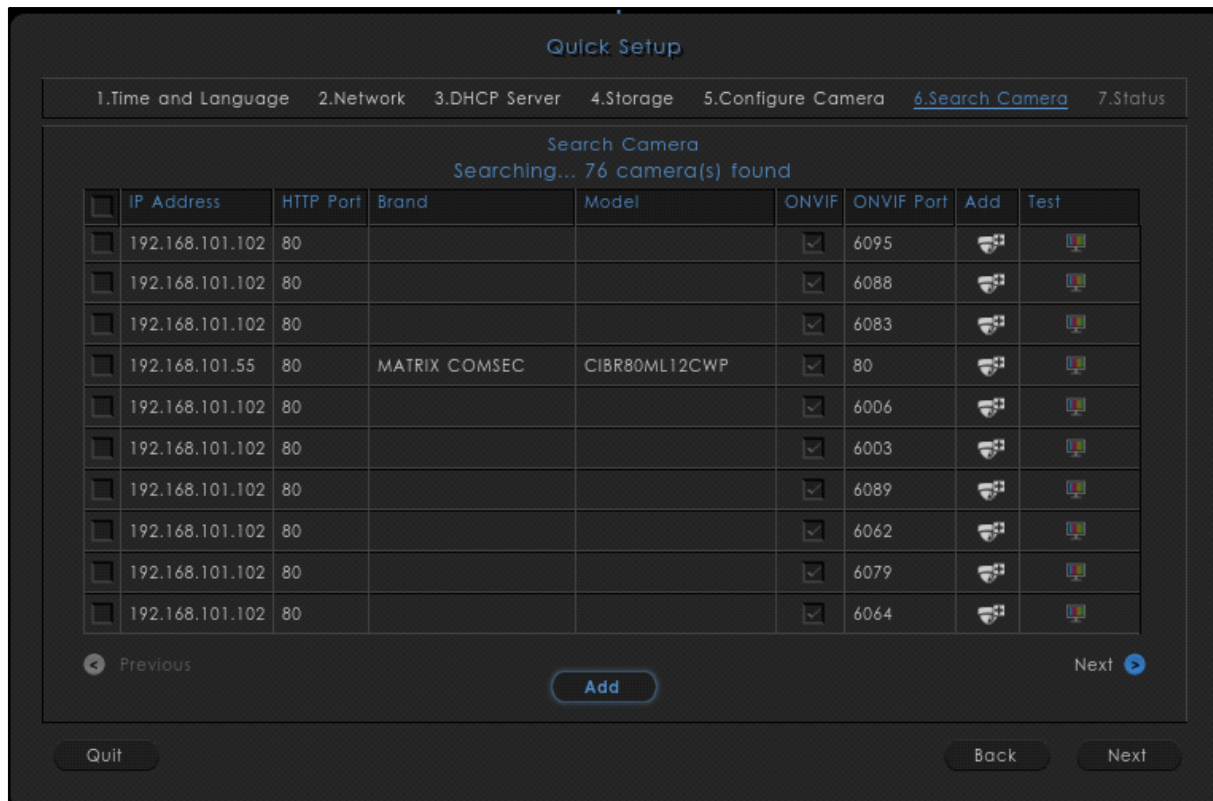

If the Camera is already added, then the **Add** column will show status as added with symbol . There will be **Test** button against the added camera that is enabled. Click on the Test button to test the Camera.

If the Camera is not added, then click on **Add** button to add the Cameras. Then you can click on the Test button to test the Camera.

If the Cameras are not added and if you wish to auto configure all these cameras, then select the check boxes of the desired cameras and click **Add** button.

Status

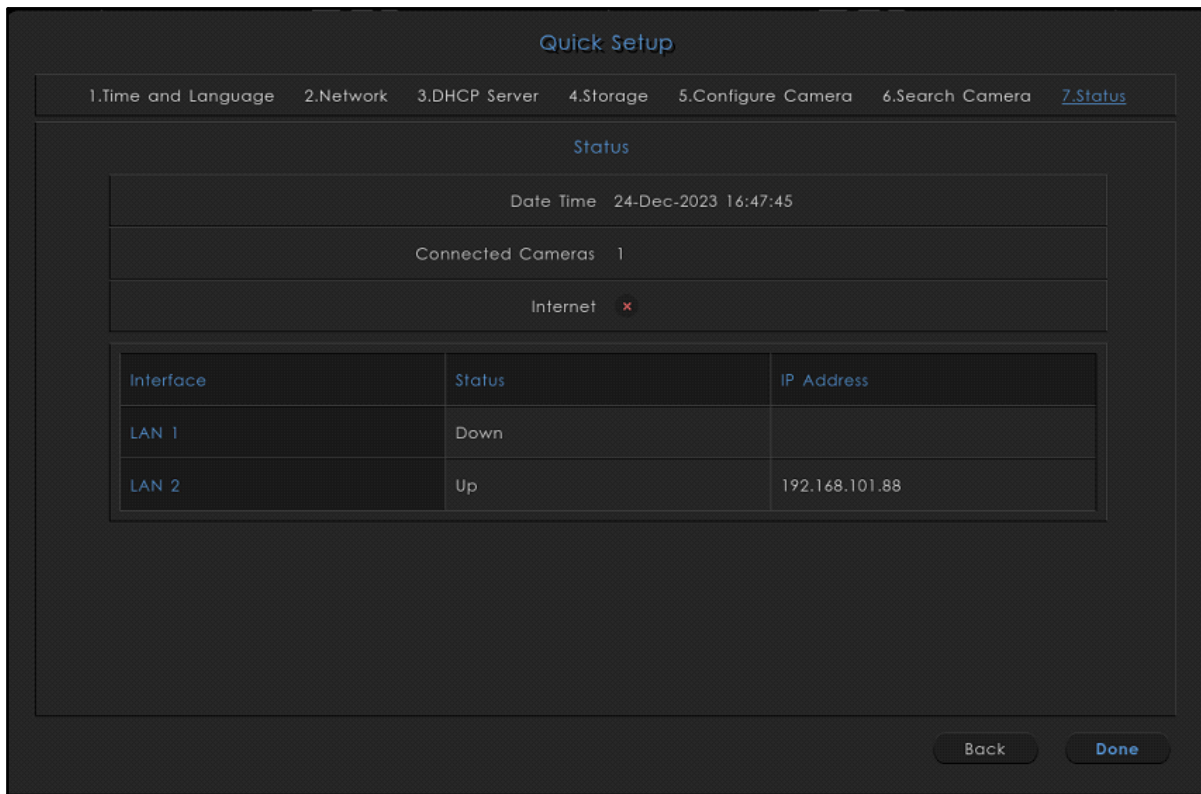

The following details are displayed — Date and Time, Connected Cameras and Internet connectivity.

Interface section displays the connected LAN and its status with assigned IP Address.

Click **Done** to complete the setup or **Back** button to re-configure the previous parameters.

Once all parameters are configured you can also switch to the particular parameter to be re-configured by clicking on to the respective tab.

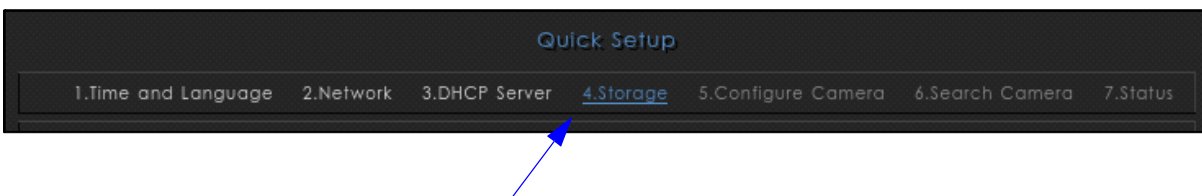

Local configuration of the SATATYA Device

This chapter explains the functionalities which can be configured from the SATATYA Device using the various interface options.

All options for monitoring and control of the NVR/NVRX/NVRX P2/HVR functionalities are available from the Toolbar. Hover the mouse at the bottom of the monitor screen to invoke the Toolbar.

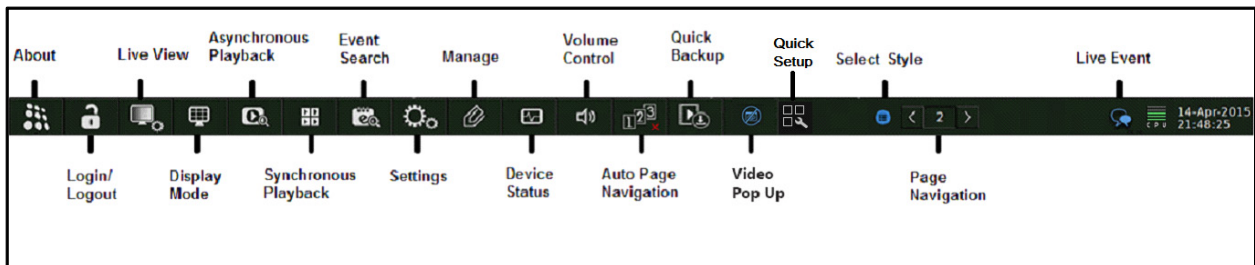

Click **Settings**, the following menu interface appears.



The next section explains each of the device configuration and monitoring options in detail to enable the user to make optimum use of the SATATYA device.

About

This option enables the user to view details of the product, Firmware Build Date-Time as well as its version. Click on **About** option in located on the toolbar to view the details. The details is shown as below:

Firmware Version V8R6 and onwards.



Firmware Version V8R1 to V8R6.

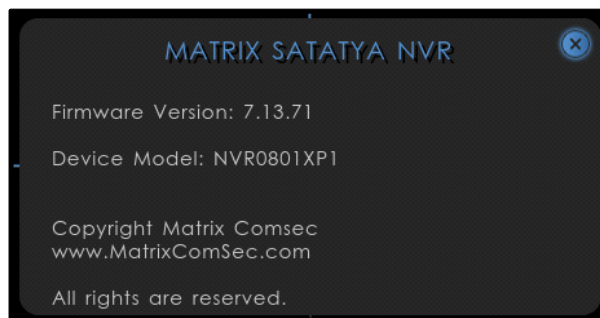

For version earlier than V8R1, in Device Model, P1/P2 will not be visible.

Navigation using Remote control

Press the **Toolbar** button of the remote control to directly load the menu list over the toolbar. Navigate to the **About** option using the arrow keys. Press the **Enter** button once the option is highlighted and then the **About** window appears which shows the details of the SATATYA device. Now, click on Cancel button on the remote control to close the window.

Live View

This functionality allows the user to configure the settings related to **Main** and **Spot** display, such as VGA and HDMI resolution, layout style, default layout, sequencing interval etc. There are two live view setting options:

- **Display Settings**
- **Appearance Settings**



VGA is not supported in NVRX/NVRX P2 series.

Display Settings

In order to access this functionality, click on the **Live View** icon on the toolbar, the page appears as shown below:

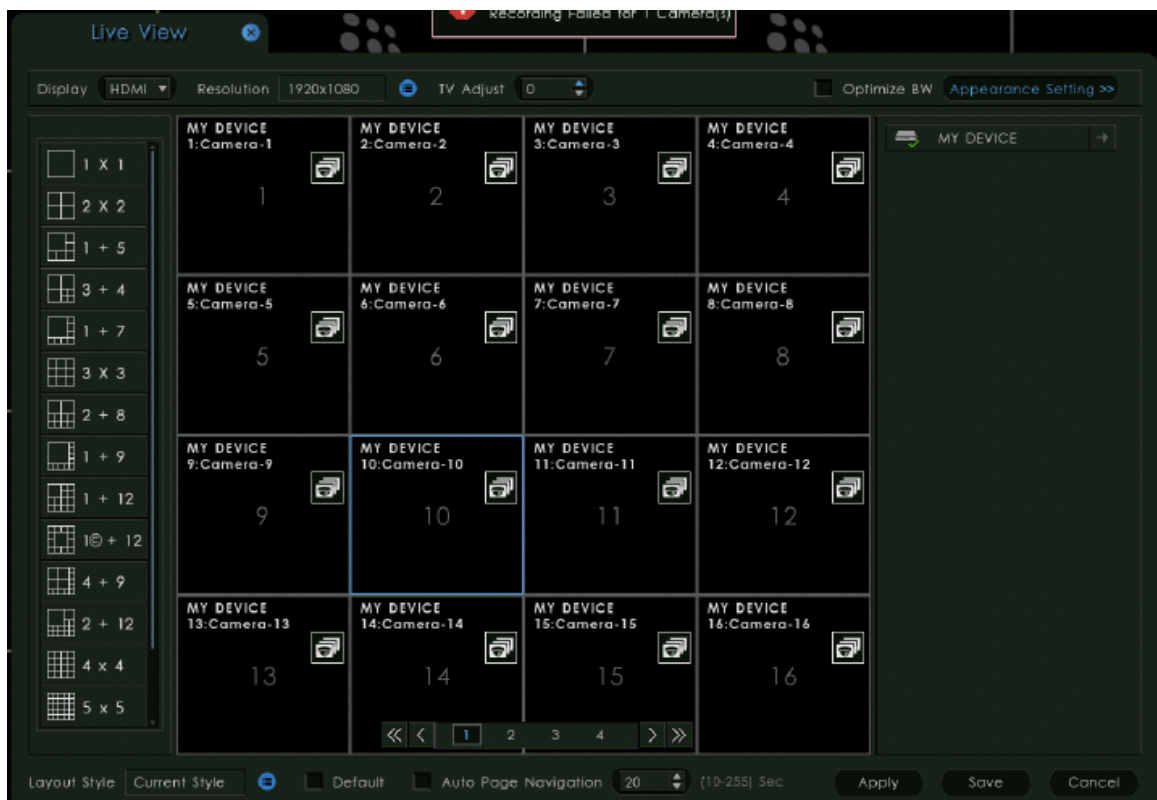

The page displays the list of cameras in the right pane and different layout templates in the left pane.

The camera list contains only those cameras whose access rights are given to the user. **E.g.:** If an admin creates a user named Jerry and gives him the access rights of four cameras from **Device Configuration > Configuration Settings > User Account Management > User Account** page. Then, only four cameras will be visible for Jerry. If the admin changes user rights in the running session, then it will take effect in the next time login only.

Select the **Live View** type from the options of **Real-time** or **Smooth**.



Real-time or Smooth options for Live View are applicable for NVRX/NVRX P2 series only.

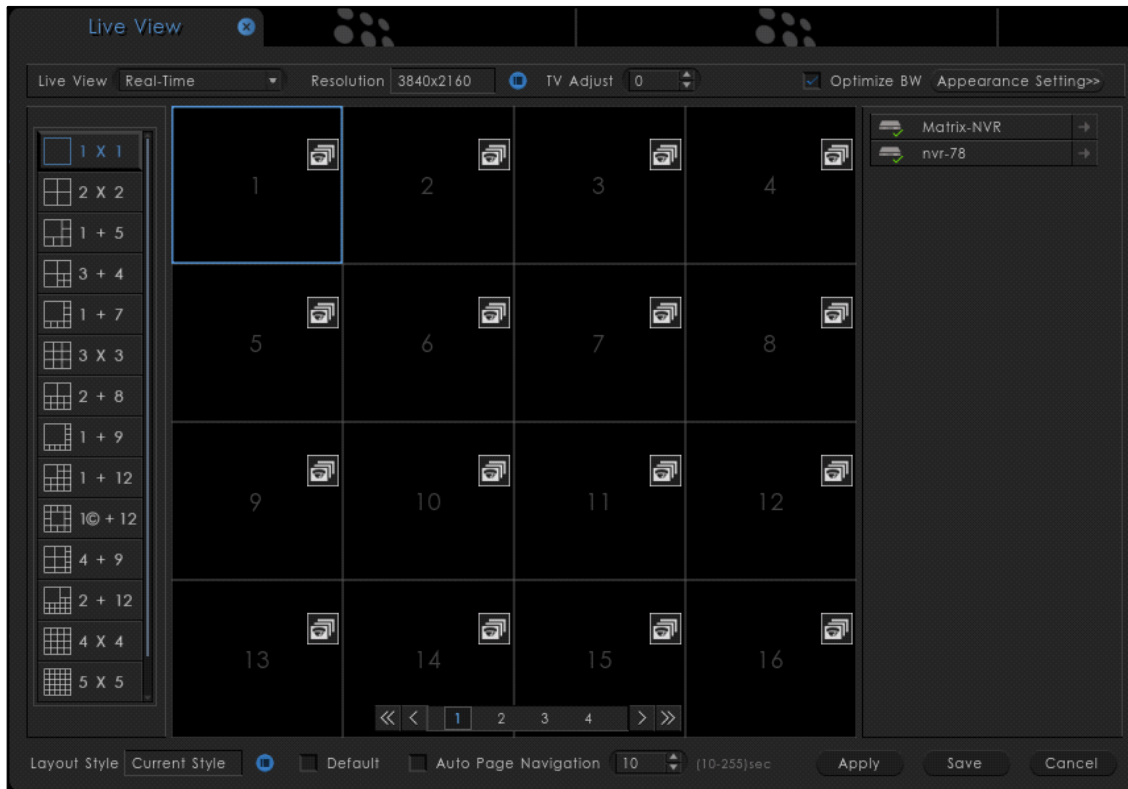

Real-Time: Select this option to view the live view in real time. If you select this option, you might observe glitches in the live view.

Smooth: Select this option to view the live view with minimum glitches which may occur due to network issues.

Select the display type from the options of **Main** or **Spot**. If **Main** display is selected, then select the desired resolution from the **Resolution** list:

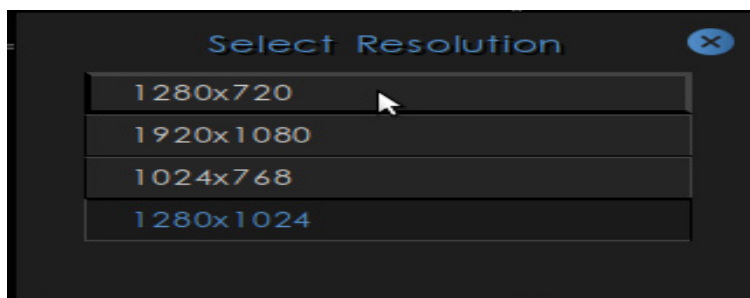

If **Spot** display is selected, then select the TV Adjust value by scrolling the arrows. The values can be between 0 to 3. This enables to adjust the display view on the spot monitor within the display screen.



*In NVRX and NVRX P2 series variants, only **HDMI Main Display** type is supported. You can also select the resolution and TV Adjust value for the same.*

Resolution in NVRX Variants

SATATYA NVRX/NVRX P2 Series variants supports the Resolutions as shown in the list below:

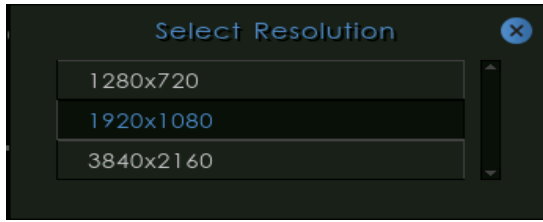

After resolution is changed, the system will restart to apply the new changes.

Bandwidth Optimization

Optimize BW: This option is enabled by default. This means, when you select a layout in such a way that it contains more than 16 windows i.e. 5X5, 6X6 or 8X8 window (**8X8 window is not applicable for NVRX P2 series**) then sub stream will be applied in all the windows if this check box is enabled.

Bandwidth Optimization in NVRX/NVRX P2 variants

In NVRX/NVRX P2 series variants, sub stream will be applied when you select a layout containing more than 1 window E.g. 1X1 window.

Appearance Settings



Appearance Settings are not applicable to NVRX P2 series.

Click on **Appearance Settings** option and the following page appears as shown below:



Display: Select the Display type from the drop-down list. The options available will depend on the device variant.

- **Hue:** Specify the hue value ranging between 0-100 by using the slider.
- **Saturation:** Specify the Saturation value ranging between 0-100 by using the slider.
- **Brightness:** Specify the Brightness value ranging between 0-100 by using the slider.
- **Contrast:** Specify the Contrast value ranging between 0-100 by using the slider.

Click on **Save** to save the settings.

Layout Style: This field contain a particular layout format (of monitoring windows) from the total predefined layout templates. The user also can define upto 5 layout styles.

In Local Client, user will get the default layout styles already stored according to the SATATYA device variant shown below.:

Layout Style/ SATATYA devices	Style 1	Style 2	Style 3	Style 4	Style 5
All HVR & NVR Variants except NVR 64	4 x 4	2 x 2	3 x 3	1 x 1	1 + 5
NVR 64	2 x 2	1 x 1	2 x 2	1 x 1	2 x 2
NVRX variants	4 x 4	1 x 1	2 x 2	3 x 3	5 x 5
NVRX P2/NVRXS P2 variants	1 x 1	2 x 2	3 x 3	4 x 4	5 X 5

Default: It is also possible to set the configured layout style as default layout for Main and Spot output display by enabling the **Default** checkbox against the layout style.

Auto Page Navigation

This option enables the user to start and stop viewing the cameras in a sequential pattern depending on the layout template selected for displaying the live video of the cameras.

You can configure sequencing for a layout style by enabling the **Auto Page Navigation** checkbox for that particular layout style.

Specify the **Navigation Interval** in seconds which will be maintained while displaying two consecutive set of cameras while sequencing. The range to set the Auto Page Navigation interval is 10 - 255 seconds.

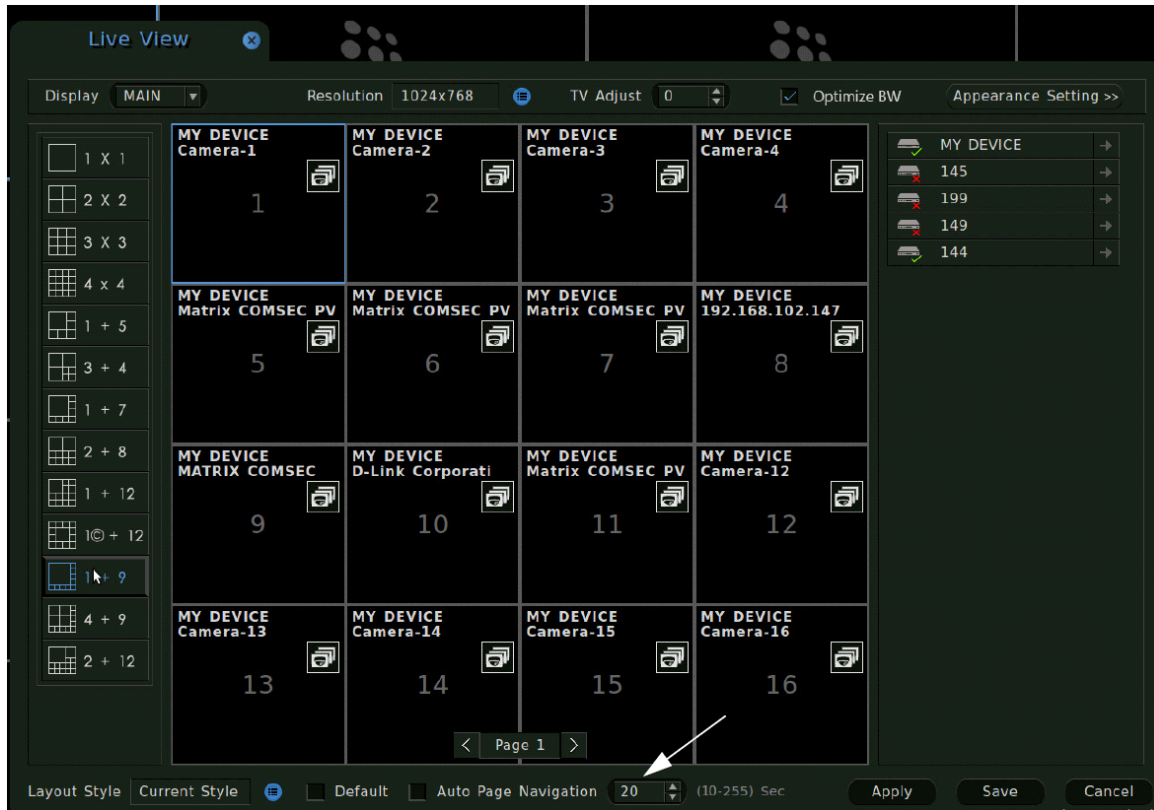

Clicking on **Apply** button will reflect the configured layout style on the display and will start sequencing for it if enabled.

Start Auto Page Navigation Automatically

You can also start the auto page navigation automatically on the device boot up without any human intervention. To do so, follow the below steps:

- Select the required Layout style
- Make that style as Default.
- Enable Auto Page Navigation option
- Save your configuration.

Now on the Device boot up, auto page navigation will start automatically for the selected default layout style.

You can also Enable/Disable Auto Page Navigation from the toolbar itself. Single click on the option **Auto Page Navigation** as shown below, the device will start/stop displaying the cameras in a sequential order.



Window wise Sequencing

To configure the window wise sequencing select the window (window 1as below) where sequence is to be configured and click on **Configure** button as shown with the arrow below:

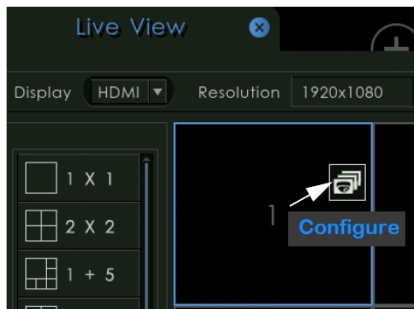

The selected window i.e. here Window 1 will appear for configuring the cameras.

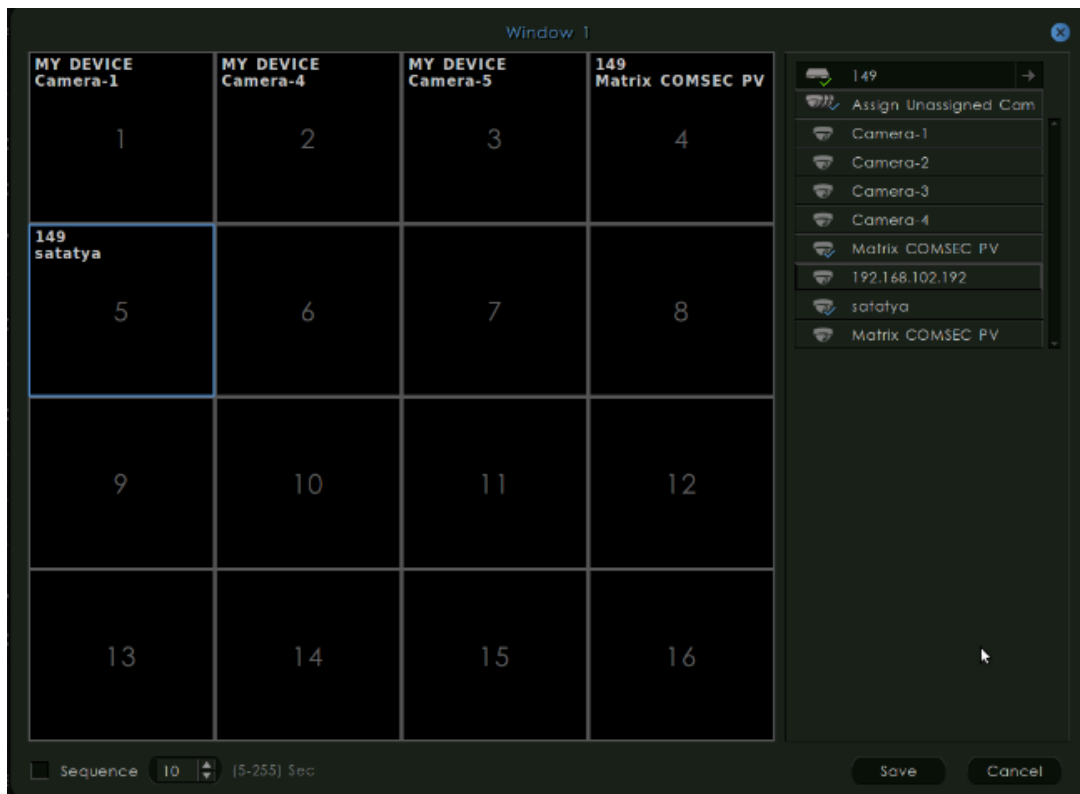

Now from the device list on right side select the desired cameras of the device and assign to the windows. The assigned cameras will run in a sequence of live view.

Click on **Save** button to commit the changes. After the cameras are assigned to the window sequencing the configure symbol changes as shown below.

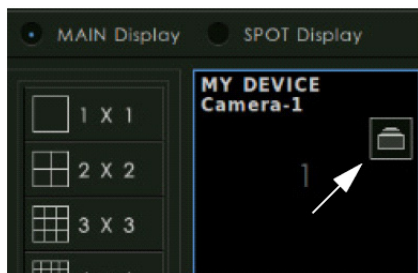

Now click on **Apply**. The camera sequencing will start on the monitor in the configured window (here window1) provided the sequencing checkbox is enabled. Also you can start the sequence from the live toolbar by clicking **Start Sequencing**.



Assume that some camera audio is ON; now when window sequencing is configured at any window, then in window sequencing audio will not be turned ON. Now if in window sequencing that particular camera is in view and if user stops sequencing, then the camera audio will not get resumed again. The user has to manually start the audio in this case.

From the live toolbar click **Expand** to view the assigned cameras on different windows. To view cameras in a single window click **Collapse**  button from the toolbar.

View Cameras

This option allows the user to view the cameras connected to the SATATYA device. Also it will display the list of other network devices added to the SATATYA device and their cameras. To access this functionality, click on **Add Cameras**  option from the window as shown:

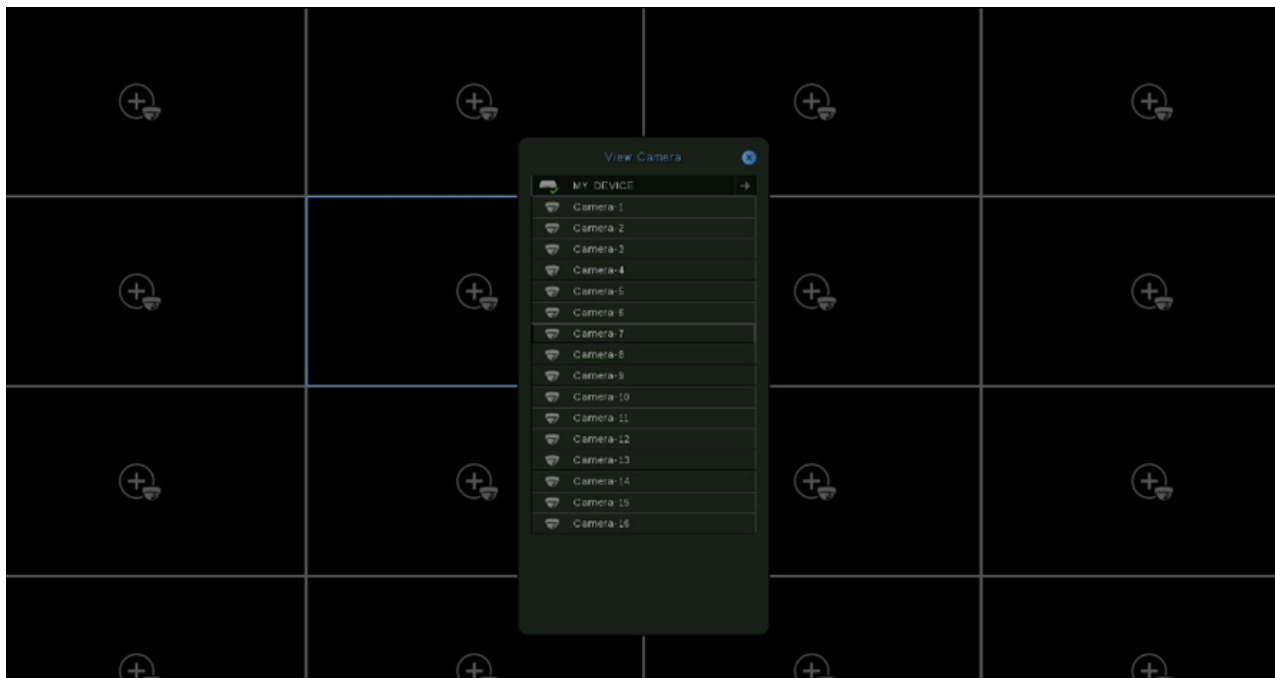

The list of cameras displayed enables the user to view the live stream of any camera by single left clicking on the desired camera. Select the Camera from the list.

Whenever user tries to add a camera in a monitoring window for the live view and the maximum decoding limit to run the video stream has been reached (already) then, the user will be notified by the  **Decoding Error**. This will display on the window of respective cameras for which the stream can not be played.



As per the parameters; Resolution, Frame per Second (fps) configured in the current stream profile, the decoder will be occupied to decode the video stream. User can try by changing such parameters with their lower values configured in the current stream profile of the live monitoring camera's to utilize the decoding capacity of the cameras in the so that more number of cameras can be added for the live view or reduce the number of live / playback camera's.



The camera list contains only those cameras whose access rights are given to the user.

If the admin changes user rights in the running session, then it will take effect in the next time login only.

The live view of the camera will start in the selected monitoring window.

Right click inside the window of the selected camera to perform the following action:

- PTZ Control
- Snapshot
- Zoom
- Start/Stop Manual Recording
- Start Audio
- Speak Now
- Instant Playback
- Start Sequencing
- Expand
- Close



For NVRXS P2 series, Speak Now will not be accessible from the Local Client. However you can use the same from Device Client.

User can perform “Digital zoom” after clicking the **Zoom** button. For details [See “Digital zoom” on page 217.](#)

Display Mode

This option enables the user to toggle between the various predefined layout templates on the system. It allows the user to select any one template at a time on the live view mode to view single or multiple cameras simultaneously. To access this functionality, click on **Display Mode** option on the toolbar. The page appears as shown:



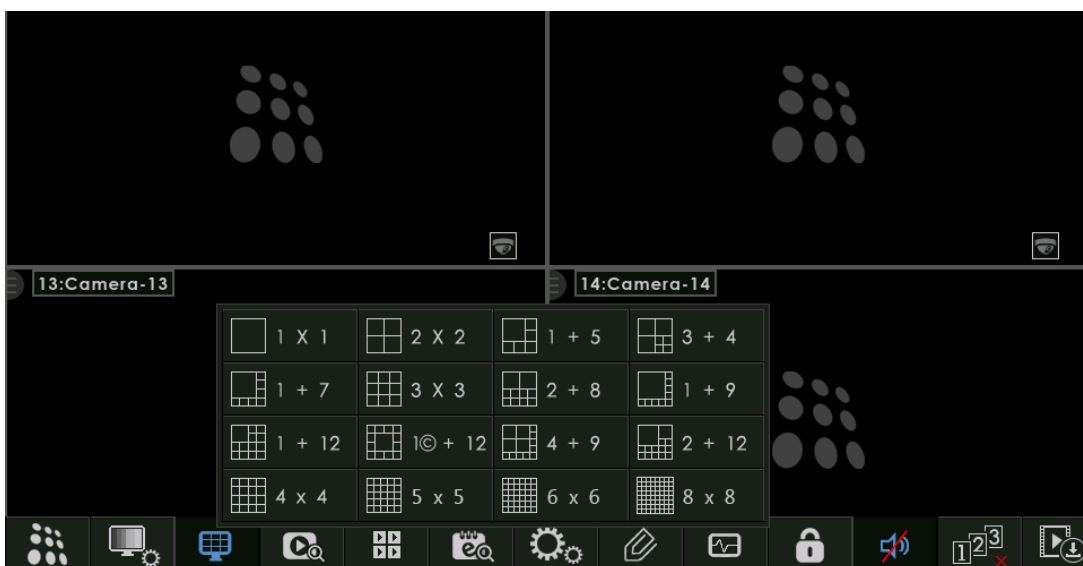

NVRX/NVRX P2 Display Modes

In NVRX/NVRX P2 series variants, 16 layouts are supported as shown in the screenshot below.



Click on any of the layout templates shown above based on the cameras to be viewed simultaneously and then assign a unique camera number to each monitoring window of the selected layout template based on the requirement.

Playback Search

This option enables the user to search for previously recorded files with the option to filter the search as per the desired time period and playback the recorded video. In order to access this functionality, click on the  icon on the toolbar for Asynchronous playback and  icon for synchronous playback.

For Asynchronous Playback [See “Asynchronous Playback- Local” on page 153.](#)

For Synchronous Playback [See “Synchronous Playback- Local” on page 155.](#)

Event Search

The Matrix SATATYA HVR/NVR/NVRX/NVRX P2 has the capability to store and display event logs. The system has the capacity to store up to 10000 events. The following types of event logs are generated by the system:

- All Events
- Camera events
- Sensor events
- Alarm Events
- System Events
- Storage Events
- Network Events
- Other Events
- User Events
- Cossec Events
- Image Upload Events



Alarm Events and Sensor Events are not applicable to NVRXS P2 Series.

The maximum logs displayed as per the set Date/Type filter is 2000. If the set Date filter has more than 2000 records, the same will not be displayed. Hence, set the Date filter carefully.

On selecting the **Event Search** option from the toolbar, the following page appears:

Index	Date Time	Event Type	Event	State	Source	Advance Details	Play
1	09/02/2024 12:18:38	User	Configuration	Change	LAN 1	admin Local Client	
2	09/02/2024 12:18:35	User	Configuration	Change	LAN 2	admin Local Client	
3	09/02/2024 12:18:28	User	Configuration	Change	LAN 1	admin Local Client	
4	09/02/2024 12:18:23	User	Configuration	Change	LAN 2	admin Local Client	
5	09/02/2024 12:17:55	User	Configuration	Change	LAN 1	admin Local Client	
6	09/02/2024 12:17:32	User	Configuration	Change	LAN 2	admin Local Client	
7	09/02/2024 12:17:29	User	Configuration	Change	LAN 1	admin Local Client	
8	09/02/2024 12:17:25	User	Configuration	Change	DHCP Server	admin Local Client	
9	09/02/2024 12:17:22	User	Configuration	Change	LAN 1	admin Local Client	
10	09/02/2024 12:17:20	User	Configuration	Change	Date & Time	admin Local Client	
11	09/02/2024 12:08:47	User	Configuration	Change	LAN 2	admin Local Client	
12	09/02/2024 12:08:43	User	Configuration	Change	LAN 1	admin Local Client	
13	09/02/2024 12:08:40	User	Configuration	Change	HDD	admin Local Client	
14	09/02/2024 12:00:16	User	Configuration	Change	HDD	admin Local Client	

The search criteria provides a Time and Event Type based filter to view the relevant Event Logs.

Select the device from the **Devices** list.

Select the **Start Date** using the calendar button to specify the Start Date from which Event Log is to be generated.

In **Start Time**, click each option — HH, MM— and then select the desired value from the drop-down list to specify the Start Time from which Event Log is to be generated.

Select the **End Date** using the calendar button to specify the End Date till which Event Log is to be generated.

In **End Time**, click each option — HH, MM— and then select the desired value from the drop-down list to specify the End Time till which Event Log is to be generated.



The Start Time and End Time can be selected by clicking the up and down arrow buttons for all variants other than NVR/NVRX P2 series.

Select the Event **Type** from the drop-down list.

Click the **Search** button.

The relevant event logs fulfilling the filter criteria will be displayed in the **Event List** Grid. Use the scroll bar to navigate through the list. Only 2000 Event Logs will be displayed on the page.

Click **Play** if you wish to view the playback.



The latest occurred events, falling under the search criteria entered in the filter will be displayed on the top of the page.

Settings

This functionality enables the user to configure all the parameters of the system necessary for proper operation of the system. This options consists of various sub-options as follows:

- Basic Settings
- Camera Settings
- Network Settings
- Storage and Backup Settings
- Device I/O Settings
- User Account Management
- Event and Action Settings
- Maintenance
- Devices

To access this functionality in local configuration, click on **Settings** option located on the toolbar. The page appears as shown below:



Select the desired device whose settings are to be modified from the **Devices** list.

For all the settings, refer Device Client part of the manual for detailed explanation. See ["Device Configuration" on page 223](#).

Manage

This option enables the user to perform the following functions:

- Activate/Deactivate Manual Trigger
- Activate/Deactivate Outputs
- Change Password
- View online users
- Block/Unblock users
- Restart or shutdown the device
- Default parameters
- Password Recovery



*The **Password Recovery** tab is applicable for NVRX/NVRX P2 series only.*

In order to access this functionality, click on the **Manage** button on the toolbar. The page appears as shown:



Select the desired device whose Manage option is to be viewed from the **Device** field.

Users

This option enables to view online users as well as block some of the online users as and when required. The user can also unblock the previously blocked users.

Select the Online User option. The following page appears:

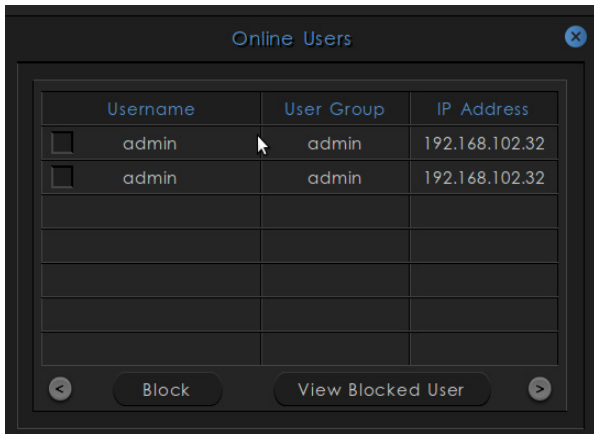

Select the logged in users to be blocked by checking the boxes against the relevant entries in the list and click on the **Block** button. Only admin user can block the other users such as operators, viewers.

Click on the **View Blocked Users** button to view the currently blocked users. Select the users to unblock by checking the boxes against the relevant entries in the list and click on the **Unblock** button.

Alarm Output



Alarm Output is not applicable to NVRXS P2 Series.

The **Alarm Output** option enables the user to manually activate or deactivate the relay output as and when required. On selecting this option the following page appears. The availability of number of alarm output ports will depend on the device variant.

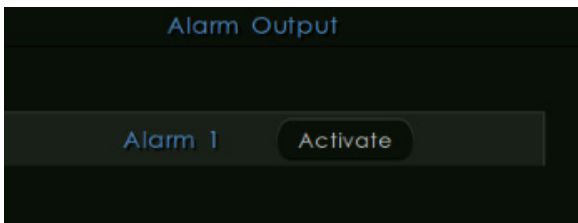

The button toggles between **Activate** and **Deactivate** based on the current status of the output as shown.

System Control

This option enables the user to activate/deactivate **Manual Trigger**, control the **System** and **default** the parameters such as Network, User Account and Configuration. On selecting **System Control** option, the following page appears:



Manual Trigger

The **Activate Manual Trigger** option enables the user to trigger the outputs related to the Manual Trigger event as configured from the **Event and Action** option of the **Settings** page. The button toggles between **Activate** and **Deactivate** based on the current status of the Manual Trigger.

System

The **Shutdown** and **Restart** section enables the user to shutdown and Restart the HVR respectively. Select the relevant option by clicking on the appropriate button. The system prompts for Username and Password. Enter correct Username and Password and click on OK button. The device will Shutdown or Restart as per the option selected. Only the users of the group type **Admin** can perform the task.

Default

The **Default** option allows the user to default the parameters of the device. The system enables the user to default the following parameters by clicking the respective check boxes.

- Network Parameters
- User Account
- Configuration

Enter the correct Username and Password to default the selected parameters. Only the users of the group type **Admin** can perform the task.

Language

This option allows user to change the default language of the system. Click on the **Language** button and choose the required language from the Language drop-down list as shown below:

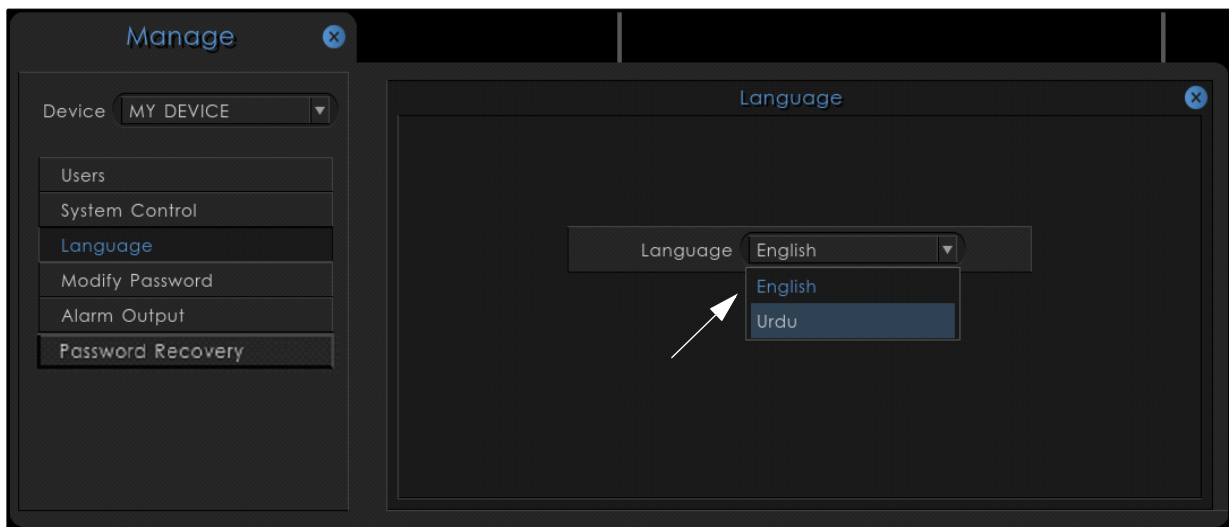

The other Languages except English must be configured first by Admin group users at the Device Client to make them available in Language drop-down list for selection. For the configuration of Language, See [“Language” on page 202.](#)

Once the language is selected, a confirmation pop-up to change the language will display. Click on the **OK** button to change the default language or **No** to cancel the configuration.

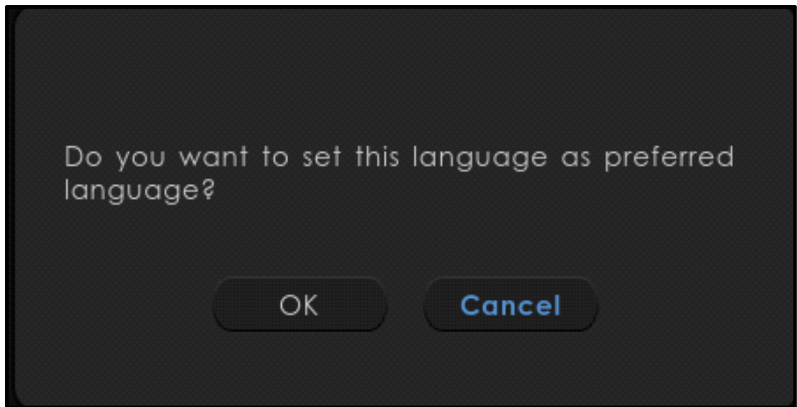

Once the Language is selected but not saved by clicking on OK button, still the changes will be reflected in the local client till the next Login.

The updated language will be reflected in the Device Client after next login.

Modify Password

This option allows the user, who is currently logged in to change the password for accessing the web Jeeves application. On selecting this option, the following page appears.

A dark-themed dialog box titled "Modify Password" with a close button (X) in the top right corner. It contains three stacked input fields: "Old Password", "New Password", and "Confirm Password". Below these fields is a single "OK" button.

Enter the Current Password in the **Old Password** field and then enter a unique password in the **New Password** field. Reenter the new Password in the **Confirm Password** field. Click on the **OK** button to change the Password.

Password Recovery

This option enables the user to configure the Email ID and Security Questions which are used to recover the password. The Email ID/Security Questions can be configured during the first login. But if not done then can be configured now. The Email ID/Security Questions if configured at the time of first login can also be modified now.

On selecting this option, the following page appears.

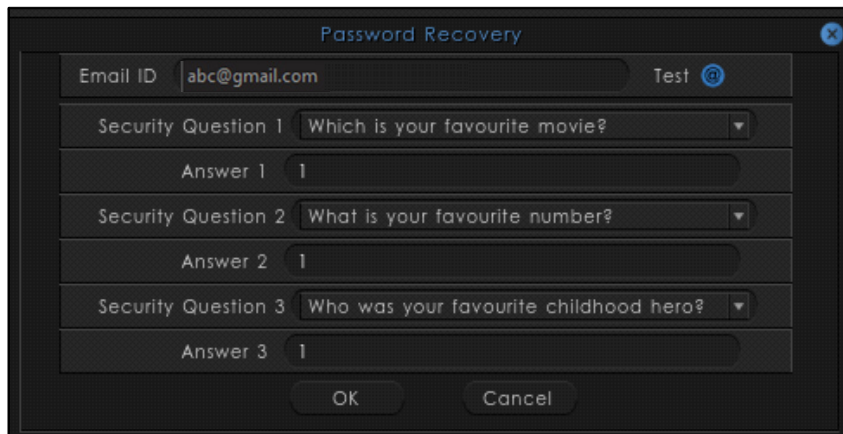

Enter the Email ID through which the password recovery will be done. Click **Test**  to send a test email to the configured Email ID.

Select the desired Security Questions from the drop-down list. Specify the answers for each of them. Click **OK** to save the settings.



*The **Password Recovery** tab is applicable for NVRX/ NVRX P2 series only. Password Recovery is not supported in cascaded devices. For example: Device installed is NVR0801X, now we add a new device NVR64S, then this tab will not be visible.*

Modifications done in the Password Recovery tab will be logged as events under Event Logs.

Device Status

The system status utility enables the user to view the current status of the various functionalities and components as configured from the system. In order to access this functionality, click on the **Device Status** icon on the toolbar, the following page appears:

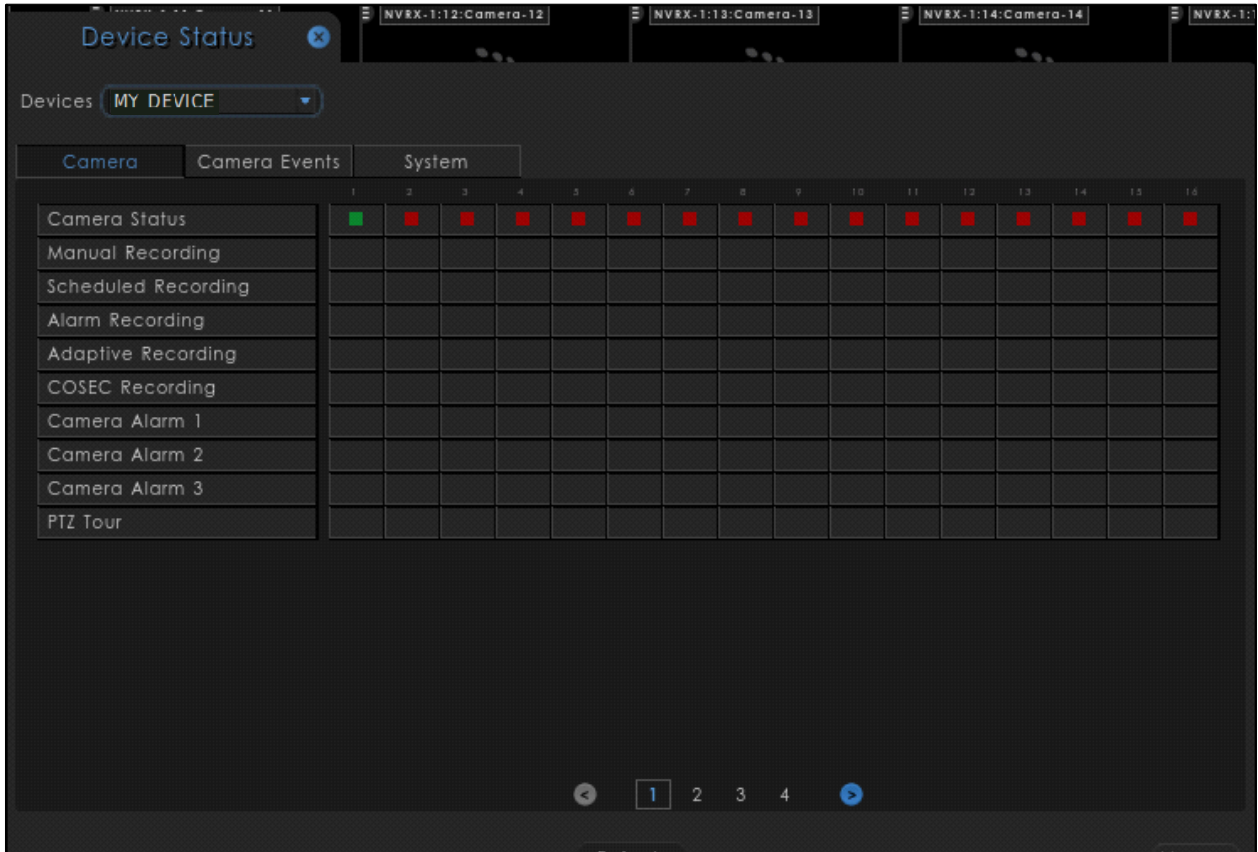

For more details on Device Status, [See "Device Status" on page 194.](#)

Login/Logout

This option allows the user to login or logout from the device. This icon indicates whether the user has logged into the device. In the event of the logged out icon, click on the same to bring up the log in window.

To access the functionality, click on **Login/Logout** icon located on the toolbar. The page appears as shown:

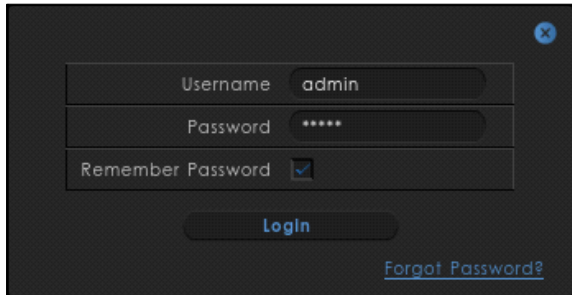

The screenshot shows a dark-themed login form. It contains three input fields: 'Username' with the text 'admin', 'Password' with five asterisks, and 'Remember Password' with a checked checkbox. Below the fields is a 'Login' button and a blue link labeled 'Forgot Password?'. A small blue 'x' icon is visible in the top right corner of the form area.

Enter the correct **Username** and **Password** in the fields provided. Select the **Remember Password** checkbox to allow the device to remember the credentials entered. Click on **Login** button to login into the device.

In case you forgot the password, click **Forgot Password** link. You will be asked to reset your password. For more details, refer to "[Forgot Password- Local Client](#)".



*The **Forgot Password** link is applicable for NVRX/NVRX P2 series only.*

Volume Control

This utility enables the user to control the volume of the audio output/HDMI. Click on **Volume Control** option on the toolbar to access this functionality. The page appears as shown:

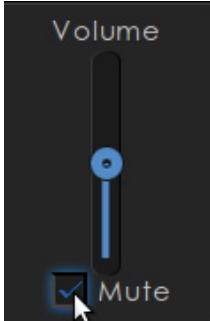

The user can adjust the volume by moving the control up and down as per the requirement. Click on **Mute** checkbox to mute the volume.

Volume Control in NVRX/NVRX P2 Series Variant

Click on **Volume Control** option on the toolbar to access this functionality. The page appears as shown:

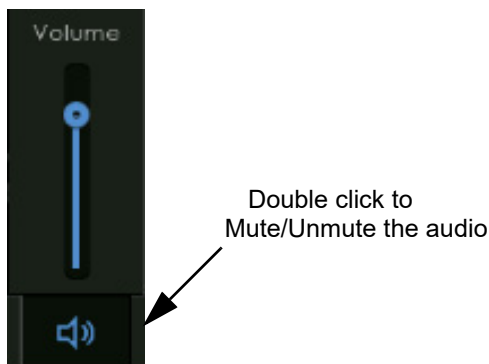

The user can adjust the volume by moving the volume control up and down. You can move the control up-down either by dragging the seek bar over the volume line or by clicking the volume line or by scrolling the mouse.

Double click on the Volume icon to Mute/Unmute the audio.

Quick Backup

Quick Backup is a feature that enables the user to get the backup of the desired camera from the Live View page itself easily and quickly.

To do so, click on **Quick Backup** icon on the toolbar as shown below.

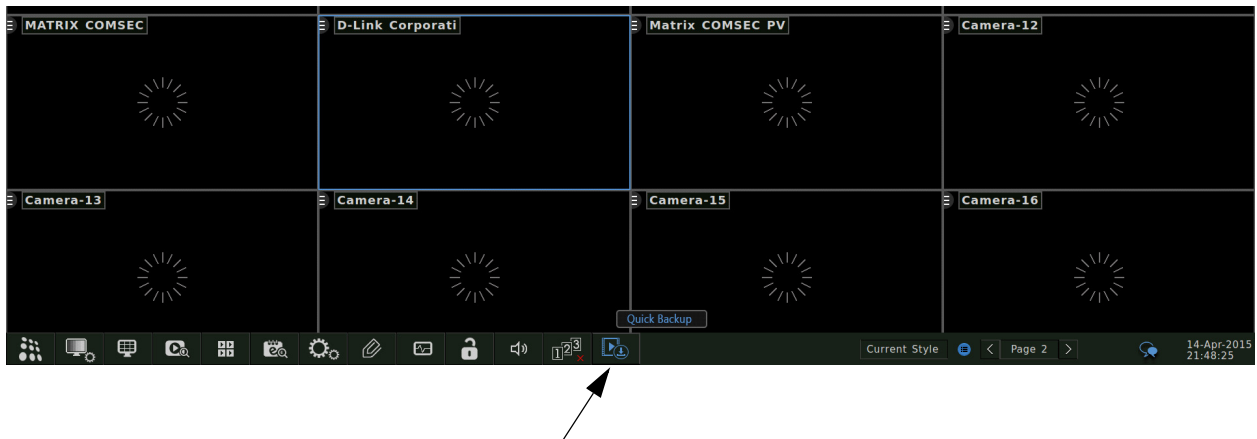

The following pop-up window appears as shown below.

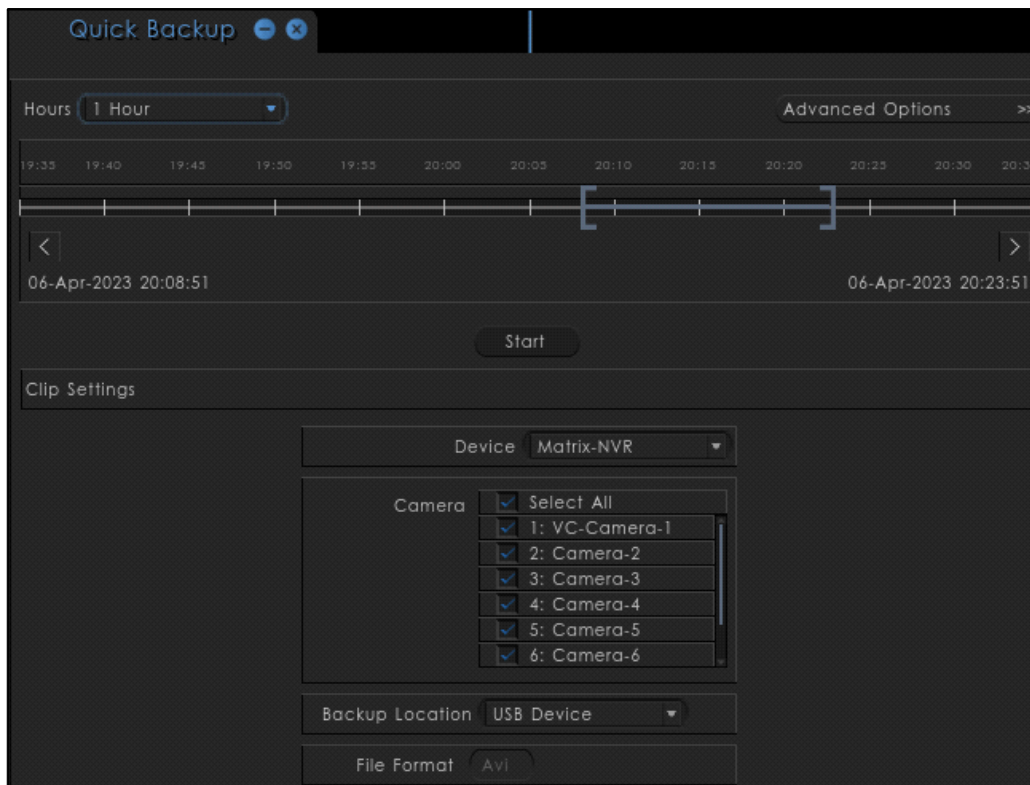

For all the settings, refer Device Client part of the manual for detailed explanation. See [“Quick Backup” on page 189](#).

Quick Setup

This option enables you to set up the basic parameters of NVRX/ NVRX P2 like Time and Language, Network, DHCP Server, Storage, Camera Configuration and Search Camera quickly.

Click **Quick Setup**  from the bottom pane. The **Quick Setup** pop-up appears.

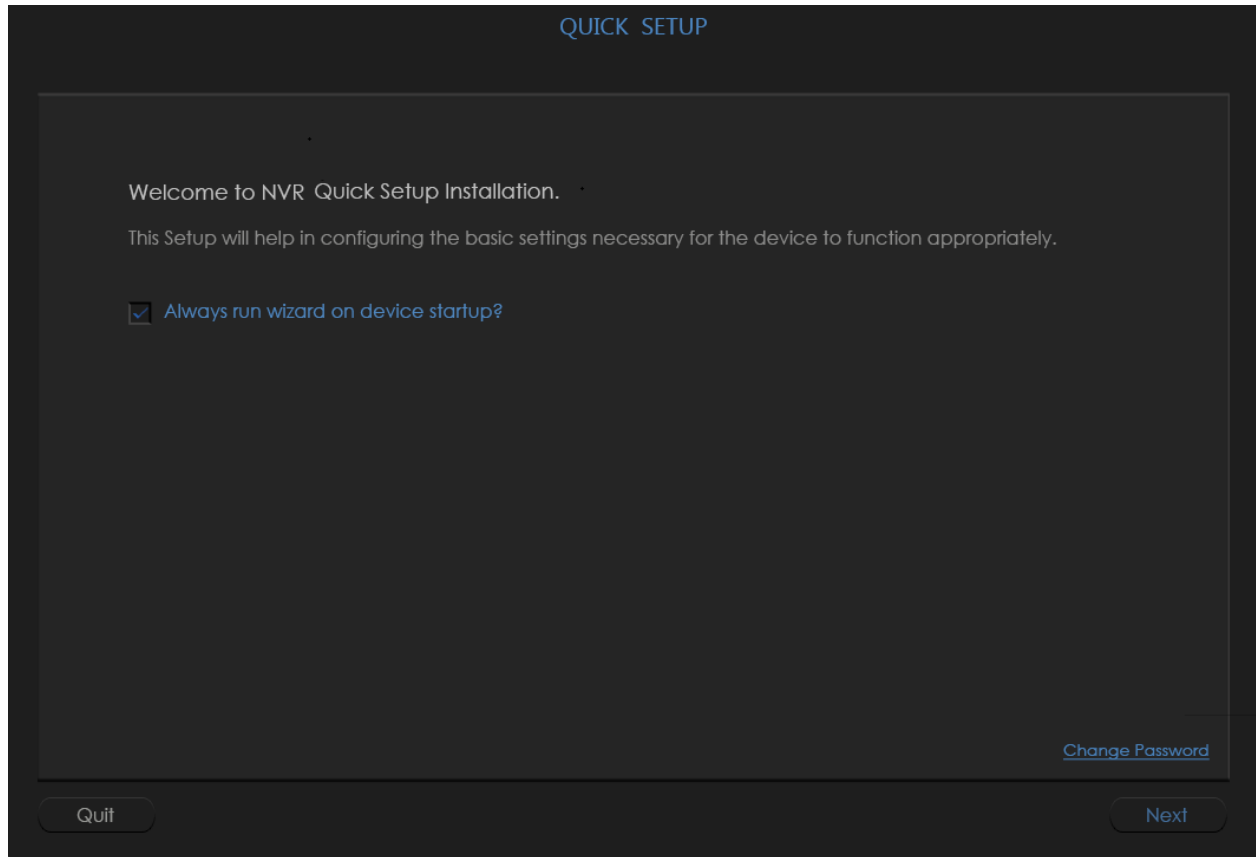

For the configuration of Quick Setup Wizard, refer to “[Quick Setup](#)”.

Click **Quit** to cancel the Quick Setup process.



The Quick Setup Wizard option is available only for the NVRX/NVRX P2 variants of SATATYA Devices.

Live Events

This icon is displayed on the toolbar whenever any live event occurs on the SATATYA device as shown below.

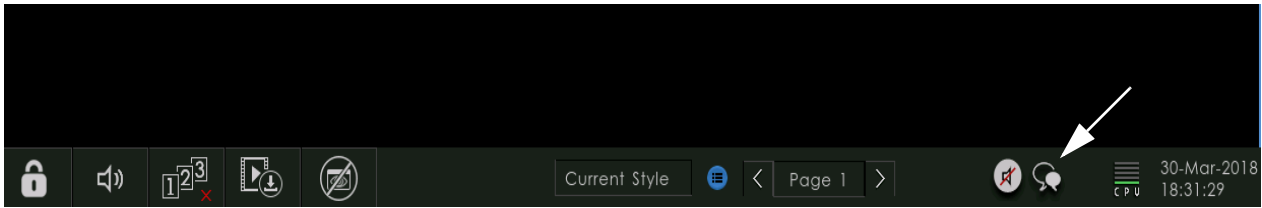

Also a message 'Event Notification' is displayed in the local UI. On clicking on **Live Events** icon on the toolbar, the notification page appears as shown. Here Live events of Device is shown.

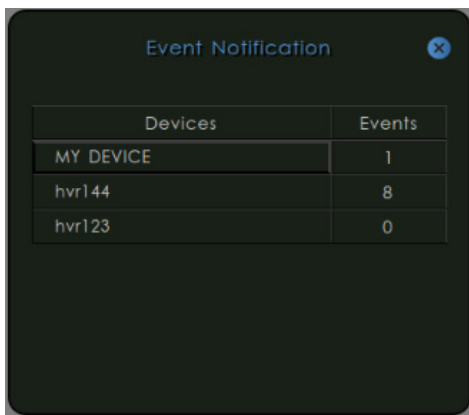

Click on the desired device to view the event list. The Event Notification with the Event details appears as shown below:

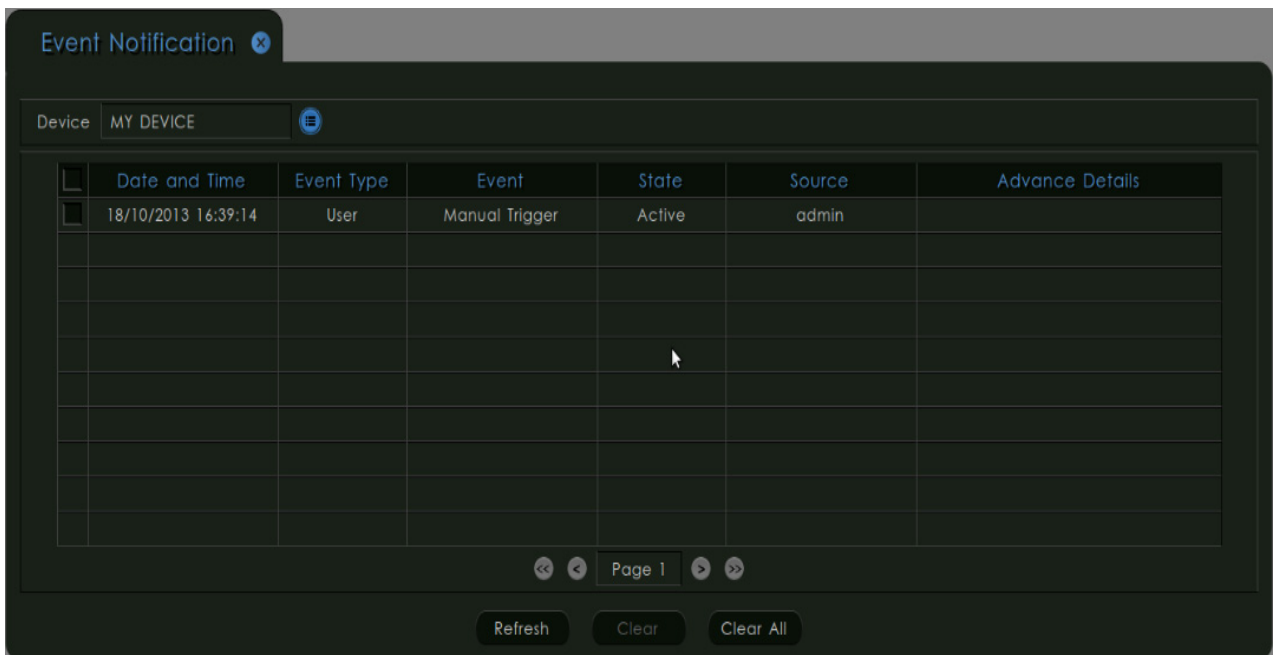

Select the desired device from the **Devices** pick list. The events related to the selected device will be displayed in the grid.

Refresh: Click on this button to relist all the live events of the selected device.

Clear: Click on this button after selecting the events to be cleared. Only the selected events will be cleared.

Clear All: Click on this button to clear all the events displayed on the grid.

The arrow buttons displayed at the bottom is used to navigate between the pages. The **Live Events** icon on the toolbar will disappear only after clearing all the events on the page and then closing the window using cross button at the top.

When inserting a USB drive for taking scheduled backup or manual backup, an icon is displayed on the toolbar as shown:



The tool tip 'Unplug USB' is displayed when the mouse cursor is moved over it. The inserted USB can be ejected by single left clicking on the icon once and then selecting the option **Eject Manual Backup USB**.

Similarly, for the device buzzer being active, an icon will be displayed on the toolbar as shown:



A single left click on the icon allows the user to **Stop** the buzzer.

Recording

In **SATATYA HVR** Devices, recordings can be done using maximum **24** cameras with the **Analog and IP** Camera Combination. The combination of Analog and IP Camera depends on the selection from General Settings window. Whereas, in **SATATYA NVR/NVRX** Devices, recordings can be done using maximum **64 IP** cameras, in **SATATYA NVRX P2** recordings can be done using maximum **96 IP** cameras and in **SATATYA NVRXS P2** recordings can be done using maximum **16 IP** cameras

To initialize the device, First connect the device with Power supply and Monitor. Then you will need to insert the hard disk in device and format the disk to erase anything stored on it. (See [“Powering the SATATYA device” on page 53.](#))

From the Live view of window, right click on the channel whose recording is to be started. Select **Start Recording**. The Manual Recording will be started.

From the **Tool Bar**, click **Settings**. Click **Camera Settings** and then **Recording**. Click and configure the parameters for **Manual**, **Alarm**, **Scheduled**, **COSEC Recording** and **Adaptive Recording**. For details for NVRX/ NVRX P2 Series, refer to [“Recording/Adaptive Recording Settings”](#) and for other series refer to [“Recording Settings”](#) and [“Adaptive Recording”](#)

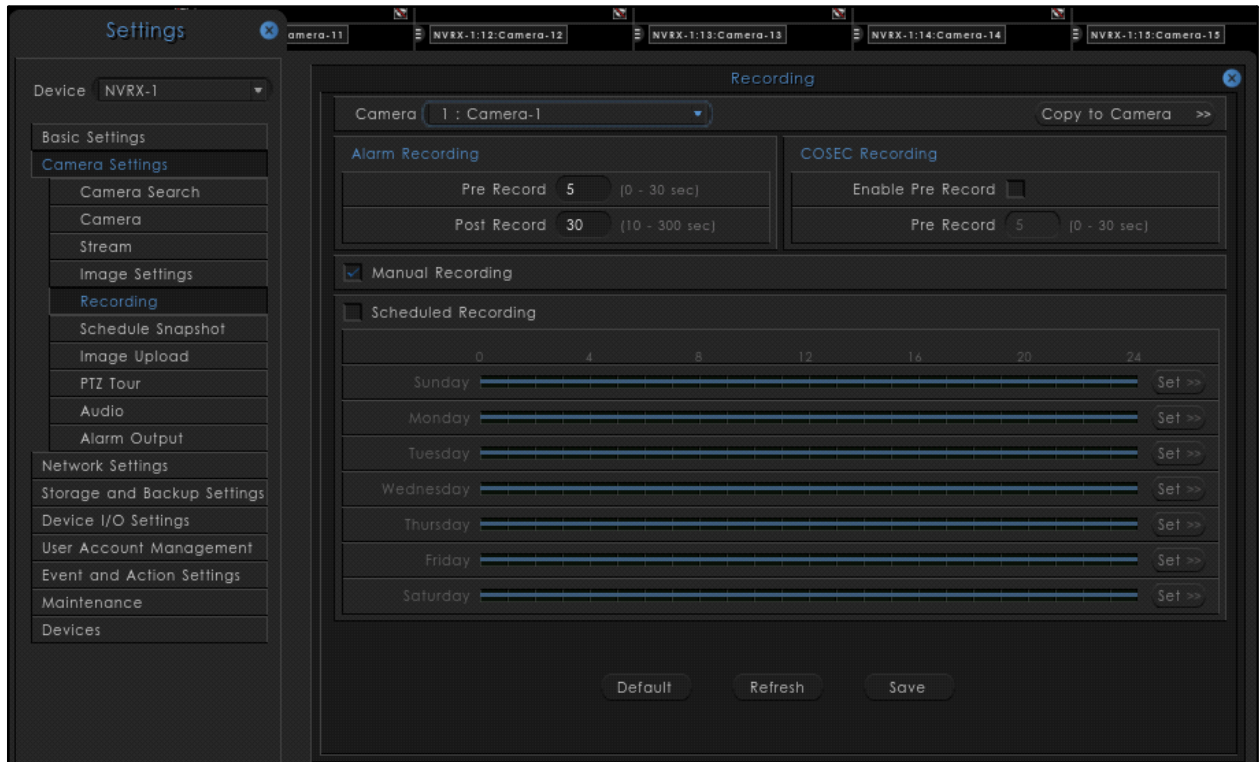

You can see the health status of recording in **System Status** from the **Tool Bar** (See “[Device Status](#)” on page 144.)

The Recording will be stored in Hard Disk. If the disk gets full, then it will get Over write if **Over write** option is enabled or else the recording will be stopped.

The Recording can also be backed up at Network Drive whose path is defined in **Storage and Backup Settings**. (See “[Storage and Backup Settings](#)” on page 315.)

Start Time: Click each option — HH, MM— and then select the desired value from the drop-down list to specify the Start Time of the recording.

End date: Select the **End Date** using the calendar button to specify the End Date of the recording.

End Time: Click each option — HH, MM— and then select the desired value from the drop-down list to specify the End Time of the recording.



The Start Time and End Time can be selected by clicking the up and down arrow buttons for all variants other than NVR/NVRX P2 series.

Type: Select the Type of Recording to be viewed in playback from the drop-down list. The options available are:

- All
- Manual
- Alarm
- Schedule
- COSEC

Camera: Select the desired Camera whose recording is to be played back from the drop-down list. The camera list contains only those cameras whose access rights are given to the user.

Search: Click on the Search button. The system will list the video events associated with the selected search filters in the **Record List** grid.

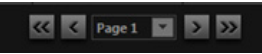
The  arrow buttons enables the user to browse through the various pages of the record list.

To view the playback of a particular record, select the recording and Click on **Play** button. The playback of the selected record starts in the selected window on the screen.

Right Click on the Playback window and Click on **Toolbar** button, the **Playback Control Panel** appears on the bottom of the window.

The **Playback Control Panel**, shown in the following figure contains the various controls on the Playback interface.



For the description on Playback control buttons, [See “Playback Toolbar” on page 169.](#)

Backup: The user can take backup of the selected files on USB for manual backup in AVI format by selecting the files and then clicking on **Backup** button. When selecting only single file, it is possible to crop the recorded video by defining start and end time of the record and then taking backup of the cropped file on the USB.

Synchronous Playback- Local

In order to view the Synchronous Recording i.e Recording on different channels starting from the same time, click on **Playback Search** from the **Tool bar** and select **Synchronous Playback**. The Synchronous Playback page appears as shown below:

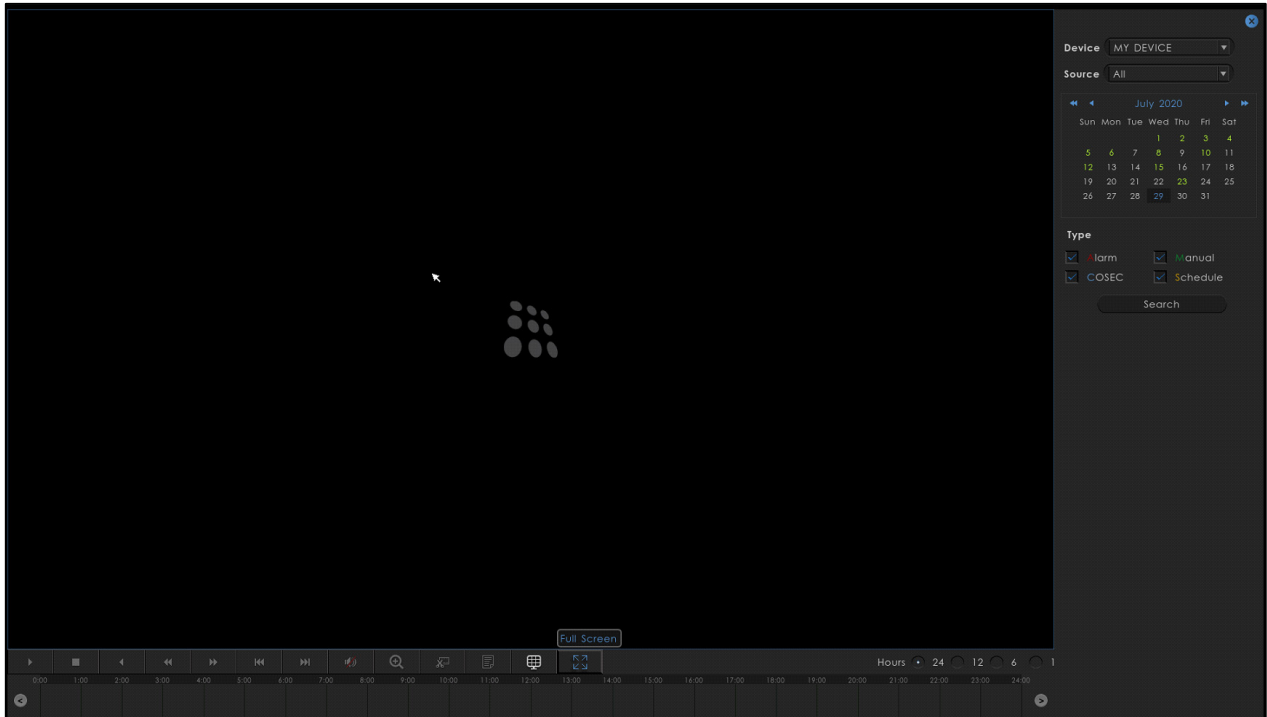

Source: Select the playback source from the options of Local Drive, Network Drive1, Network Drive2 and All, if you want to search the results from all of the mentioned sources.

Right Pane: The Right pane consist of Device Selection, Source Selection, Calender, Type Selection and Camera Selection.

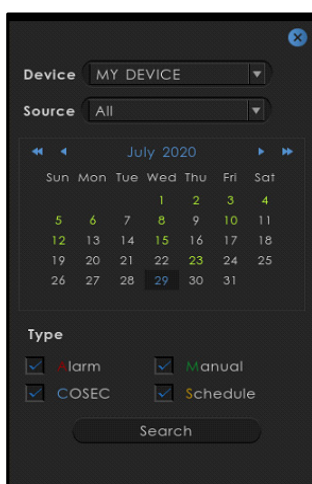

Calender: The dates for which the recording is available is shown by **green** color in Calender. The user can see the recording by clicking on the particular date which is green in color from the calender.

Types: Select required check boxes for the Event Type from the options:

- **A**larm
- **C**OSEC
- **M**anual
- **S**chedule

For each type of recording, a particular color is assigned on the basis of which it can be differentiated.

Click on the **Search** button to search the cameras for selected type of event.

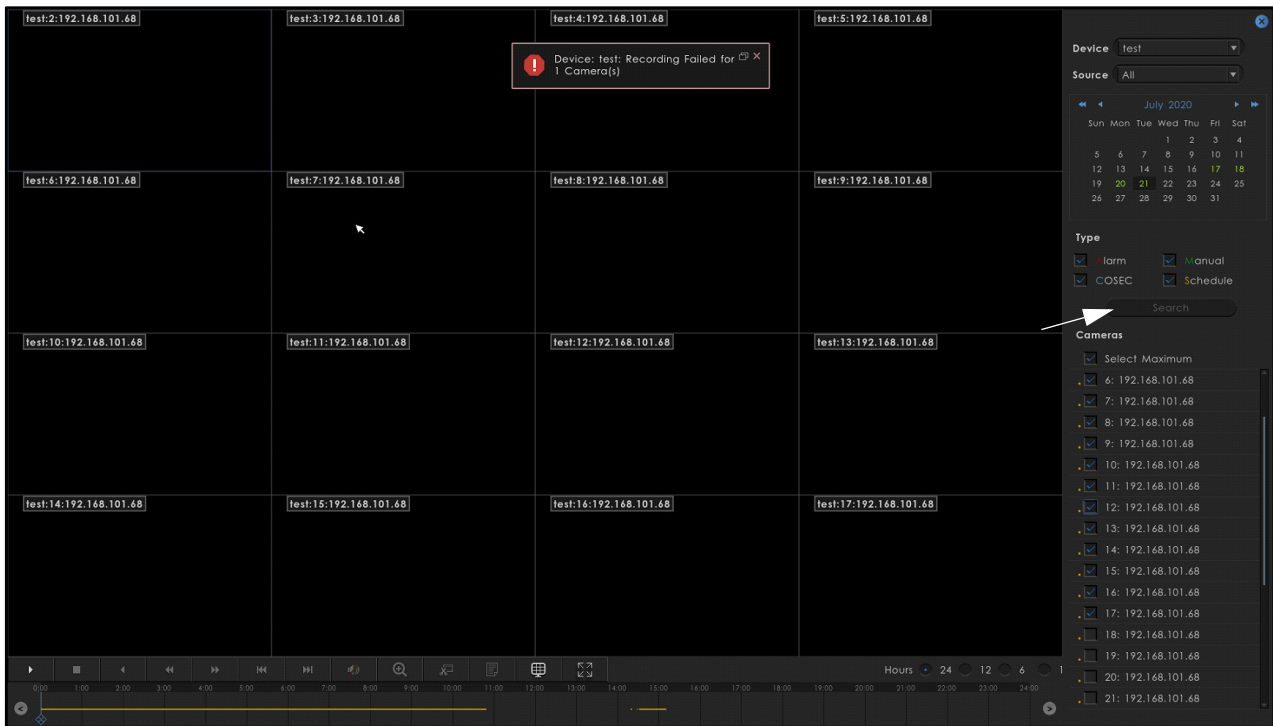

Cameras: Select the check boxes for the desired cameras whose recordings are to be searched and viewed. User can select maximum 16 cameras for the synchronous playback at a time.

Select the **Select Maximum** check box to select first 16 cameras available in the cameras column for playback.

The colored dot (.) besides the camera check box indicates the type of recording available in respective camera. If there are multiple recordings available in a single camera then, it will show accordingly as shown below.

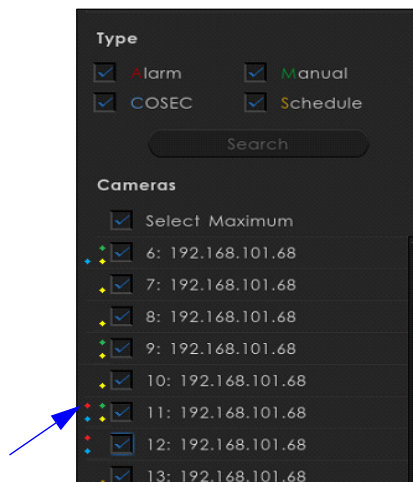

As per the number of cameras selected for playback, the display mode will be changed. i.e 1x1, 2x2, 3x3 or 4x4

You can change the display mode from the  **Display Mode** option.

The horizontal line showing the recording (length) of selected camera assigned in a particular window. This will be displayed in the time line as shown below:

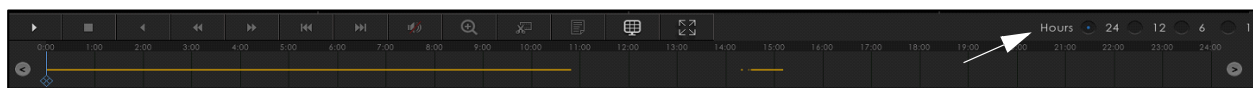

Hours: The user can view the finer details of recording by zooming into 1 hour or can be zoomed out to view the overall recordings of the day i.e 24 hours. The Time line will change according to the hours selection.

Select the time format from the options:

- 24 hours
- 12 hours
- 6 hours
- 1 hour

These different types of recording will be shown with different colors in Time-line where, Alarm has the highest priority and Schedule has the least priority.

For E.g: If there are all types of recordings are available in one minute, then only Alarm Recording will be shown as it has highest priority.

In case, Manual, Cosec and Schedule Recordings are available, then Cosec recording, being at the highest priority, will be displayed.



At a time only one recording type will be displayed as per the priority for selected camera.

For the description on Playback control buttons, See [“Playback Toolbar” on page 169](#).

To Start Playback: After specifying the date, Cameras, Hours and Event type, take the slider in Timeline to the position from where the playback is to be started.

Click on Play button  from the Tool bar. The Synchronous playback of the selected cameras will be started as shown below:

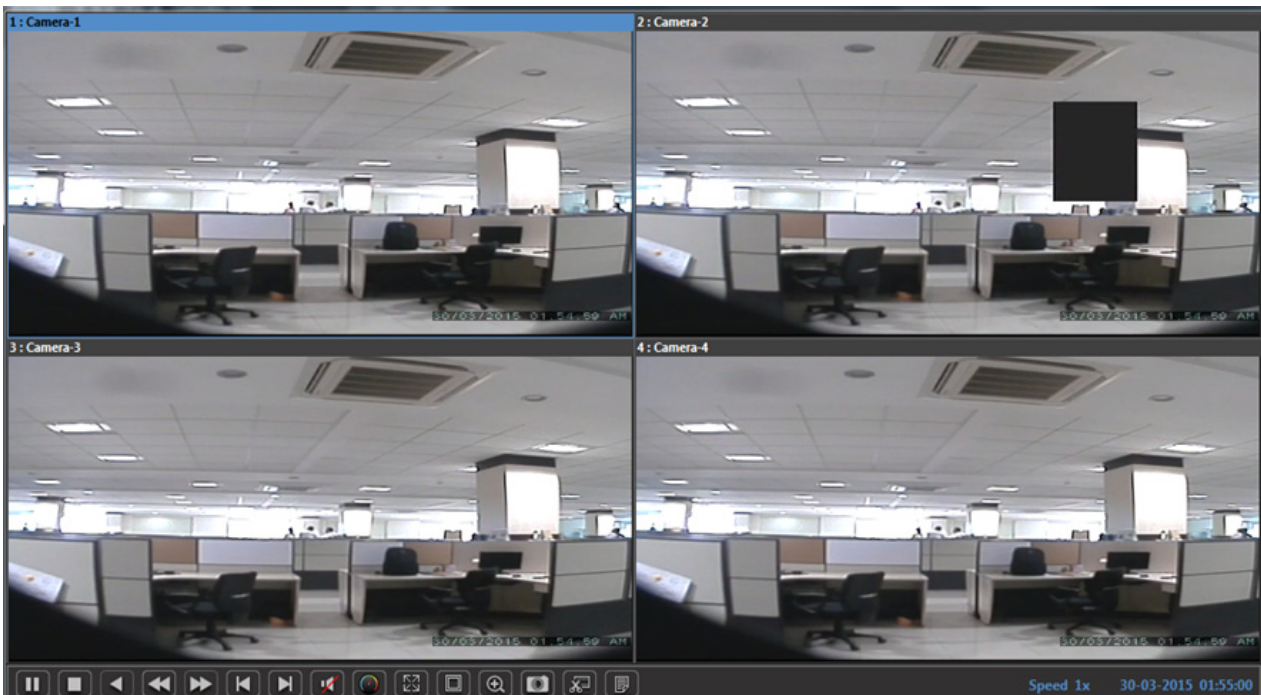

In Play mode, Search operations are not allowed. Calender and Cameras will be disabled.

For the Synchronous and Asynchronous playback in Local Client, Whenever user plays the video for added cameras in a monitoring window and if the maximum decoding limit to run the video stream has been reached (already) then, the user will be notified by the  **Decoding Error**. This will display on the window of respective cameras for which the stream can not be played.



User can reduce the number of playback camera's to reduce the Decoding Error.

Playback in Device Client

The Device Client has the provision for Local Playback from **Local Recordings** and Remote Playback from **Device Recordings**.

The Remote Playback option plays recorded files saved at the SATATYA device itself while the local playback option enables the user to select files stored on the device client computer. However, the user needs to ensure that the viewing window selected for viewing the playback does not have any live video being streamed from a connected camera.

To View the Recording from **Device client**, click on **Playback** from the **Left Pane**.

There are two types of Playback as mentioned below:

- **Device Recordings**
 - Asynchronous Playback

- Synchronous Playback

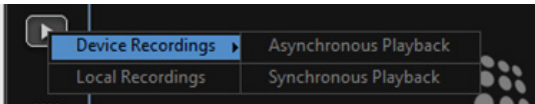

- Local Recordings

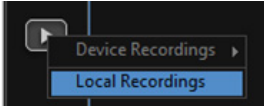

Asynchronous Playback- Device client

In order to access this functionality, click on **Playback** from the left pane of the device client page and select **Device Recordings** and click on **Asynchronous Playback**. The page appears as shown below:

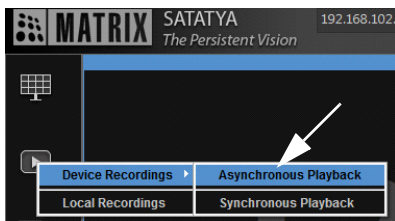

The 'Playback' window displays the following search filters:

- Device Name: Matrix-HVR
- Start Date Time: 14/ 5/2017 17:07
- End Date Time: 15/ 5/2017 18:07
- Source: All
- Type: All
- Camera: All

	Start Time	End Time	Camera	Type	Source	Play	Download Status
<input type="checkbox"/>	14-05-2017 20:09:58	14-05-2017 20:09:58	1	Schedule	Network Drive1	▶	
<input type="checkbox"/>	14-05-2017 20:09:58	14-05-2017 20:09:58	2	Schedule	Network Drive1	▶	
<input type="checkbox"/>	14-05-2017 20:09:58	14-05-2017 20:09:58	3	Schedule	Network Drive1	▶	
<input type="checkbox"/>	14-05-2017 20:10:38	14-05-2017 20:10:38	2	Schedule	Network Drive1	▶	
<input type="checkbox"/>	14-05-2017 20:10:38	14-05-2017 20:10:38	3	Schedule	Network Drive1	▶	
<input type="checkbox"/>	14-05-2017 20:10:39	14-05-2017 20:10:39	20	Schedule	Network Drive1	▶	
<input type="checkbox"/>	14-05-2017 20:10:40	14-05-2017 20:10:40	21	Schedule	Network Drive1	▶	
<input type="checkbox"/>	14-05-2017 20:10:59	14-05-2017 20:10:59	1	Schedule	Network Drive1	▶	
<input type="checkbox"/>	14-05-2017 20:11:59	14-05-2017 20:11:59	20	Schedule	Network Drive1	▶	
<input type="checkbox"/>	14-05-2017 20:12:00	14-05-2017 20:12:00	21	Schedule	Network Drive1	▶	
<input type="checkbox"/>	14-05-2017 20:12:39	14-05-2017 20:12:39	2	Schedule	Network Drive1	▶	
<input type="checkbox"/>	14-05-2017 20:12:39	14-05-2017 20:12:39	3	Schedule	Network Drive1	▶	
<input type="checkbox"/>	14-05-2017 20:12:40	14-05-2017 20:12:40	20	Schedule	Network Drive1	▶	
<input type="checkbox"/>	14-05-2017 20:12:40	14-05-2017 20:12:40	21	Schedule	Network Drive1	▶	
<input type="checkbox"/>	14-05-2017 20:13:19	14-05-2017 20:13:19	2	Schedule	Network Drive1	▶	

Asynchronous Playback

The **Asynchronous Playback** enables the user to browse and play the recorded files from the SATATYA device on the local computer.

The system offers search filters, allowing the user to locate a recorded video relating to a certain time period, recording type or camera.

Start Date Time: Specify the appropriate Start date and time period by scrolling the up down arrow.

End Date Time: Specify the appropriate End date and time period by scrolling the up down arrow.

Source: Select the source type from the **Source** drop-down list. The options available are:

- All
- Local Drive
- Network Drive1
- Network Drive2

If the user selects Source as **All**, then records will be searched in all the three drives i.e. Local Drive, Network Drive1 and Network Drive2. By default, the Source is set to "All".

Type: Select the recording type from the **Type** drop-down list. The options available are:

- All
- Manual
- Alarm
- Schedule
- Cossec

Camera: Select the desired camera from the drop-down list. The list contains only those cameras whose rights are given to the user.

Click on the **Search** button. The system will list the video recording events associated with the selected search filters.

In the absence of any records the system will display the **No Records Found** message. The user may then modify the search criteria.

In order to playback a recorded video, select a window on the Device Client screen and click on Play  button. The video will be played back in the selected window on the Device Client page as shown below:

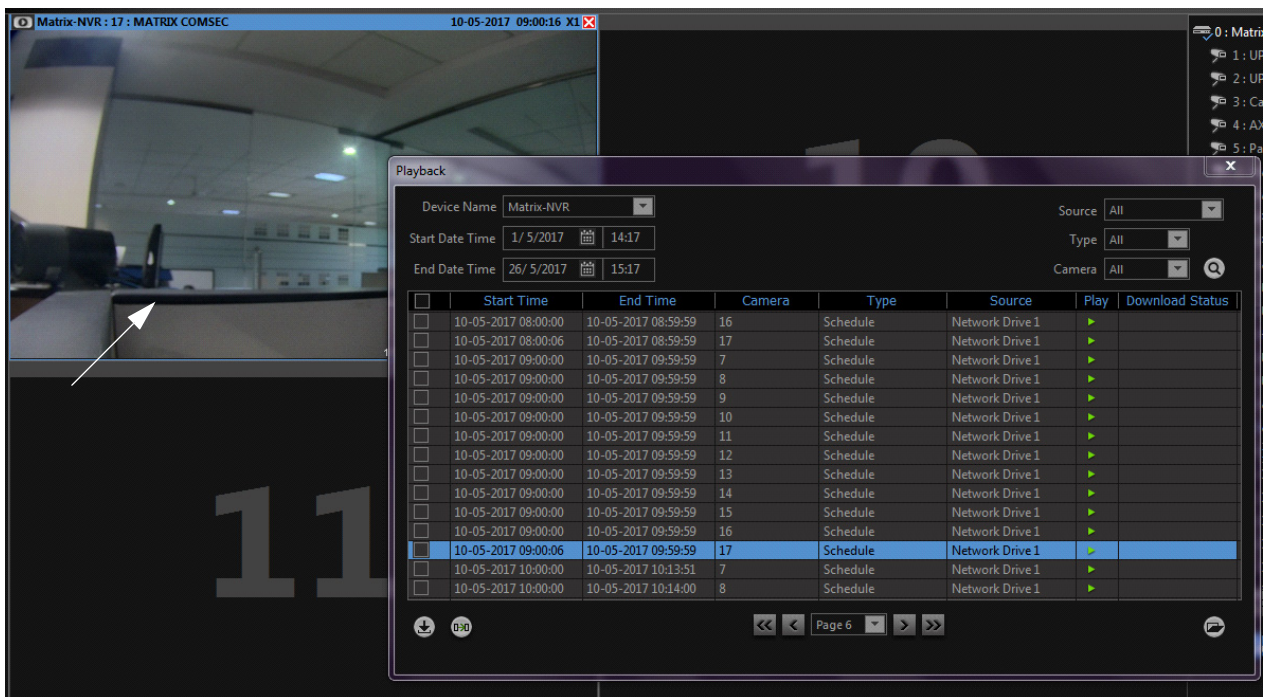

The screenshot displays the Matrix-NVR interface. A video playback window is open, showing a camera feed of an office interior. A white arrow points to a specific window in the background. In the foreground, a 'Playback' dialog box is visible, containing search filters and a table of recording events.

Playback Dialog Box Fields:

- Device Name: Matrix-NVR
- Start Date Time: 1/5/2017 14:17
- End Date Time: 26/5/2017 15:17
- Source: All
- Type: All
- Camera: All

<input type="checkbox"/>	Start Time	End Time	Camera	Type	Source	Play	Download Status
<input type="checkbox"/>	10-05-2017 08:00:00	10-05-2017 08:59:59	16	Schedule	Network Drive1		
<input type="checkbox"/>	10-05-2017 08:00:06	10-05-2017 08:59:59	17	Schedule	Network Drive1		
<input type="checkbox"/>	10-05-2017 09:00:00	10-05-2017 09:59:59	7	Schedule	Network Drive1		
<input type="checkbox"/>	10-05-2017 09:00:00	10-05-2017 09:59:59	8	Schedule	Network Drive1		
<input type="checkbox"/>	10-05-2017 09:00:00	10-05-2017 09:59:59	9	Schedule	Network Drive1		
<input type="checkbox"/>	10-05-2017 09:00:00	10-05-2017 09:59:59	10	Schedule	Network Drive1		
<input type="checkbox"/>	10-05-2017 09:00:00	10-05-2017 09:59:59	11	Schedule	Network Drive1		
<input type="checkbox"/>	10-05-2017 09:00:00	10-05-2017 09:59:59	12	Schedule	Network Drive1		
<input type="checkbox"/>	10-05-2017 09:00:00	10-05-2017 09:59:59	13	Schedule	Network Drive1		
<input type="checkbox"/>	10-05-2017 09:00:00	10-05-2017 09:59:59	14	Schedule	Network Drive1		
<input type="checkbox"/>	10-05-2017 09:00:00	10-05-2017 09:59:59	15	Schedule	Network Drive1		
<input type="checkbox"/>	10-05-2017 09:00:00	10-05-2017 09:59:59	16	Schedule	Network Drive1		
<input checked="" type="checkbox"/>	10-05-2017 09:00:06	10-05-2017 09:59:59	17	Schedule	Network Drive1		
<input type="checkbox"/>	10-05-2017 10:00:00	10-05-2017 10:13:51	7	Schedule	Network Drive1		
<input type="checkbox"/>	10-05-2017 10:00:00	10-05-2017 10:14:00	8	Schedule	Network Drive1		

Play back to back recordings feature for Asynchronous Playback

This feature allows the users to view the recordings of the same camera one after the other. To access this feature user can follow the steps below:

- Search the recordings by applying the required filters in the Asynchronous Playback.
- Click on the recording you want to play on the live view window.
- When the recording gets finished, three controls will be displayed to the user on the screen i.e., Previous, Replay and Next button as shown in the screen below.

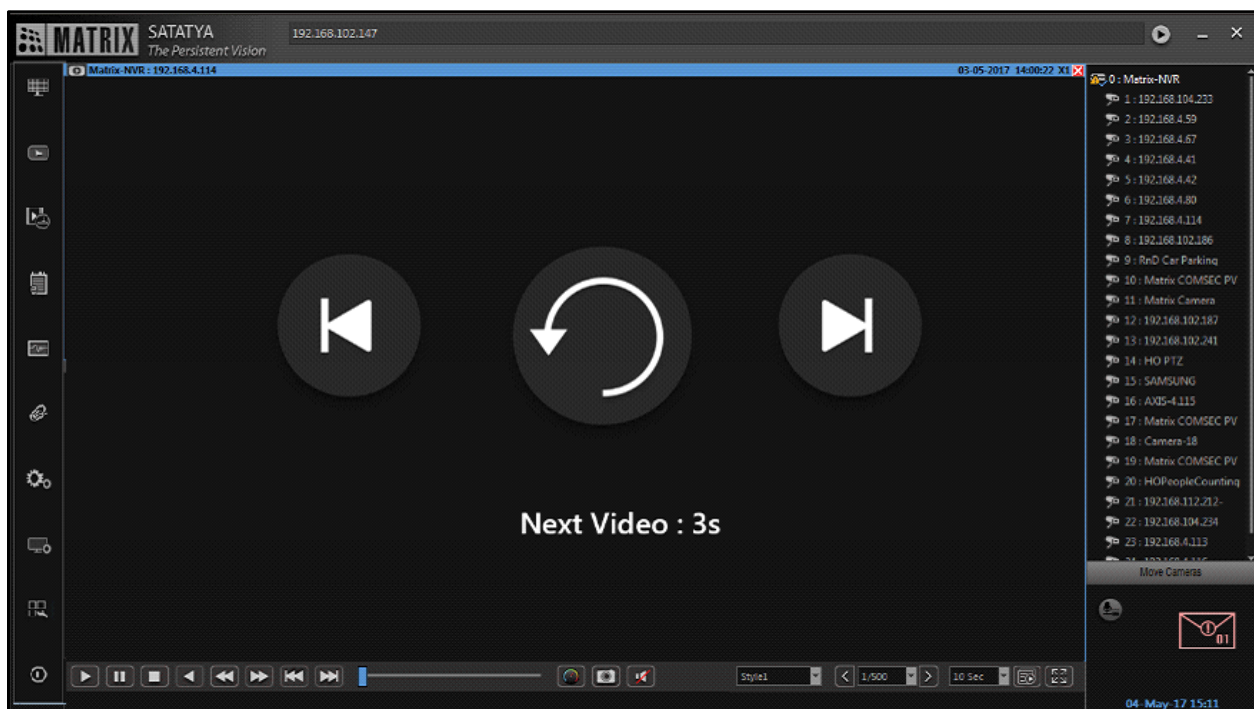

The controls will be seen to the user based on the scenarios explained below.

Scenarios:

1. If the recordings of the same camera is available, then the next button will be enabled for the user along with the timer count down display at the center of the playback window to play the next video as shown above. If the user does not click on any of the buttons within 5 seconds then next recording will be played automatically.
2. If the previous recording of the same camera is not available then the previous button will remain disabled.
3. If the next recording of the same camera is not available, then the next button will remain disabled.



1. Play back to back recordings feature for Asynchronous Playback will work only till the search results are not updated. Once the search results are updated, user will not be able to view recordings one after the other.

2. If the Asynchronous Playback pop up is closed and then reopened, all the configured filters including Start Date Time and End Date Time, Source, Type, Camera will be retained.

3. This feature is available in both Device Client and Local Client.

In the **Local Client**, the Timer count down to play the next video will be displayed around the play button as shown in the screen below.



View recordings from Local Playback file

In order to view a recorded file from the local hard disk, click on the **Select local playback file** icon as shown. The user can then browse to the appropriate file.

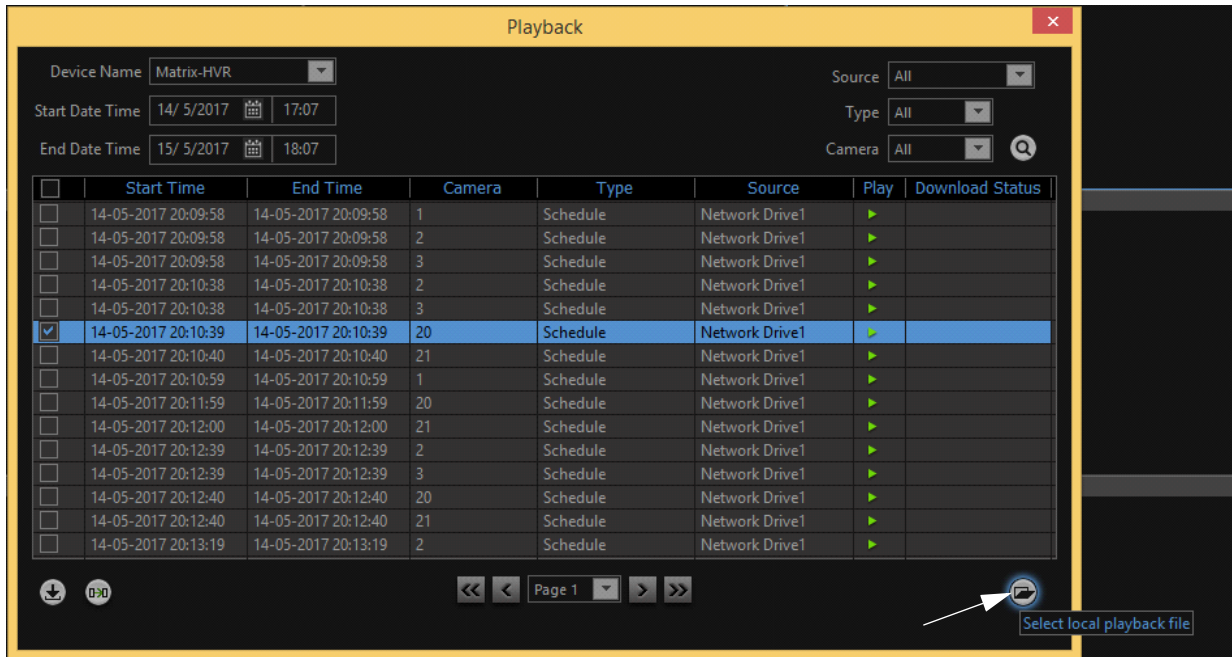

Click on the **Browse** button and select the file to be played. Double click on the stored file. The video will be played back in the selected window on the Device Client page as explained earlier.

The user can export a recorded file and play it back at a place where the SATATYA device is not accessible using the Device Client. This can be done using the **AVI conversion** option.

Downloading recorded files

The Device Client has the option to download recorded files from the device to the local hard disk of the computer. In order to access this functionality, select the recordings to be downloaded. Now click on the **Native download** and **AVI download** icon as shown.

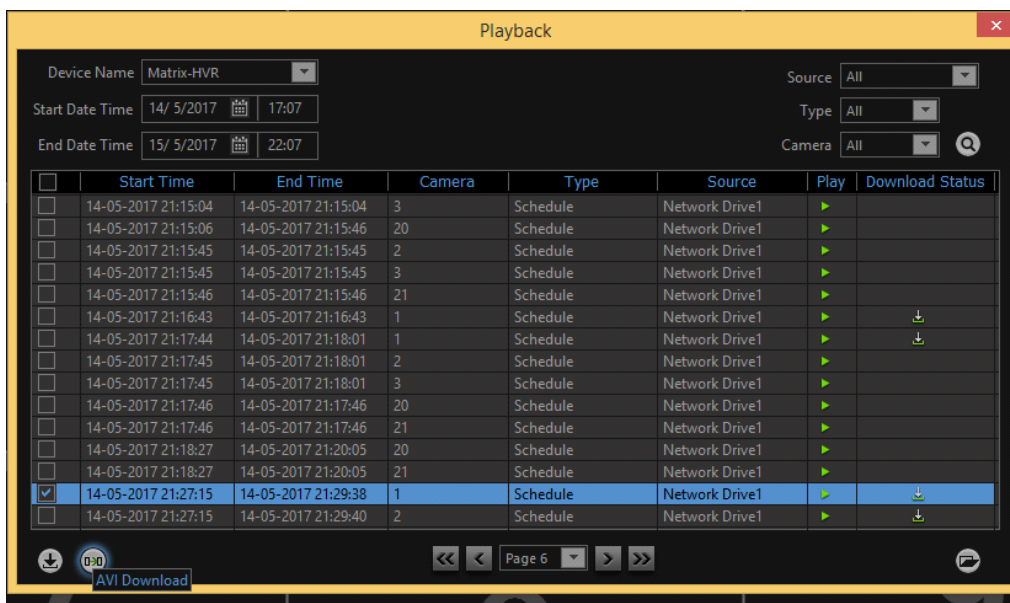

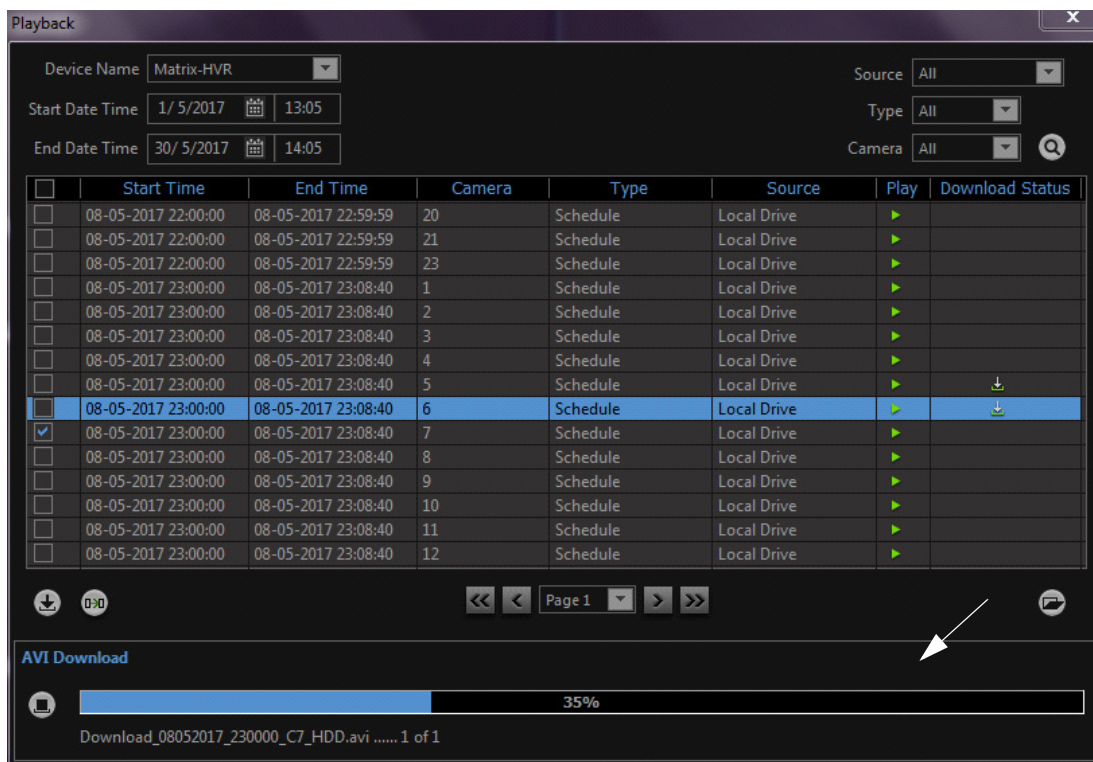

Click on the **AVI Download** button to begin the download process.

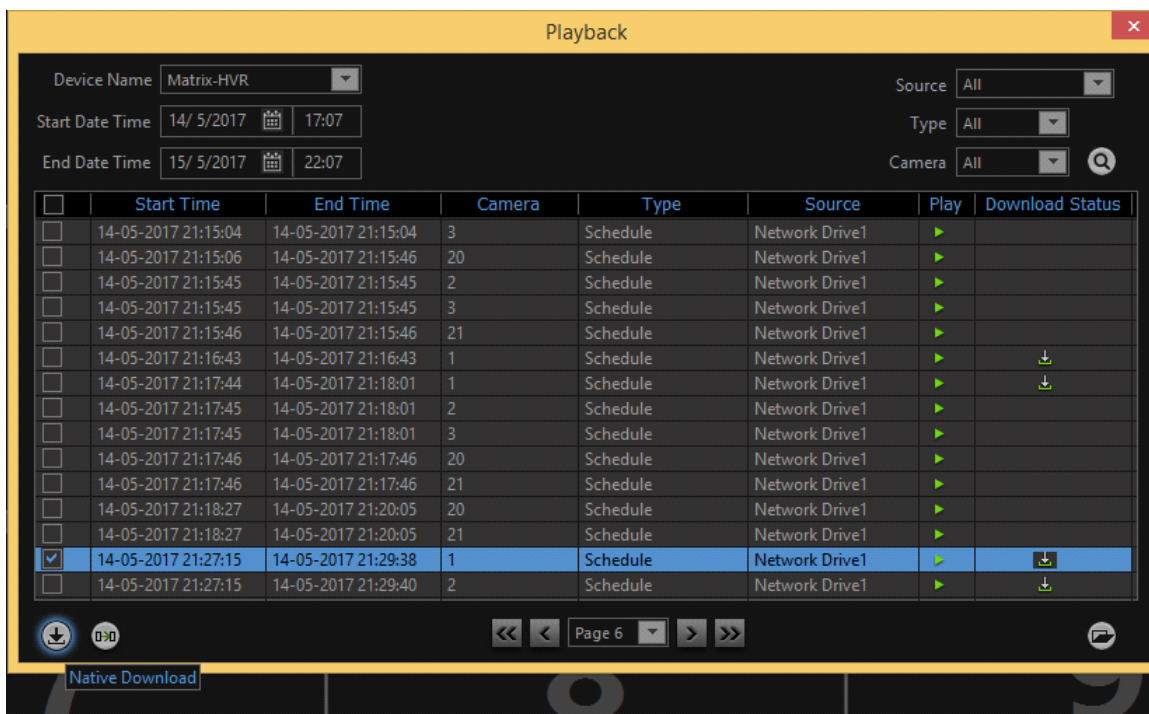

Click on the **Native Download** button to begin the download process. The system will display the download status as shown above.

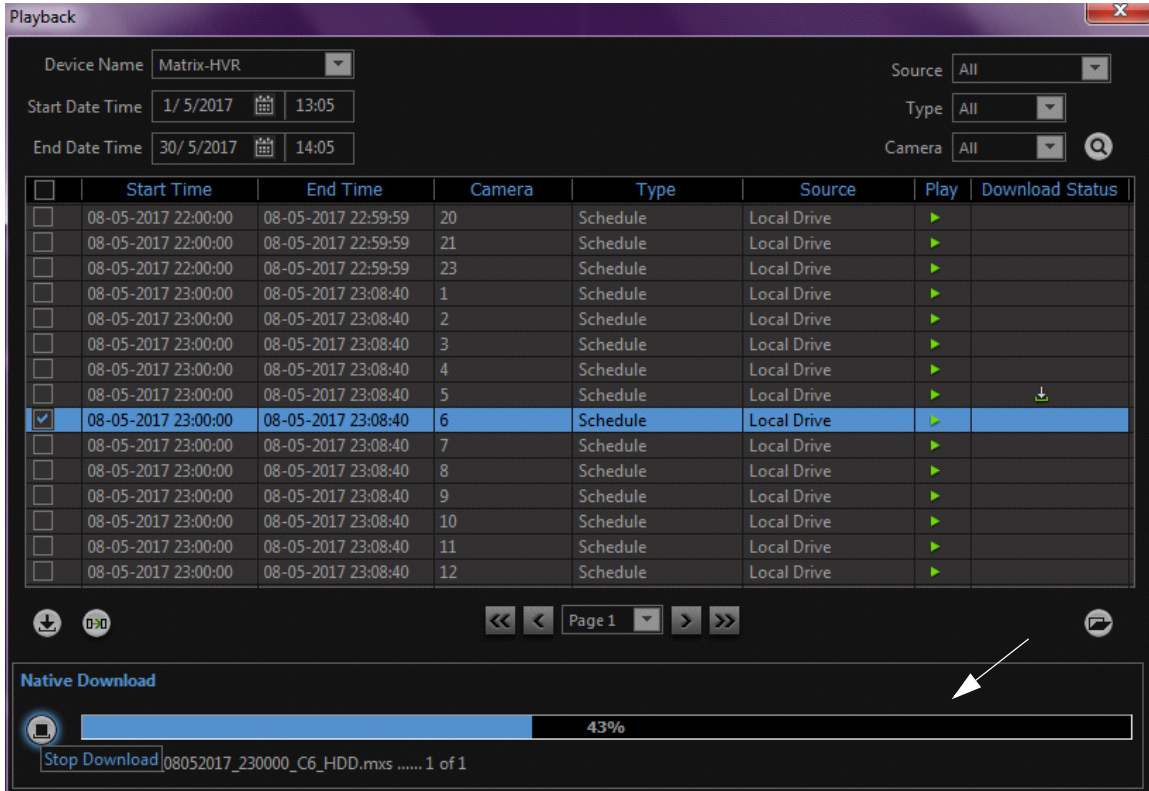



After downloading is completed, the status is marked by 

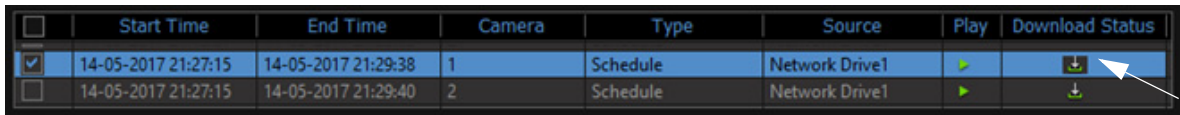

Playback Control Buttons



For the description on Playback control buttons in device client, [See “Playback Toolbar” on page 169.](#)

Close: Click on the cross button to close the playback session on a particular window.

Synchronous Playback- Device Client

In order to access this functionality in Device client, click on the **Playback** icon from the left pane of the device client page. Select **Synchronous Playback**. The Synchronous playback window appears as follows:

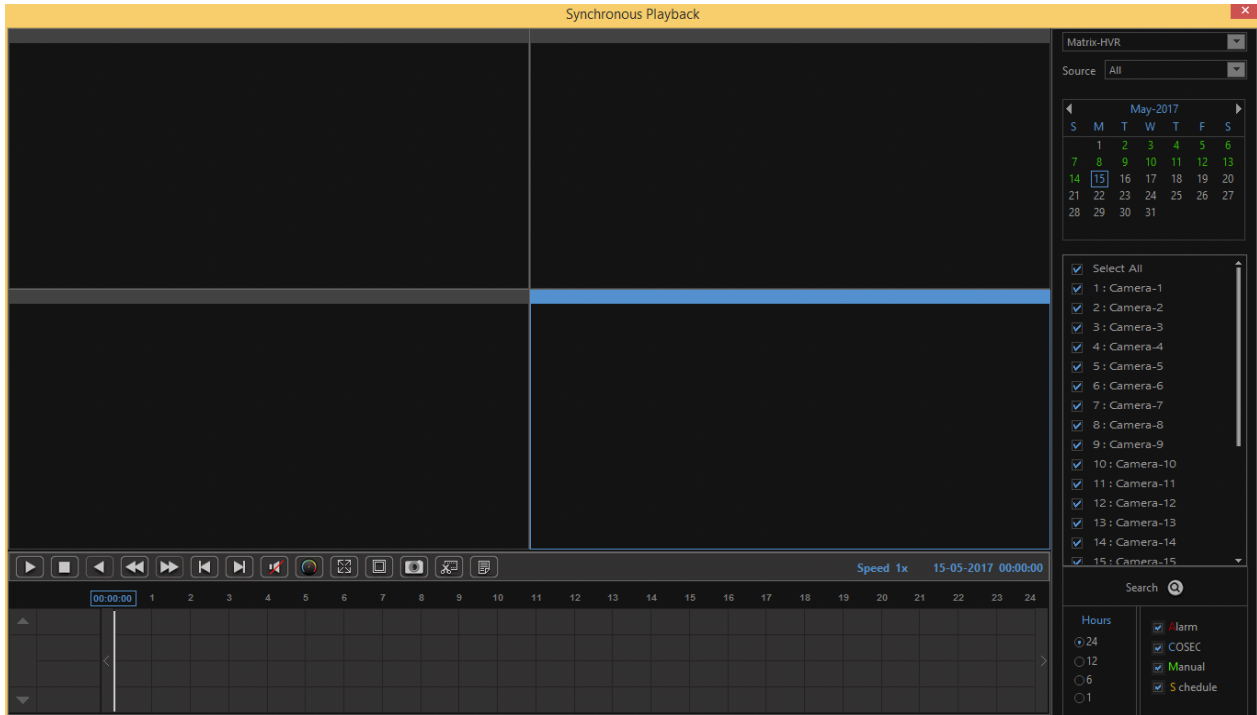

When the Synchronous playback is stopped, Live view of the cameras will be resumed and Asynchronous playback will be stopped.

Source: Select the playback source from the options of Local Drive, Network Drive1, Network Drive2 and All, if you want to search the results from all of the mentioned sources.

Right Pane: The Right pane consist of Device Selection, Source Selection, Calender, Camera Selection, Hours and Types Selection.

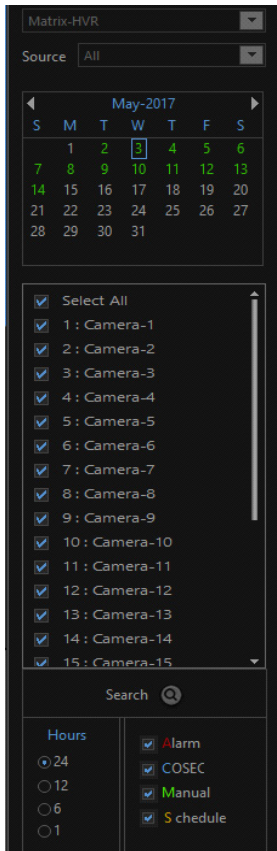

Calendar: The dates for which the recording is available is shown by **green** color in Calendar. The user can see the recording by clicking on the particular date which is green in color from the calendar.

The horizontal lines showing the recording will be displayed in the timeline as shown below:

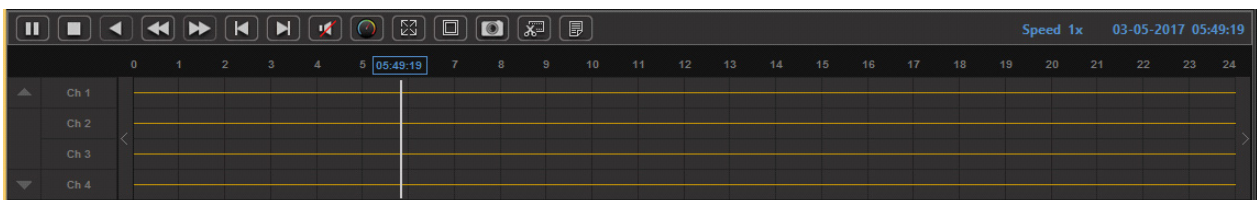

Cameras: The user can select the cameras whose recordings are to be searched and viewed. Check the box for the cameras whose recordings are to be viewed.

The Selected Cameras will appear in the first column of the **Timeline** as shown above. **Ch1- Ch4** Cameras are displayed above. Use the up-down arrows to view other Cameras.

Hours: The user can view the finer details of recording by zooming into 1 hour or can be zoomed out to view the overall recordings of the day i.e 24 hours. The Time line will change according to the hours selection.

Select the time format from the options of

- 24 hours
- 12 hours
- 6 hours
- 1 hour

Types: Select the Event Type from the options of

- **Alarm**
- **COSEC**
- **Manual**
- **Schedule**

These different types of recording are shown with different colors in Time-line where, Alarm has the highest priority and Schedule has the least priority.

For E.g: If there are all types of recordings are available in one minute, then Alarm Recording will be shown as it has highest priority.

In case, Manual, Cosec and Schedule Recordings are available, then Cosec recording, being at the highest priority, will be displayed.

If there is an overlap of recording for a particular camera on a particular date, then **Overlap** indication is shown for that camera.

To Start Playback: After specifying the date, Cameras, Hours and Event type, take the slider in Time-line to the position from where the playback is to be started.

Click on Play button  from the Tool bar. The Synchronous playback of the selected cameras will be started as shown below:

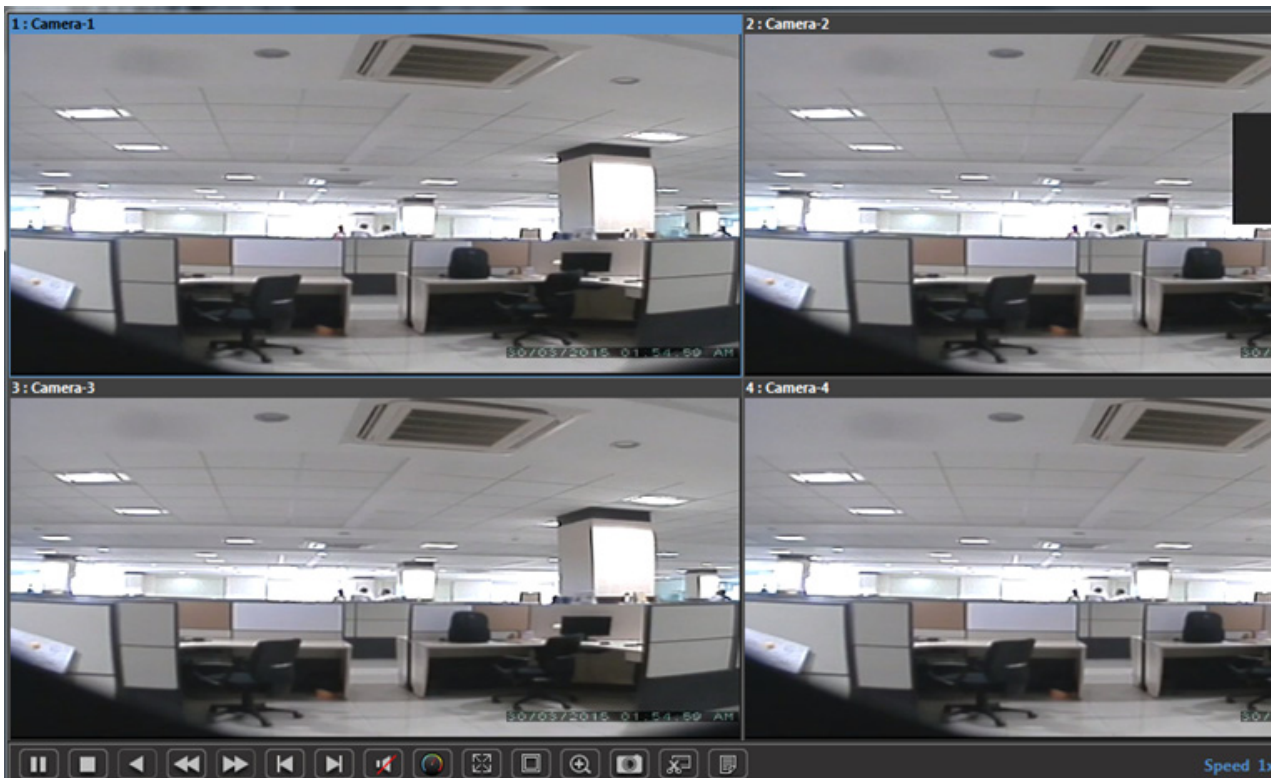

In Play mode, Search operations are not allowed. Calendar and Cameras will be disabled.

Playback Controls



For the description on Playback control buttons in device client, See [“Playback Toolbar” on page 169](#).

Playback Toolbar

Buttons	Description
Play/Pause	Click to play or resume playback of recorded video.
Stop	Click to stop and close the playback.
Reverse Play	Rewinds the video clip at normal speed. However, user needs to first click on the Pause button before clicking on this button.
Slow	Click to reduce the speed of the video normal or reverse playback. Playback speed is shown at the upper right corner of the playback window. The speeds range from 1/16x to 16x.
Fast	Click to increase the speed of the video normal or reverse playback. Playback speed is shown at the upper right corner of the playback window. The speeds range from 1/16x to 16x.
Previous Frame	Click to play the previous frame of the record.
Next Frame	Click to play the next frame of the record.
Enable Audio	Brings up the volume control slider to enable the user to adjust the playback audio volume.
Color	Click to set Brightness, Contrast, Saturation, hue and Audio parameters.
Full view/ Normal view	Click to get the full view of screen and back to normal view
Layout	Click to change the layout from 1x1 to 2x2 and vice versa.
Zoom	Click to Zoom the view.
Snapshot	Click to take the Snap of the view. The snapshot image can also be printed.
Clip Making	For Clip making, See “Clip Making” on page 170 .
Clip List	For Clip List, See “Clip List” on page 170 .

Note: Some of the Tool bar icons differ for local and device client and for Asynchronous and Synchronous Playback.

Clip Making

This feature enables the cropping of records and making clips. The user can also mark for the clips while playback is done.

To make the clip, take the slider to the required position where the clip is to be started in the Time-line. The message will be displayed as **Clip making Started**.

Now take the slider to the end position of the clip in the Time-line. The message will be shown as **Clip making Stopped**.

Clip List

Click on the Clip list button. The list of all the clips will appear as shown below:

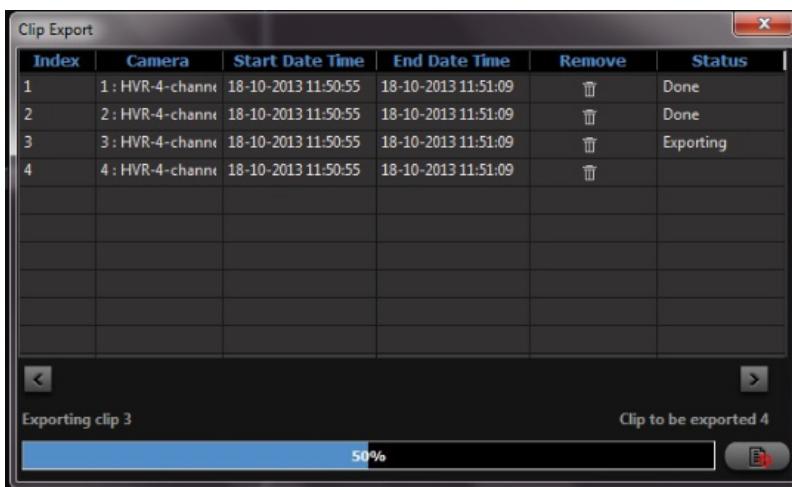

Index	Camera	Start Date Time	End Date Time	Remove	Status
1	1 : HVR-4-chann	18-10-2013 11:50:55	18-10-2013 11:51:09	🗑	Done
2	2 : HVR-4-chann	18-10-2013 11:50:55	18-10-2013 11:51:09	🗑	Done
3	3 : HVR-4-chann	18-10-2013 11:50:55	18-10-2013 11:51:09	🗑	Exporting
4	4 : HVR-4-chann	18-10-2013 11:50:55	18-10-2013 11:51:09	🗑	

Exporting clip 3 Clip to be exported 4

50%

Select the Clip to be exported. Click on **Export** button to export the clip. In Local Client, the Clip will be exported as per the Backup Location set in Storage and Backup Settings. See [“Manual Backup” on page 326](#). In device client, the clip will be exported to the path as defined in [“Local Settings”](#).

Local Recordings

The Device Client has the provision for Local Playback of the **Recordings** stored on the computer.

In order to access this functionality, click on the Playback and select **Local Recordings** from the left pane of the Device Client page. The page appears as shown below:

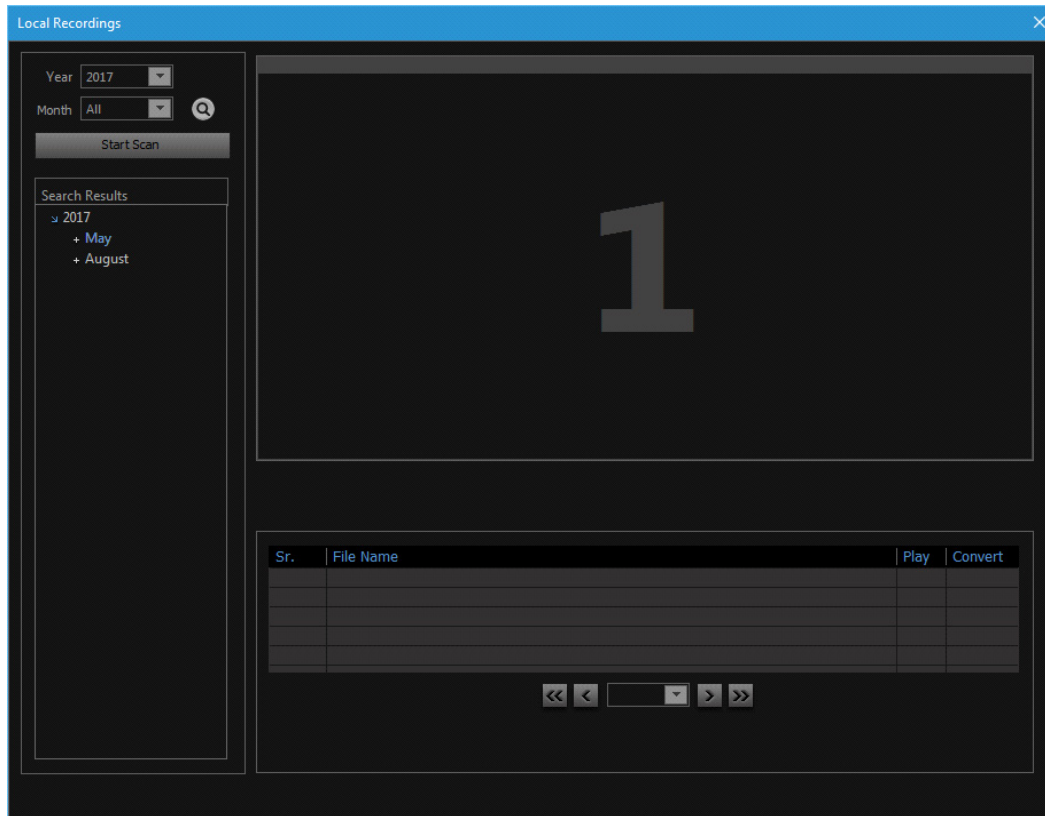

Click on **Scan** button to scan the computer for the stored native and avi files. All the drives will be scanned for the recording files.

Select the desired **Year** and **Month** from the drop-down lists. Then click on **Search** button. The selection will be shown as below:

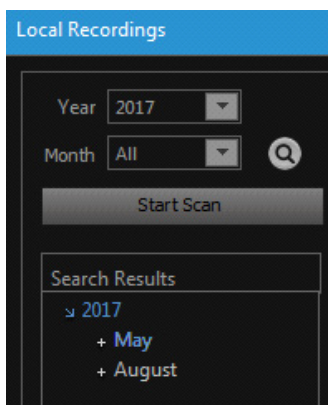

Click on the particular month and select the file. Click on **Play** button from the grid below to play back the recorded **native** file. The playback will be started as shown below:

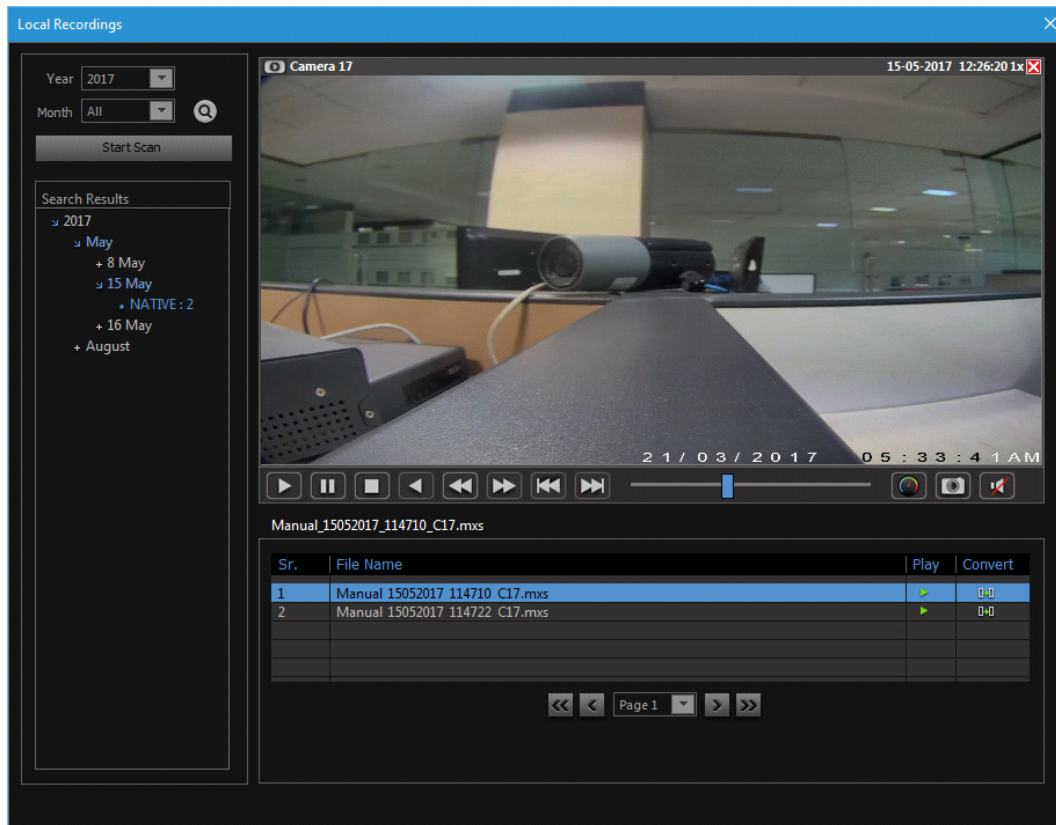

The playback speed can be varied from the toolbar See [“Playback Toolbar” on page 169](#). You can click on **Close** button to stop the playback.

Select the AVI file and Click on **Play** button to play back the recorded **avi** file.

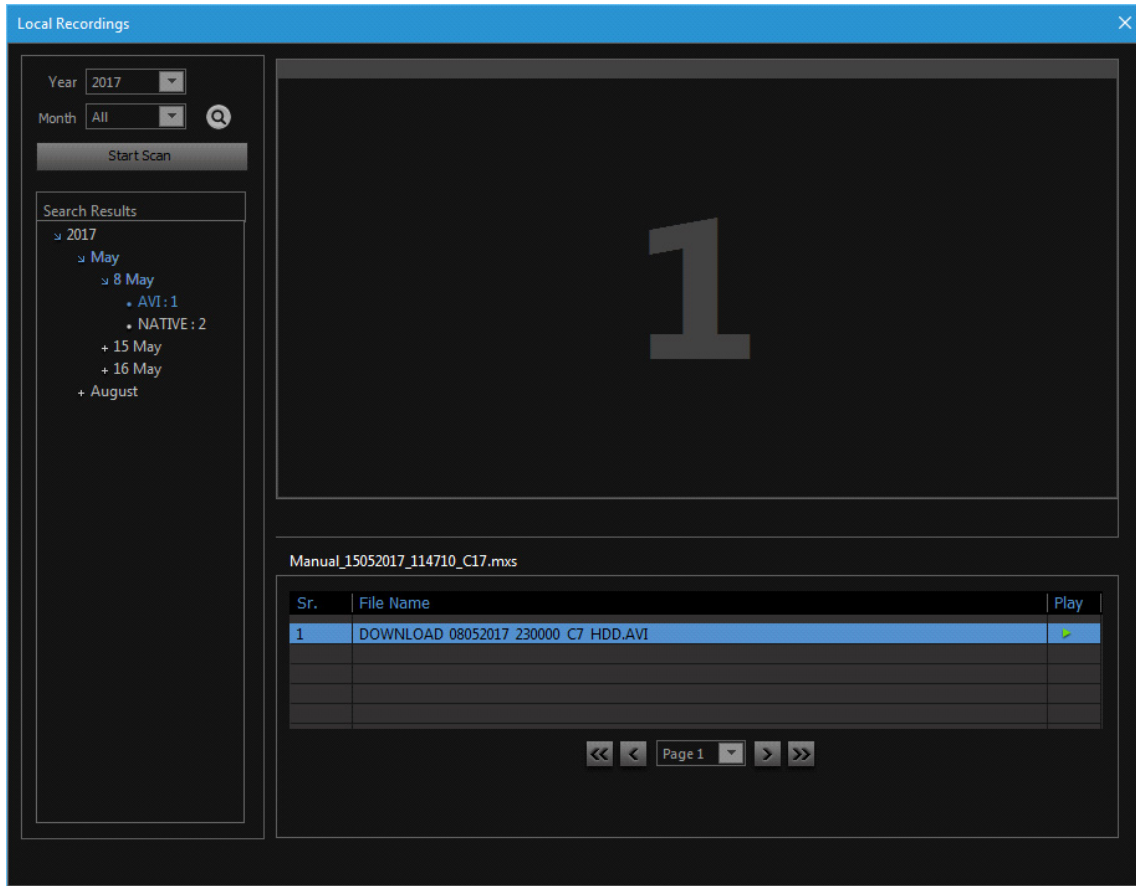

The window for selecting the media player will open. Select the media player to playback the avi file.

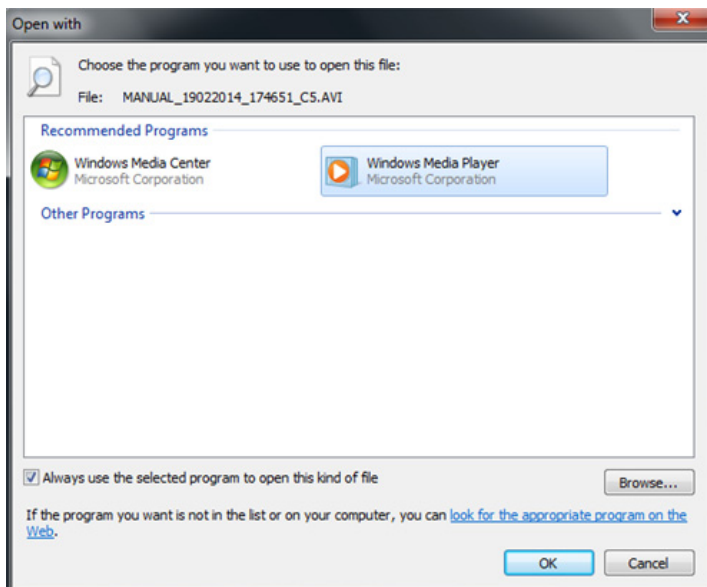

The Device Client is the on-board web server available on the SATATYA Devices. The Device Client is an inbuilt web based command and control application designed for use with enterprise, remote and network applications.

The Device Client allows users to remotely access, search, browse, display and transfer stored video and image files to a remotely connected workstation. Additionally, users may simultaneously view, search and archive up to 24 video channels, control access through administrative and user level password assignments, remotely configure SATATYA device and individual camera settings and receive notification of events such as alarm, motion/no motion detection and video loss.

For detailed installation and login process, refer to [“Installing and Accessing the Device Client”](#) and [“Login - Device Client”](#).

Once you login, the Device Client Live View screen appears, with the default display layout (2x2).

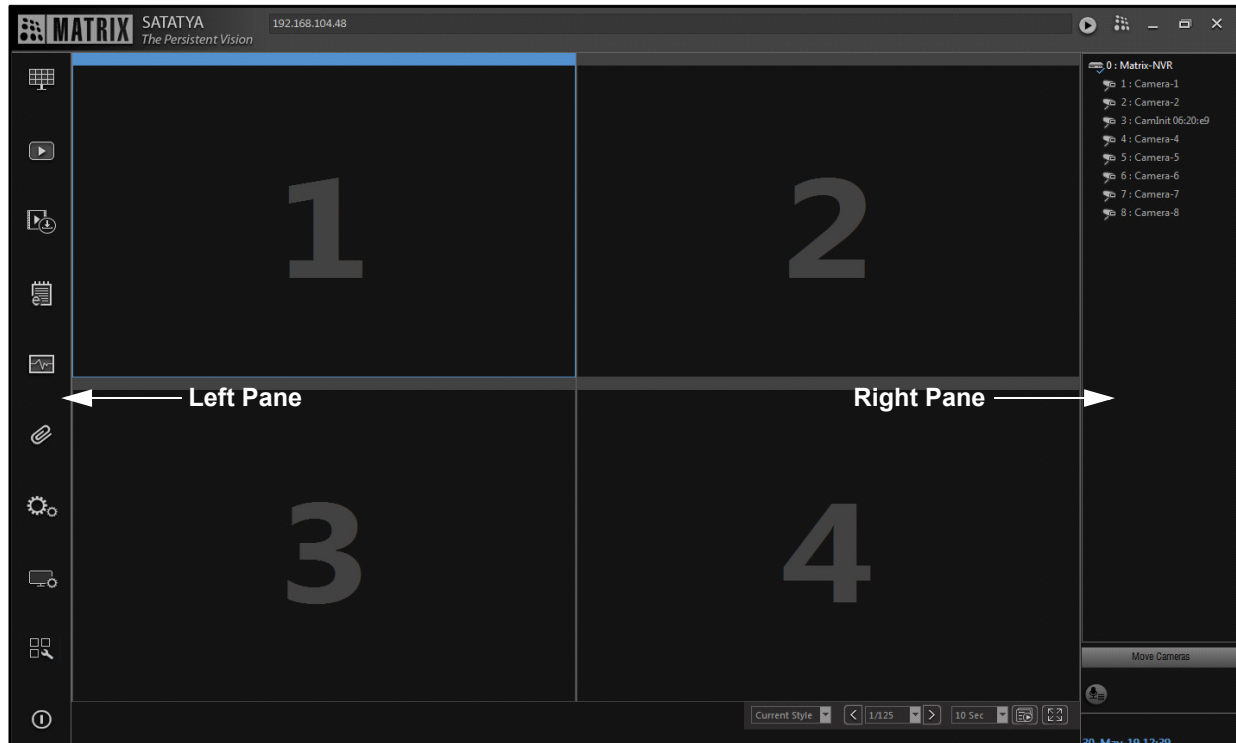

The Left Pane displays these options — Layout, Playback, Quick Backup, Event Log, Device Status, Manage, Device Configuration, Local Settings, Quick Backup and Logout.

The Right Pane displays all the channels as supported by the SATATYA Device. The additional options displayed are — Move Camera, Speak to Device and View Online Events.

Other SATATYA devices can be added to a particular SATATYA device, this is known as Cascading. Using this functionality, multiple cascaded devices can be monitored from a single SATATYA device. For more details, refer to [“Devices”](#).

For detailed configurations, refer to the respective topic.

About

Once you login, the Device Client Live View screen appears.

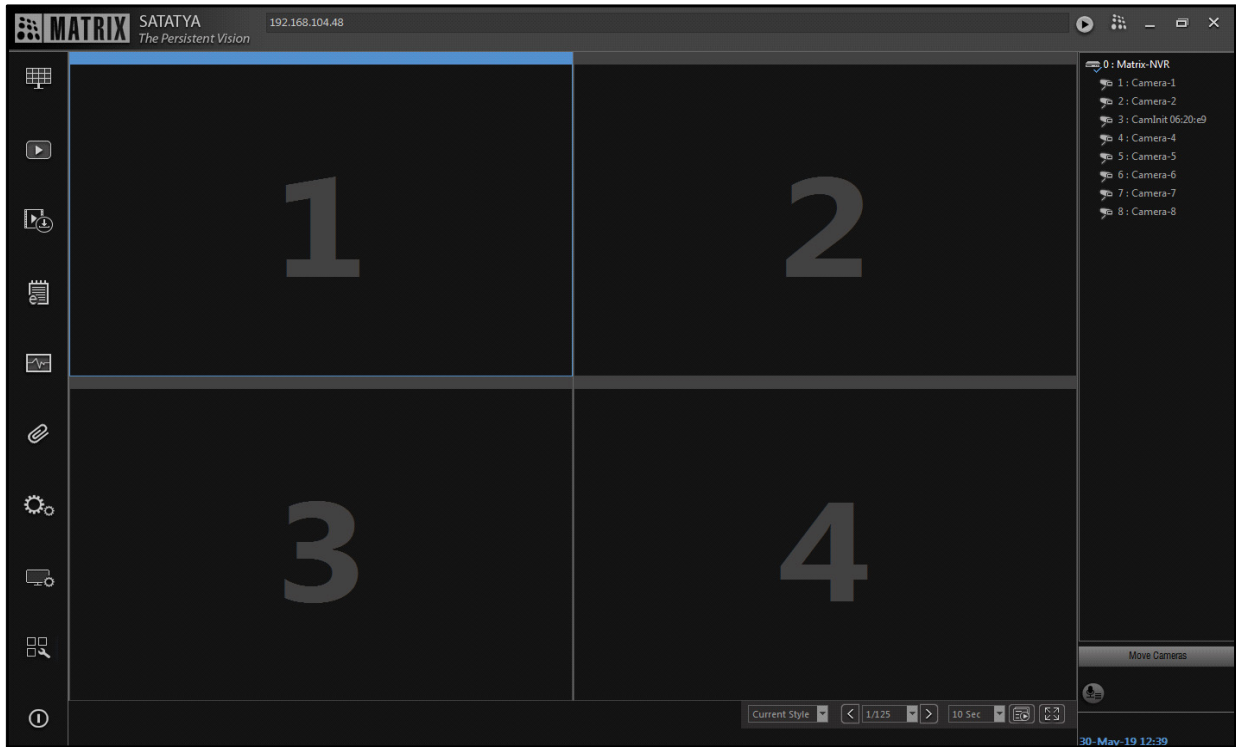

Click **About** . This option enables you to view details of the product, Version and Build Date-Time of Firmware as well as Device Client as follows:

For versions V8R6 and onwards

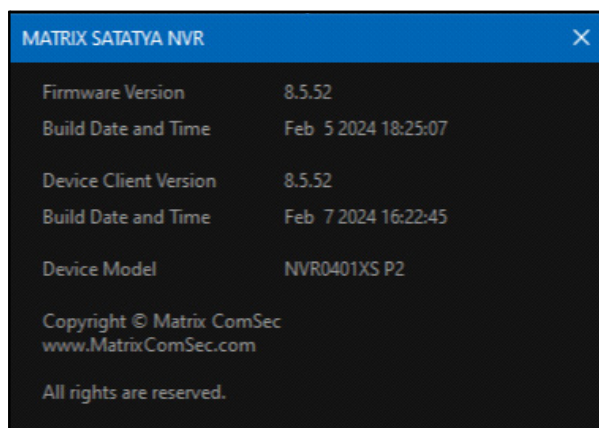

For versions V8R1 to V8R6



For version earlier than V8R1



Monitoring the Camera from left pane

The left pane of the home page displays the following options as shown.

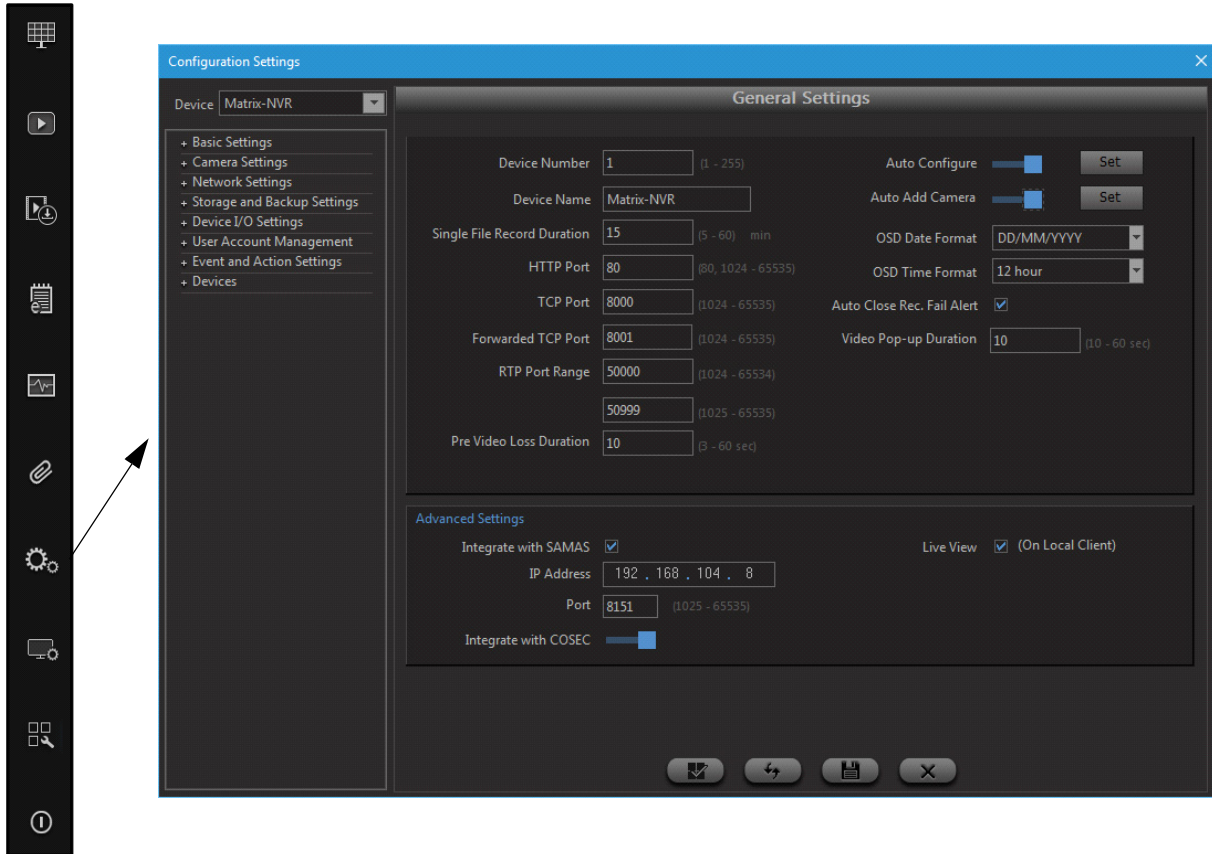

The camera list contains only those cameras whose access rights are given to the user. **E.g.:** If an admin creates a user named Jerry and gives him the access rights of four cameras from **Device Configuration > Configuration Settings > User Account Management > User Account** page. Then, only four cameras will be visible for Jerry. If the admin changes user rights in the running session, then it will take effect in the next time login only.

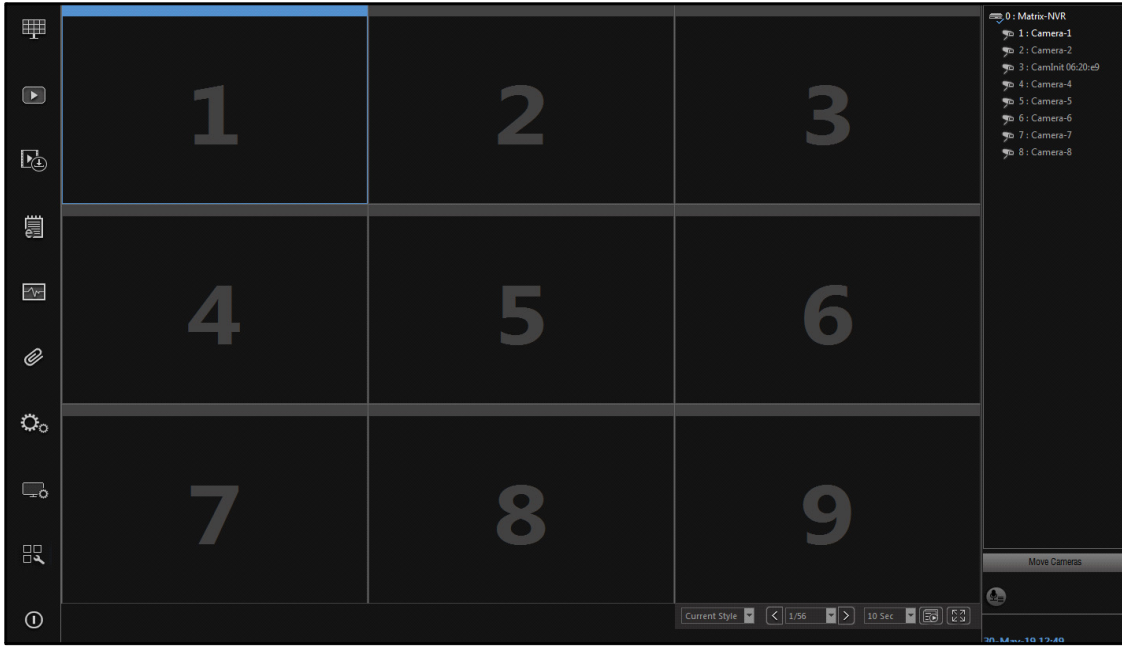

Live Video

The user has two options for viewing live video from the cameras in the monitoring windows of the center pane which are mentioned as below:

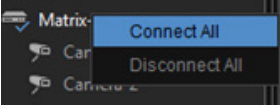
- Click on the **Connect All** option  and view live video from all the connected

cameras of the SATATYA device. For details see [“Move Cameras”](#). Also you can see the live view of selected cameras of the connected network devices.

- Click on the **Layout**  section in the left pane and view the desired cameras. For details see [“Layout”](#)
- Click on Move Cameras to move the camera from one device to another. For details see [“Move Cameras”](#)

Quick View

Quick View is a feature that enables a user to go to a particular camera directly without scrolling through a list of cameras. To do so, one needs to press Ctrl key and any Numeric key from the keyboard so that the Quick View feature gets enabled. The following screen appears as below.

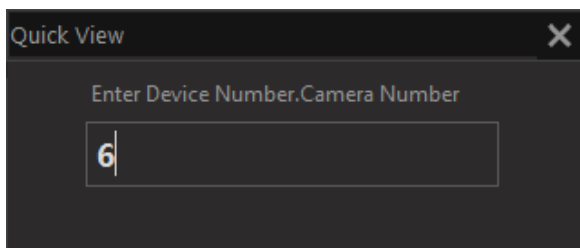

Now, enter the device number and camera number separated by “.” for which the quick view number is to be configured. **E.g.:** If 20.12 is entered, then the live view of camera number 12 of device number 20 will be displayed. Similarly, if 2 is entered, then the live view of camera number 2 of device number 0 (My Device) will be displayed.

Two Way Audio

Speak to Device

The two way audio feature enables to send audio from device client and play it on speaker connected to audio-out port of SATATYA device.



For NVRXS P2 series make sure the HDMI port is connected to a TV/Monitor with built-in speaker.

The person who wants to send his audio must connect Mic or any other Audio Input device to the computer having Device Client. Now login to the device client and click on **Speak to Device** icon.



You can select MY Device or any cascaded device to send audio to that device.

The Audio OUT port of SATATYA device can be connected to the speaker or HDMI port of device can be connected with local monitor. The Audio output will be received as per the priority set from Audio Settings.

Device Client will send audio data in some fixed chunk size every time based on audio out codec configuration.

Example1: If Audio is being played on local client of device, and user clicks on Speak to Device from Device client, then

- If Priority is Camera: Audio of camera in local will be continued and audio of device client will not be started.
- If Priority is Client: Audio of camera in local will be stopped and audio from device client will be started. In this you can speak on microphone connected to the computer with device client. Your voice will be sent to the device which can be heard on the speaker connected to the device.

Example2: If Audio of Camera1 is ON in device client of a device. The Audio of Camera2 is ON in local of device. When user clicks on Speak to Device from Device client, then

- If Priority is Camera: Audio of camera2 in local will be continued and audio of device client will not be started. Camera1 audio will be continued playing in device client.
- If Priority is Client: Audio of camera2 in local will be stopped and audio from device client will be started. Camera1 audio will be continued playing in device client.

Speak to Camera (Speak Now)



For NVRXS P2 series, *Speak Now* will not be accessible from the Local Client. However you can use the same from Device Client.

The two way audio feature enables to send audio signal from local/device client and play it on the in-built speaker of camera or any external speaker connected to the Camera output.



Supported camera models for Audio Out on Camera are: **Axis: M1031-W** (if added via ONVIF or Camera Initiation (Brand-Generic) only), **Matrix Professional Model Cameras, Matrix Ruggedized Cameras and Matrix OEM PTZ camera.**

The specific access rights must be given for audio out to the user.

Connect the Microphone to the computer where the Local/Device client is installed.

Device Client

Select the camera from the list to which the audio is to be sent. The toolbar of the camera will appear as shown below.

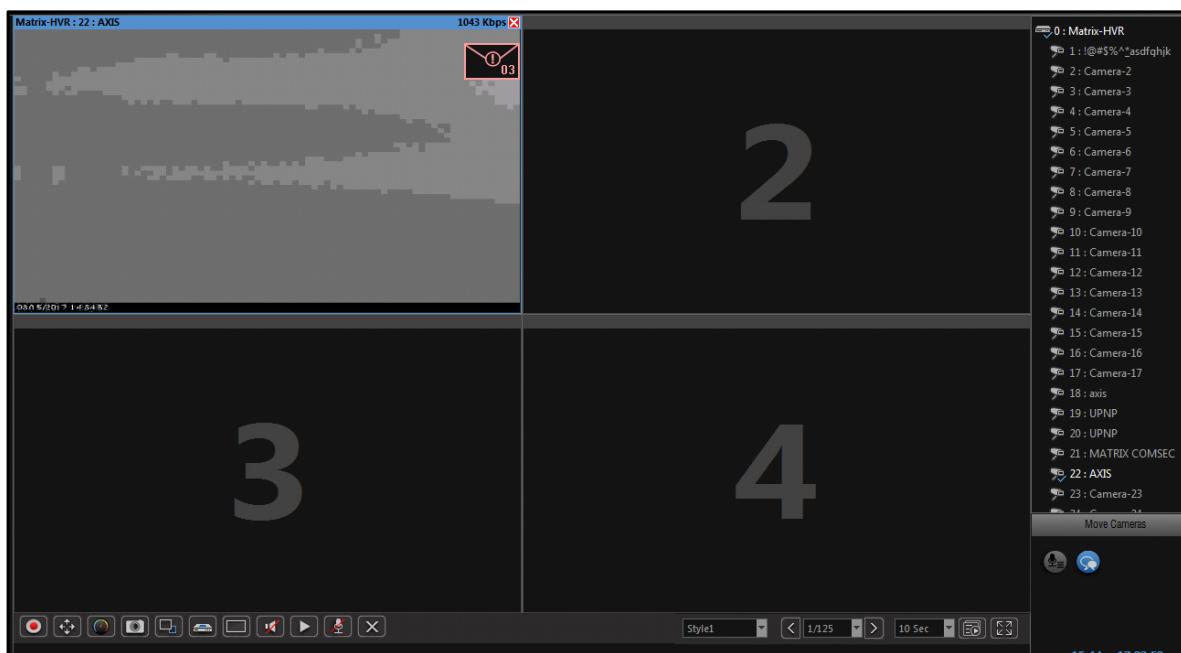

Now click the **Speak Now** button as shown below.

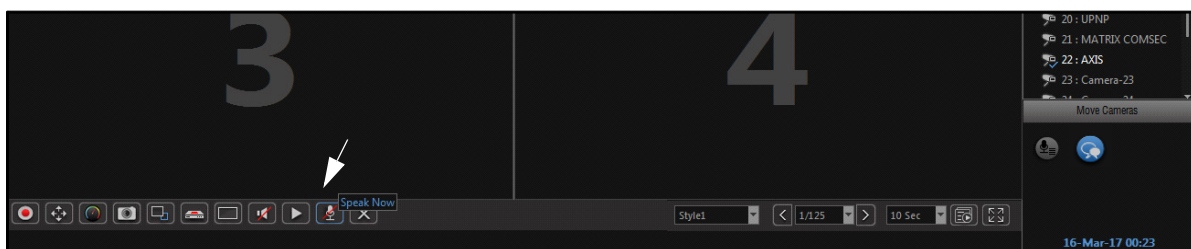

The Audio symbol will appear on the camera in the list as shown below. Now you can speak via microphone which will appear as output to the camera speaker.

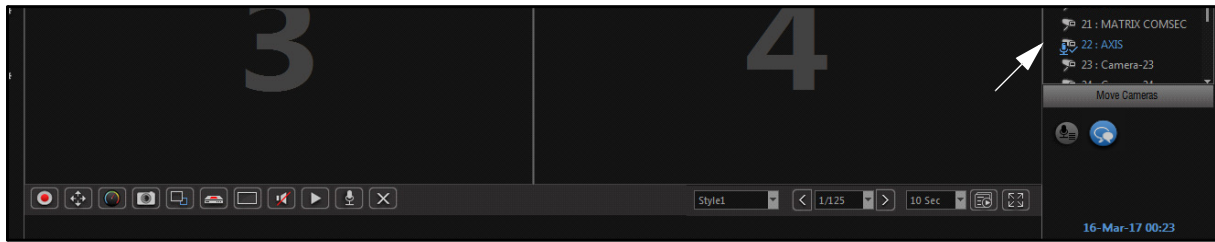

Local Client

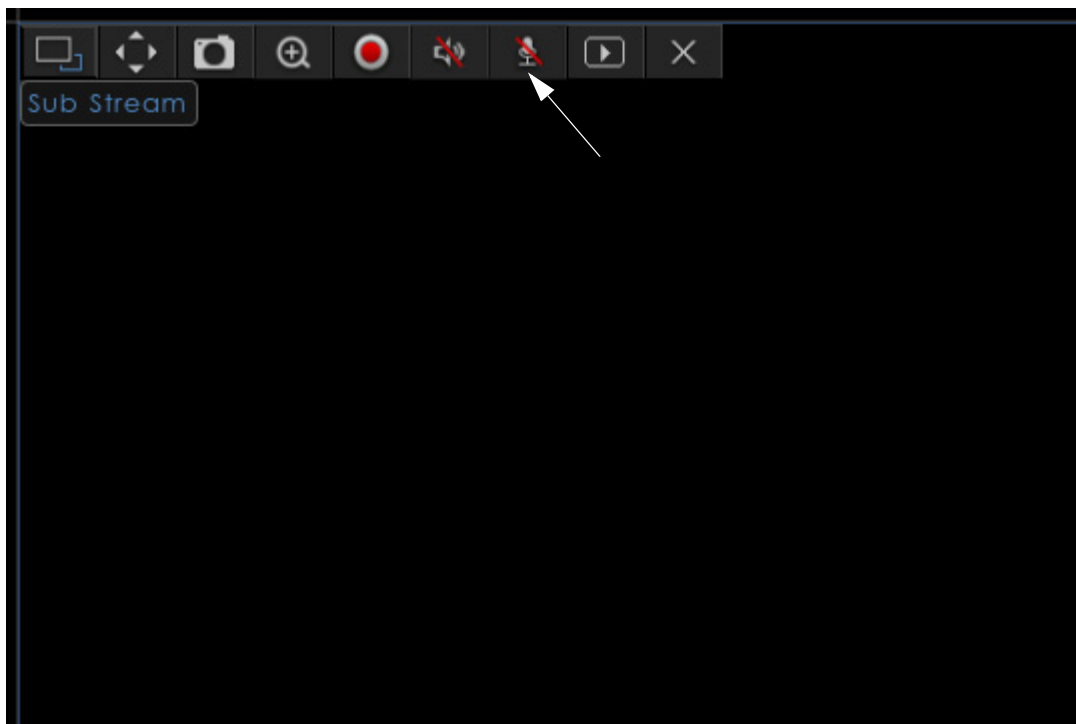

If Two way audio to device is ON and if Two way audio to camera is clicked, then sending audio to device will be stopped and camera audio will be started.

Assume camera audio is ON in device client and when device client sends audio to camera, then both audio will work simultaneously at device client.



The Two way audio is applicable only for G.711 codec.

View Online Events

When the live event occurs on the SATATYA device, it is notified by displaying icon at the right panel in Device Client as shown below.

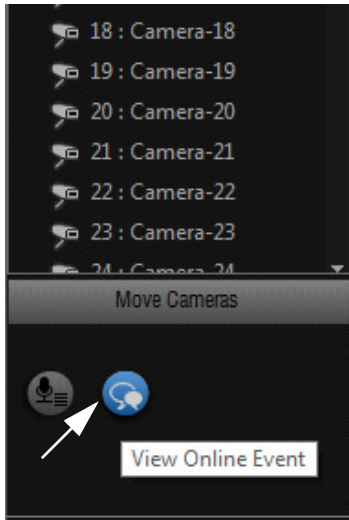

On clicking this icon, **Event Notification** window appears as shown below. Here the Live events are displayed.

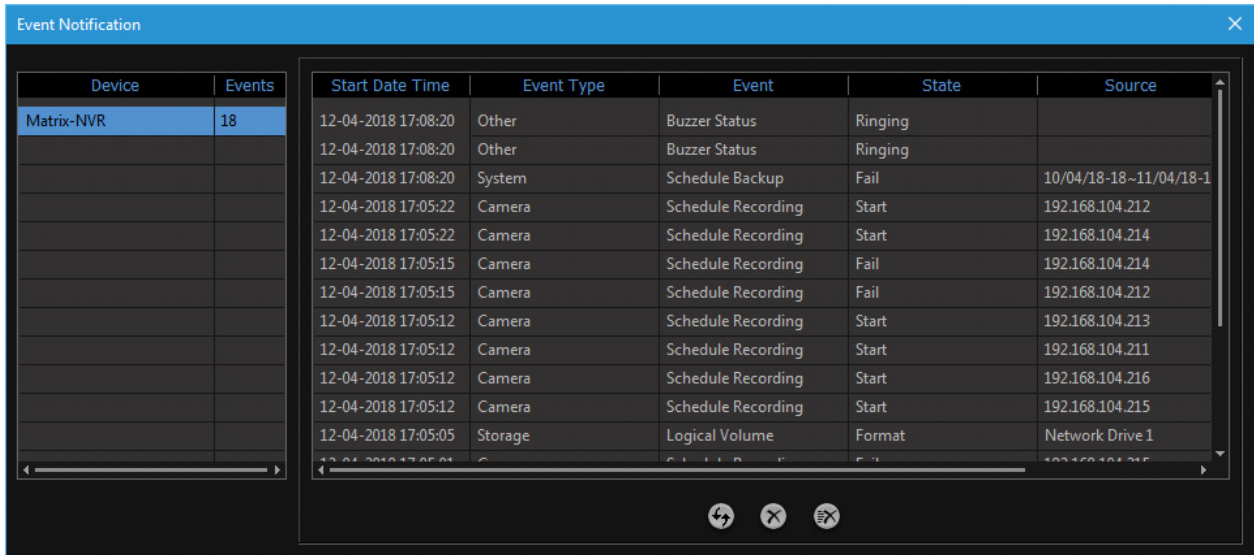

Refresh: Click on this button to relist all the live events of the selected device.

Clear: Click on this button after selecting the events to be cleared. Only the selected events will be cleared.

Clear All: Click on this button to clear all the events displayed on the grid.

The **Live Events** icon in the Device Client disappear only after clearing all the events on the page and then closing the window using cross button at the top.

The left pane of Device Client has following controls. Click on link for the detailed explanation.

["Layout"](#)

["Playback"](#)

["Quick Backup"](#)

“Event Log”

“Device Status”

“Manage”

“Device Configuration”

“Local Settings”

“Quick Setup”

“Logout”

Layout

Click on **Layout** section from the Left pane of device client. The layout window appears as shown below.

Select a layout template from the different options. The selected layout will be applied in the monitoring window.

Select the style to save the layout from the **Save Layout As** drop-down list. You can select one of the five styles from the list.

Enable **Set As Default** check box to set the selected layout as default layout.

Click **Save** to save the style.

Once done the layout gets stored and when the user logs out and logs in again to the device client he finds the same layout which was selected before. Thus, user specific layouts can be created and stored.

Now, assign cameras to the monitoring windows in the selected layout by highlighting a monitoring window and clicking on the appropriate channel.

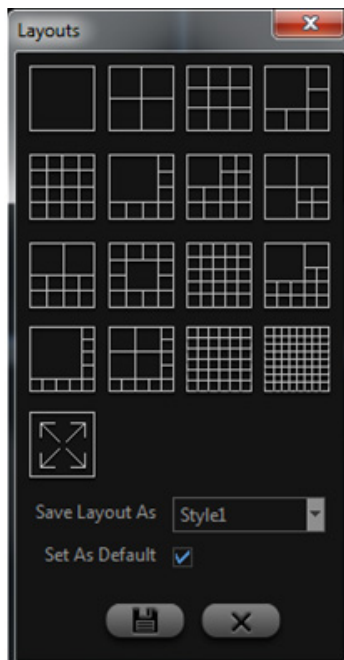

E.g. If cameras are to be saved along with the layout, then first assign the cameras to the monitoring window and then click on Layouts option from the left panel and the following screen appears.

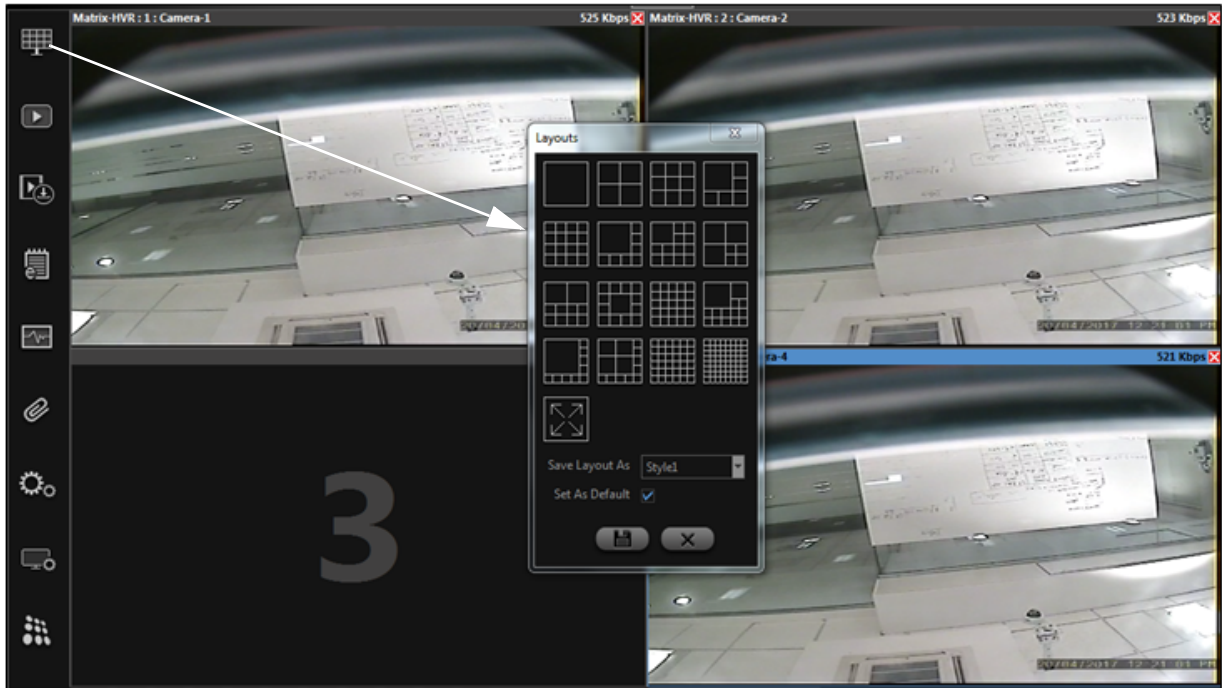

- Select the layout from the different templates.
- Select style from the **Save Layout As** drop-down list.
- Enable **Set As Default**, if the layout is to be set as default layout.
- Click **Save** and then close the pop-up window.

Now, when the user logs out of the device client and then logs in again, same layout with the assigned cameras will be displayed.

Click on the Full Screen  icon from the layout window to view the display screen in the full screen mode. You can also achieve the full screen mode by clicking the icon located at the bottom right corner of the screen.

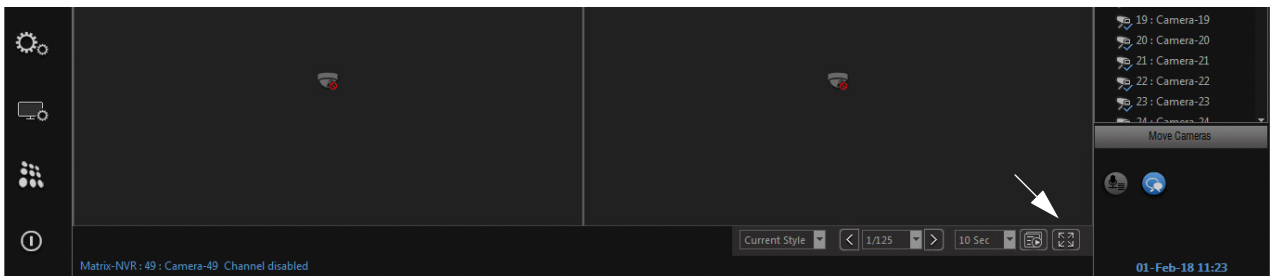

To exit the full screen mode, right click anywhere on the display screen and select **Exit Full Screen** as shown below.

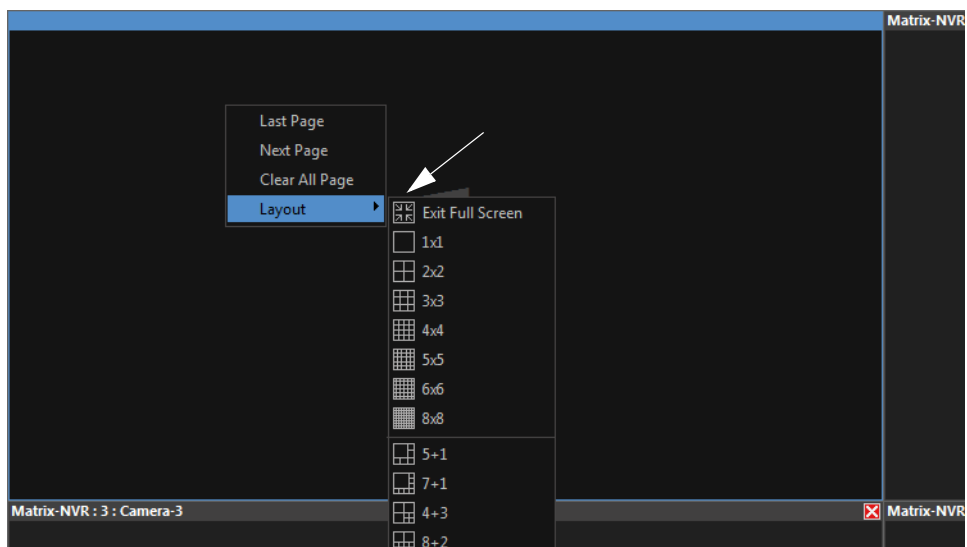

Playback

Click on **Playback** icon from the Left pane of device client. The Playback window appears as shown below.

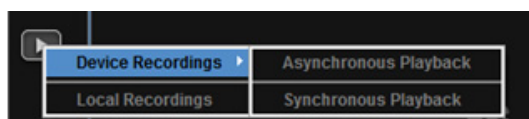

For more details on Asynchronous and Synchronous Playback, [See “Search and Playback” on page 153.](#)
To know about Local Recordings, [See “Local Recordings” on page 170.](#)

Quick Backup

Quick Backup is a feature that enables the operator to get the backup of the desired camera from the Live View page itself easily and quickly.

To do so, click on **Quick Backup** icon from the Left pane of device client and the following pop-up window appears as shown below.

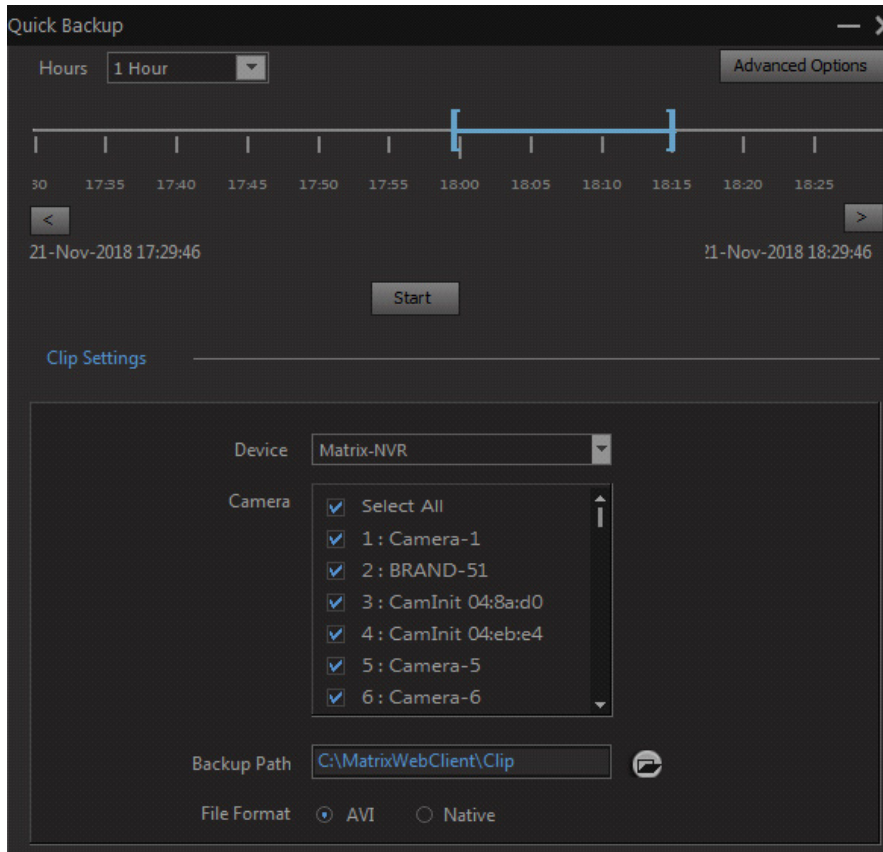

Using the **Timeline**, select the duration till which the backup is to be taken.



- 1) Backup can be taken maximum of 3 days and minimum of 5 minutes.
- 2) The default selection of timeline is 15 minutes.
- 3) **Native** file format is not applicable for Local Client in NVRX/NVRX P2 series.

Advanced Option

Advanced Option allows you to configure Duration and Star/End Date Time for the backup action in the customized way.

Click on the **Advanced Options** and the Backup Management Settings page appears as shown below.

From here you can configure parameters for the Manual Backup. For more information on backup configuration, [See “Backup Management” on page 324.](#)

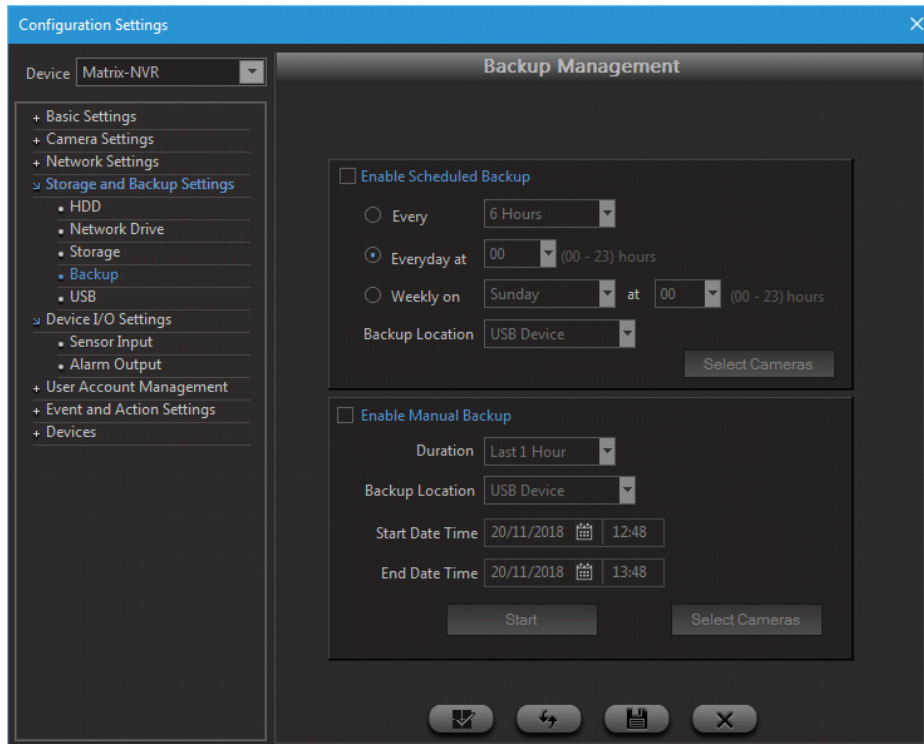

Clip Settings

Clip Settings allows to configure following parameters for taking backup of the required device, cameras and storage location.



The Clip Settings configurations are independent from Manual Backup configurations.

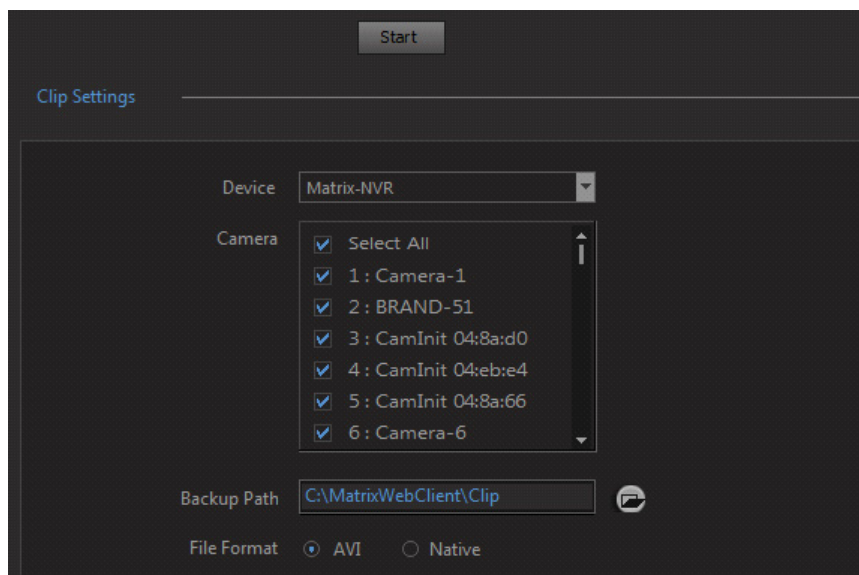

Device: Select the device for which the backup is to be taken from the drop-down list.

Camera: Select the check boxes for the cameras for which the backup is to be taken from the list.

Backup Path: Select the path using **Browse** button at which the backup is to be stored. One can also specify the path of attached USB. This is applicable to Device Client.

Backup Location: For **Local Client** select the option in which the backup is to be stored. The options are: USB Drive, Network Drive 1 and Network Drive 2.

File Format: Select the format in which the backup is to be taken from AVI and Native option.

Once these settings are done, click **Start** button and the following screen appears.

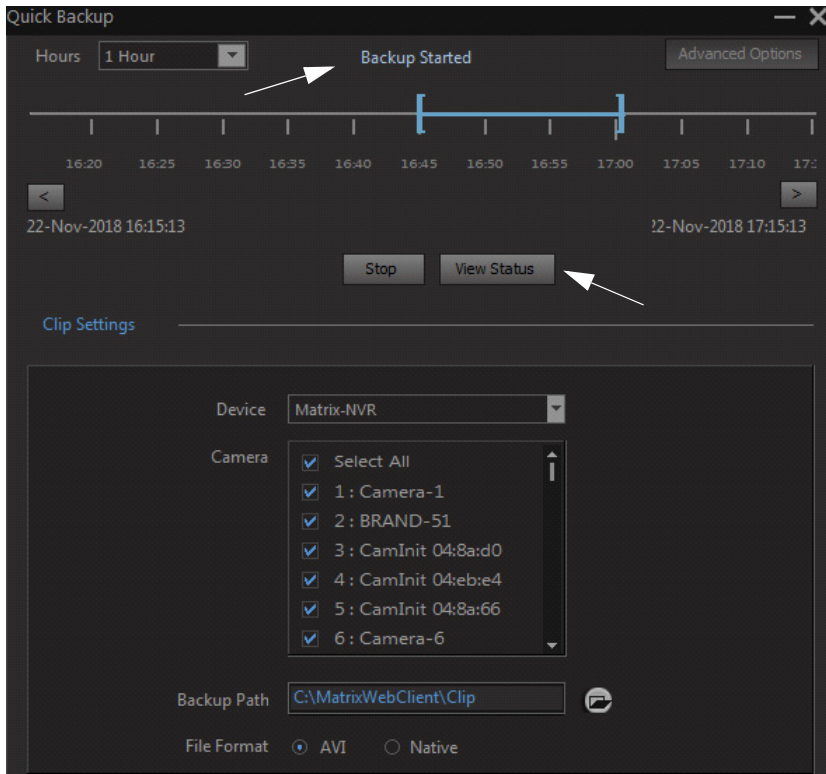

When the process of taking backup begins, the message “**Backup Started**” appears as shown in the screen above.

Now, when the backup is in progress and the pop-up window is minimized, the color of the Quick Backup icon gets changed to blue indicating the ongoing backup process.

You can also click **View Status** button to view the status of backup being taken as shown in the screen below.

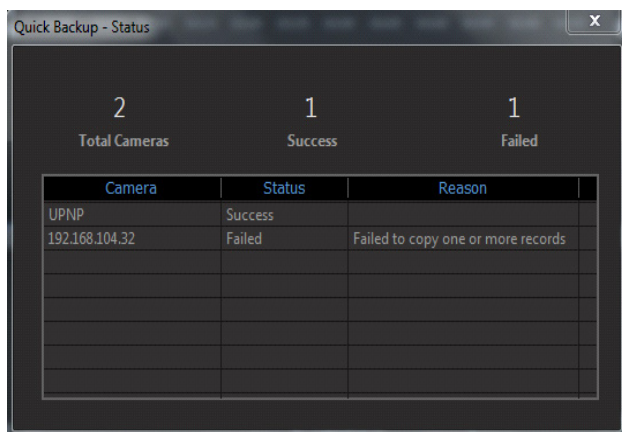

The status pop-up window displays the total number of cameras for which the backup is being taken along with their success and failure status as shown in the above screen.

Event Log

Click on **Event Log** section from the Left pane of device client. The Event Log page appears.

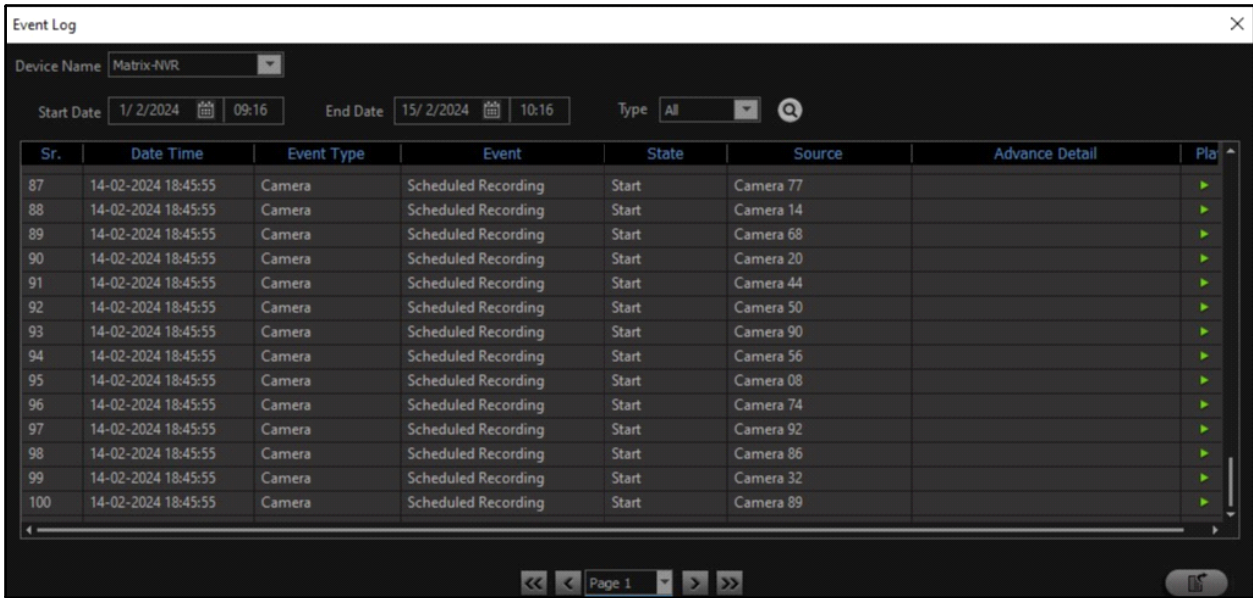

The screenshot shows the 'Event Log' window for a 'Matrix-NVR' device. The interface includes filters for 'Start Date' (1/ 2/2024 09:16), 'End Date' (15/ 2/2024 10:16), and 'Type' (All). The main table displays the following data:

Sr.	Date Time	Event Type	Event	State	Source	Advance Detail	Pla
87	14-02-2024 18:45:55	Camera	Scheduled Recording	Start	Camera 77		▶
88	14-02-2024 18:45:55	Camera	Scheduled Recording	Start	Camera 14		▶
89	14-02-2024 18:45:55	Camera	Scheduled Recording	Start	Camera 68		▶
90	14-02-2024 18:45:55	Camera	Scheduled Recording	Start	Camera 20		▶
91	14-02-2024 18:45:55	Camera	Scheduled Recording	Start	Camera 44		▶
92	14-02-2024 18:45:55	Camera	Scheduled Recording	Start	Camera 50		▶
93	14-02-2024 18:45:55	Camera	Scheduled Recording	Start	Camera 90		▶
94	14-02-2024 18:45:55	Camera	Scheduled Recording	Start	Camera 56		▶
95	14-02-2024 18:45:55	Camera	Scheduled Recording	Start	Camera 08		▶
96	14-02-2024 18:45:55	Camera	Scheduled Recording	Start	Camera 74		▶
97	14-02-2024 18:45:55	Camera	Scheduled Recording	Start	Camera 92		▶
98	14-02-2024 18:45:55	Camera	Scheduled Recording	Start	Camera 86		▶
99	14-02-2024 18:45:55	Camera	Scheduled Recording	Start	Camera 32		▶
100	14-02-2024 18:45:55	Camera	Scheduled Recording	Start	Camera 89		▶

The Matrix SATATYA Devices have the capability to store up to 10000 events logs. The following types of event logs are generated by the system:

- Camera Events
- Sensor events
- Alarm Events
- System events
- Storage Events
- Network Events
- Other Events
- User Events
- Cossec Events
- Image Upload Events



Alarm Events and Sensor Events are not applicable to NVRXS P2 Series.

The maximum logs displayed per page as per the set Date/Type filter is 100.

Select the device from the **Devices** list.

Select the **Start Date** using the calendar button to specify the Start Date from which Event Log is to be generated.

In **Start Time**, enter the time in HH:MM format to specify the Start Time from which Event Log is to be generated.

Select the **End Date** using the calendar button to specify the End Date till which Event Log is to be generated.

In **End Time**, enter the time in HH:MM format to specify the End Time till which Event Log is to be generated.

Select the Event **Type** from the drop-down list.

Click the **Search** button.

The relevant event logs fulfilling the filter criteria will be displayed in the **Event List** Grid. Only 100 Event Logs will be displayed on each page. Click on the Page drop-down list to select the desired page or click on Page navigation buttons to view the event logs.

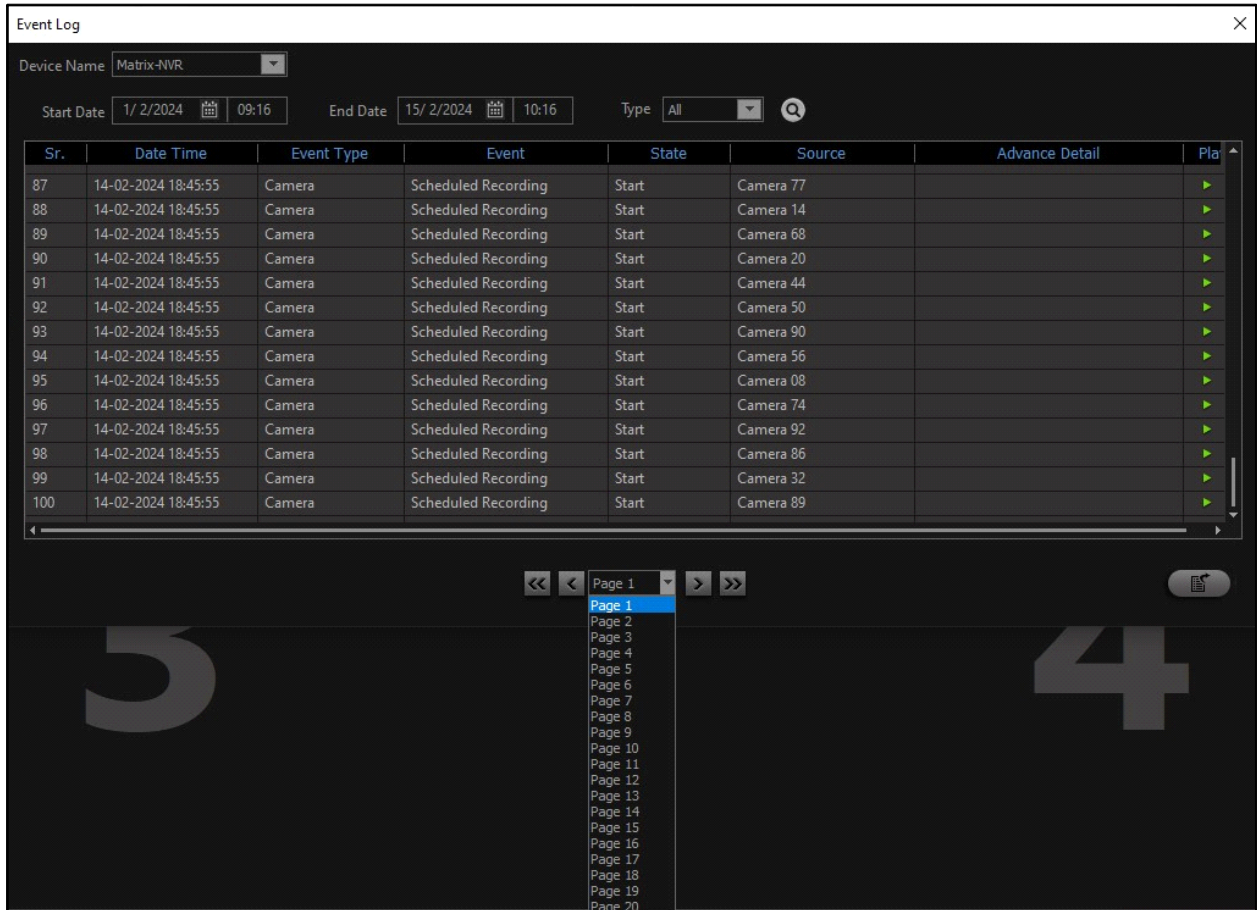

The screenshot shows the 'Event Log' window with the following details:

- Device Name: Matrix-NVR
- Start Date: 1/ 2/2024 09:16
- End Date: 15/ 2/2024 10:16
- Type: All

Sr.	Date Time	Event Type	Event	State	Source	Advance Detail	Pla
87	14-02-2024 18:45:55	Camera	Scheduled Recording	Start	Camera 77		▶
88	14-02-2024 18:45:55	Camera	Scheduled Recording	Start	Camera 14		▶
89	14-02-2024 18:45:55	Camera	Scheduled Recording	Start	Camera 68		▶
90	14-02-2024 18:45:55	Camera	Scheduled Recording	Start	Camera 20		▶
91	14-02-2024 18:45:55	Camera	Scheduled Recording	Start	Camera 44		▶
92	14-02-2024 18:45:55	Camera	Scheduled Recording	Start	Camera 50		▶
93	14-02-2024 18:45:55	Camera	Scheduled Recording	Start	Camera 90		▶
94	14-02-2024 18:45:55	Camera	Scheduled Recording	Start	Camera 56		▶
95	14-02-2024 18:45:55	Camera	Scheduled Recording	Start	Camera 08		▶
96	14-02-2024 18:45:55	Camera	Scheduled Recording	Start	Camera 74		▶
97	14-02-2024 18:45:55	Camera	Scheduled Recording	Start	Camera 92		▶
98	14-02-2024 18:45:55	Camera	Scheduled Recording	Start	Camera 86		▶
99	14-02-2024 18:45:55	Camera	Scheduled Recording	Start	Camera 32		▶
100	14-02-2024 18:45:55	Camera	Scheduled Recording	Start	Camera 89		▶

Below the table is a page navigation dropdown menu showing 'Page 1' selected, with options for Page 2 through Page 20. Navigation buttons (back, forward, search) are also visible.

Click **Play** if you wish to view the playback.



The latest occurred events, falling under the search criteria entered in the filter will be displayed on the top of the page.

The Event Logs can be exported in text or excel format. Click **Export** to export the Event Logs.

Device Status

The system status page enables the user to view the current status of the various functionalities and components as configured from the system.

In order to access this functionality, click on the **Device Status** icon from the Toolbar of Local Client or from the Left Pane of Device Client. The Device Status window appears in device client as shown below:

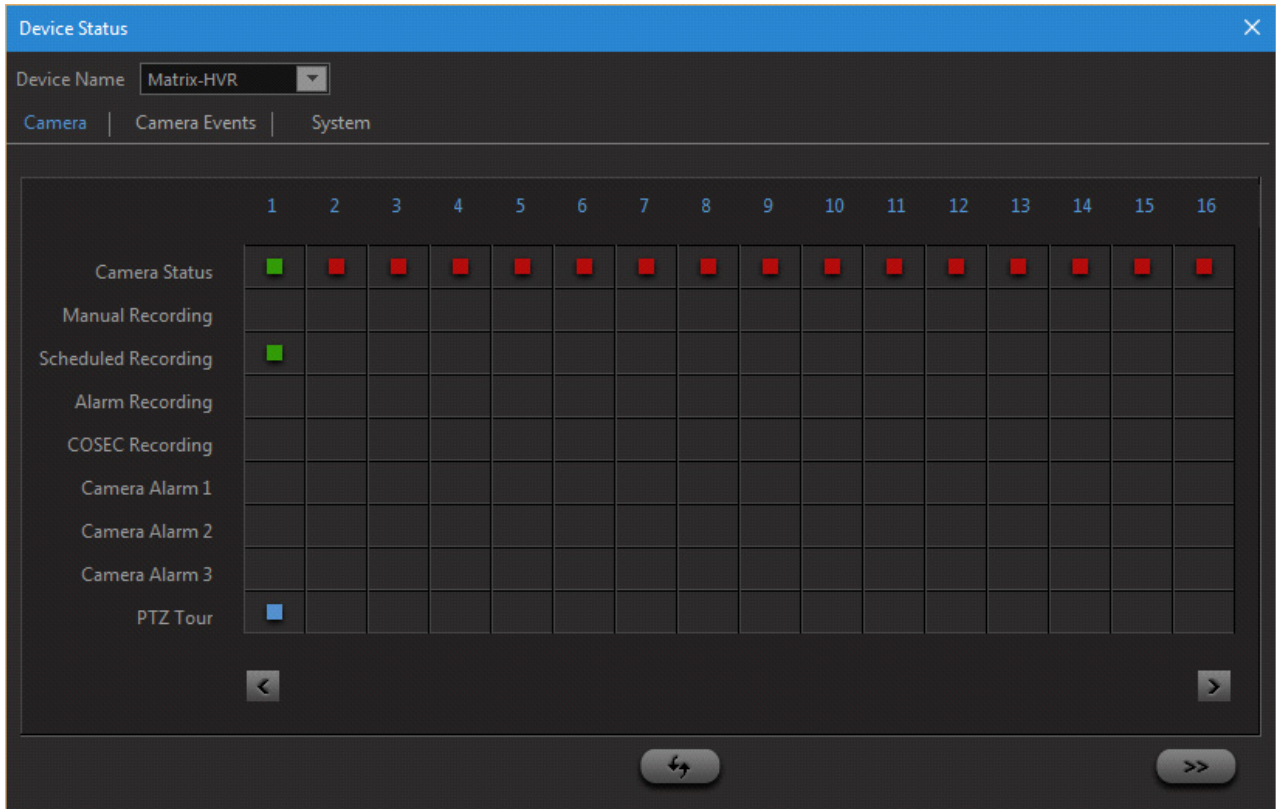

Camera

This page displays the status of the different components of camera listed in the left column as shown. Select a device from the **Devices** list whose status is to be viewed.

In the event of any of these functionalities being enabled on any of the channels, an appropriate icon is displayed in the grid against the respective channel and the functionality. An example is shown in the screenshot below.

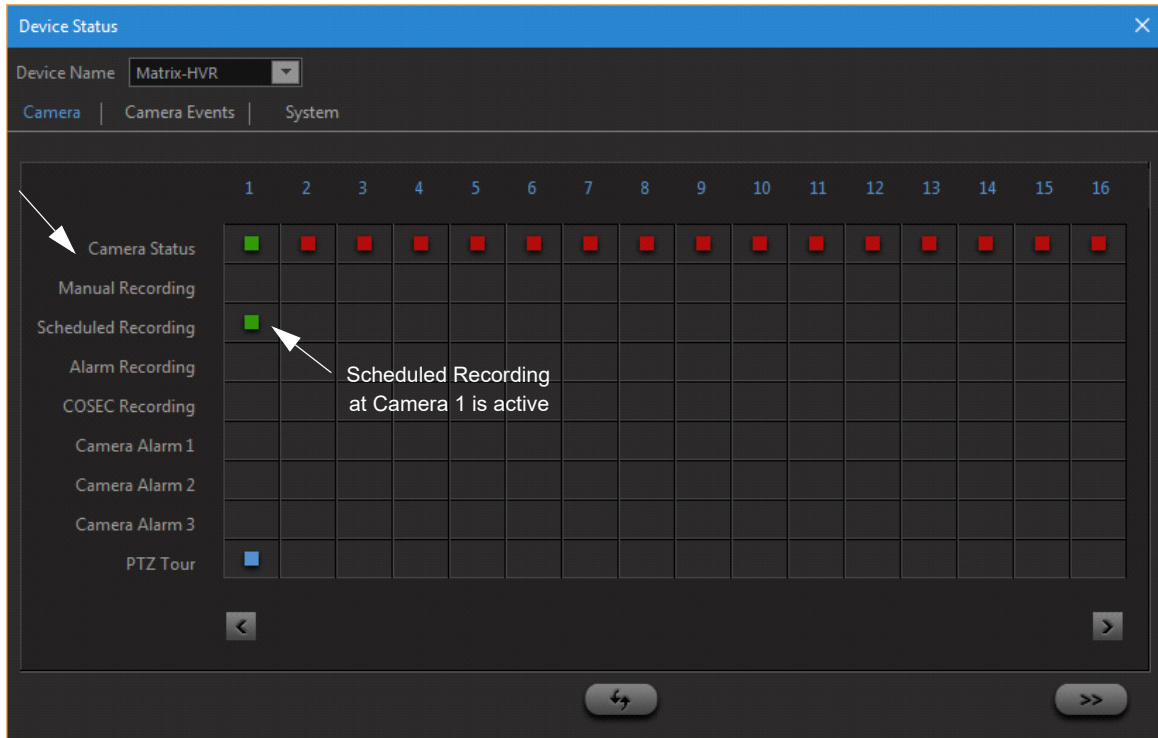

Click on **Next** and **Previous** arrows to view the status of other cameras.

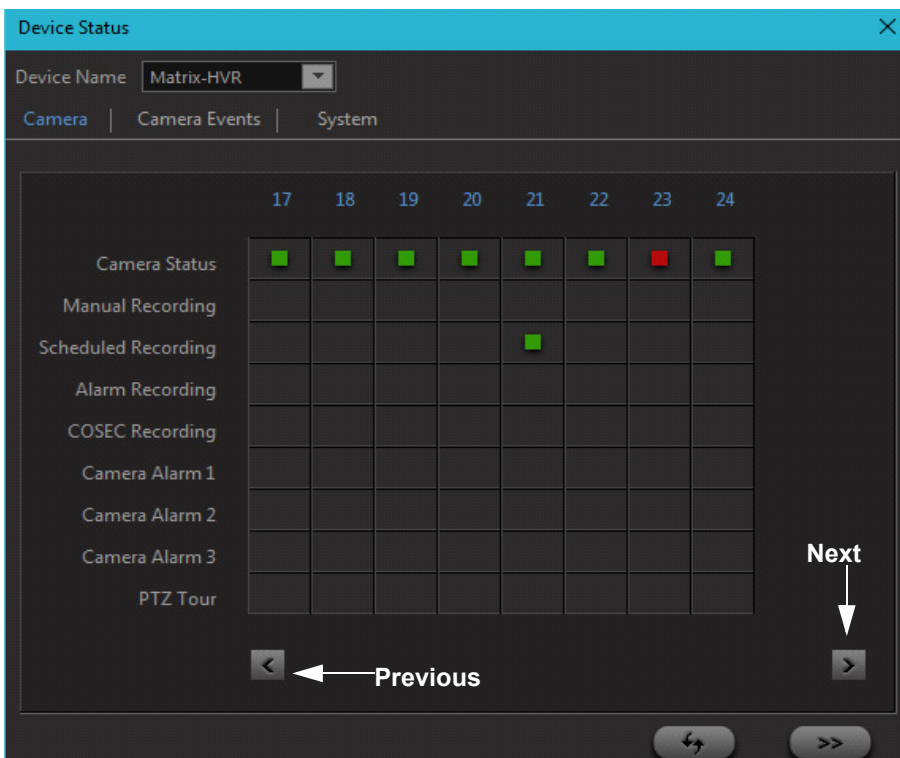

Camera Events

This page displays the status of the different events received from the camera. The events like Motion/No Motion Detection, View Tampering, Trip Wire etc. are listed in the left column as shown. Select a device from the **Devices** list whose Camera Events status is to be viewed.

In the event of any of these functionalities being enabled on any of the channels, an appropriate icon is displayed in the grid against the respective channel and the functionality.

Click on **Next** and **Previous** arrows to view the status of other cameras.

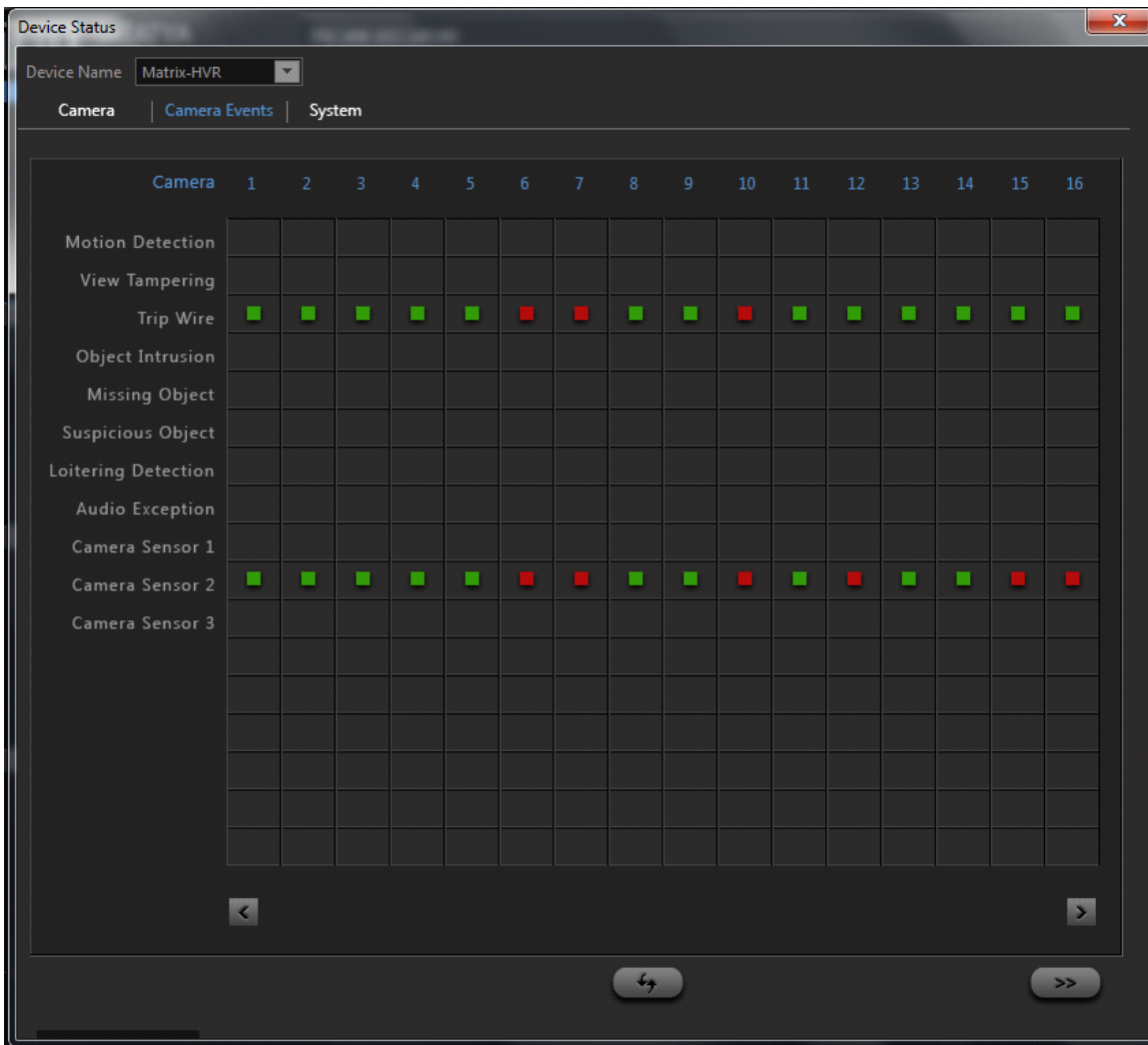

System

The **system** tab displays the status of the individual components like sensor inputs, alarm outputs, Hard Disks etc. as shown below:



Sensor Input and Alarm Output are not applicable to NVRXS P2 Series.

Select the device from the **Devices** list whose System status is to be viewed. The green box indicates that the component is enabled.

The Number of ports of Sensor Input and Alarm Output will be displayed as per the selection of the device variant.

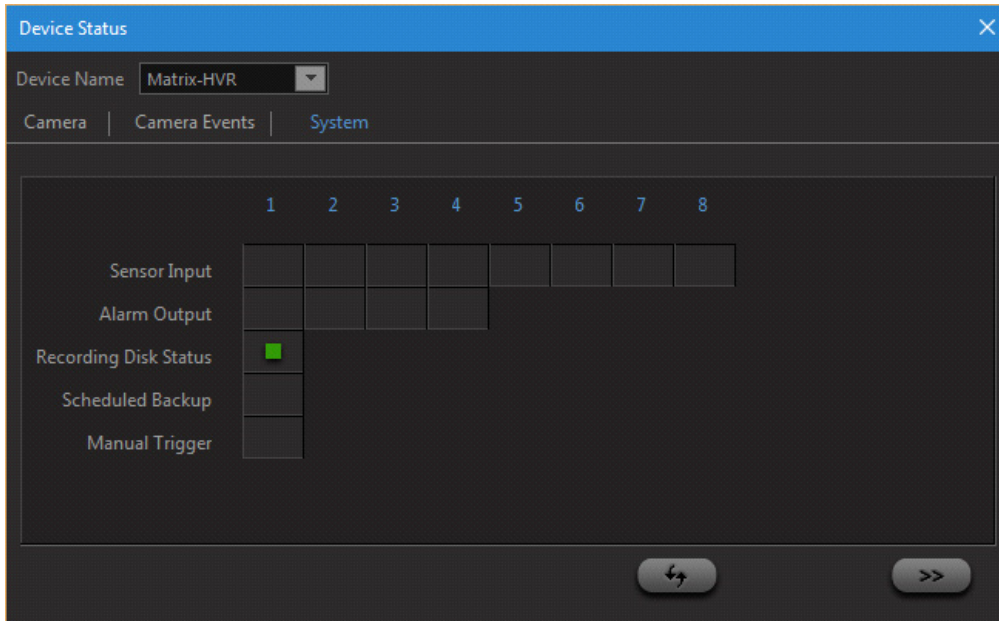

Advance Details

Click on the **More**  button to view the Advance details of Camera and System. The Advance Details page appears.

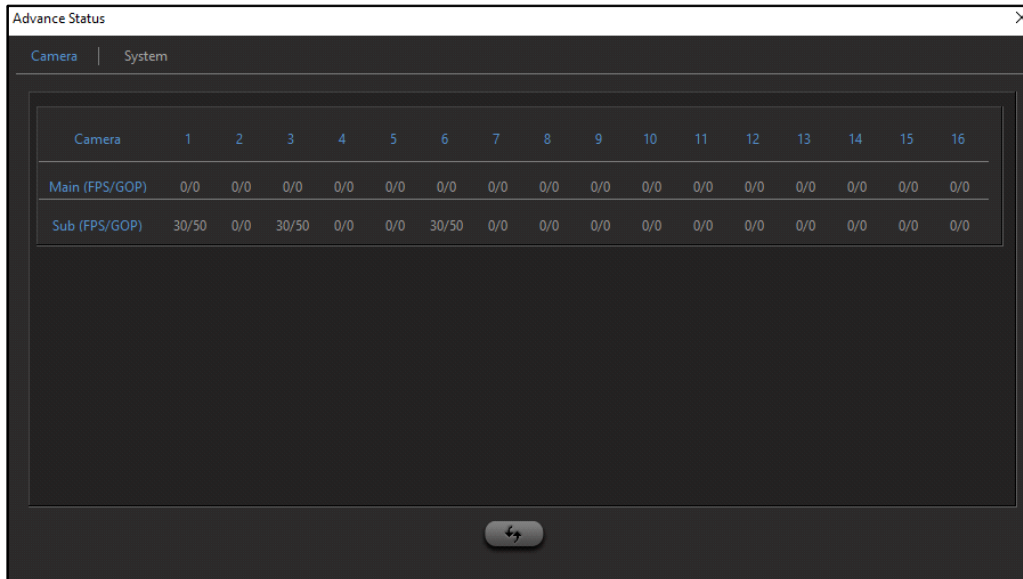

By default the **Camera** tab appears.

FPS: The Frame Rate per Seconds for individual Camera Channels is displayed for Main Stream and Sub Stream.

GOP: The Group of Picture, that is, the ratio of P Frame and I Frame is displayed for Main Stream and Sub Stream.



The FPS and GOP are displayed for individual camera channels for Main and Sub Stream in NVRX/NVRX P2 series only.

Click the **System** tab.

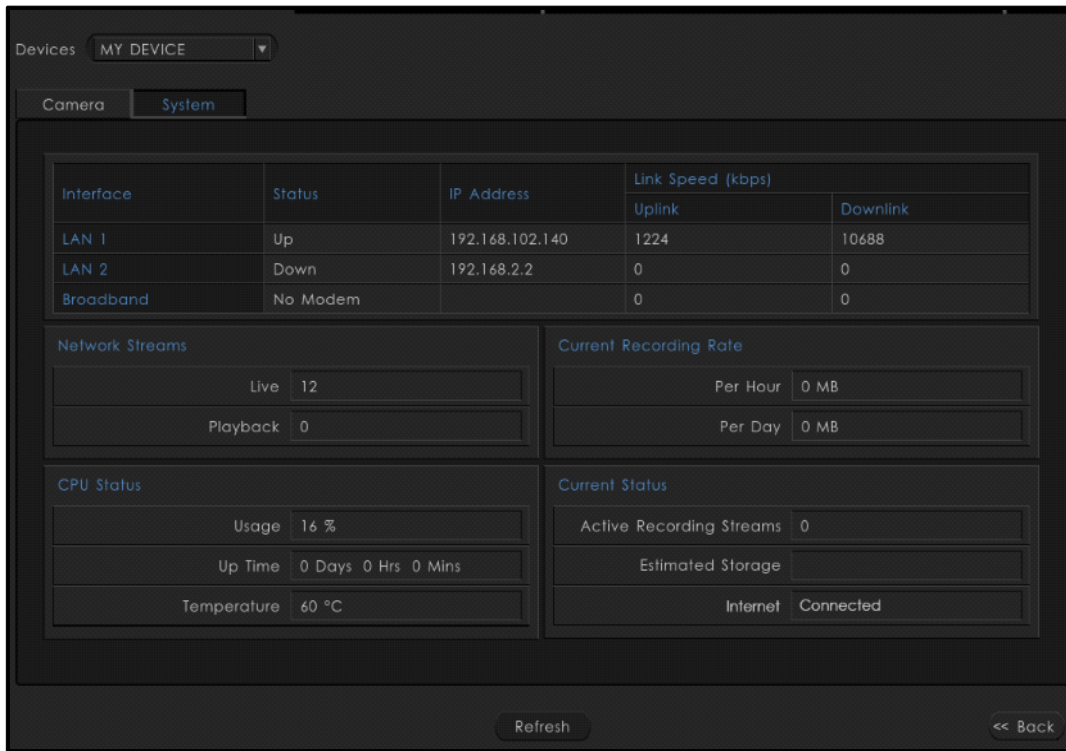

Interface

LAN1: The Status of LAN1 as Link up (connected) or Link down (not connected) is displayed in **Status** field. The **IP Address** of LAN1 is shown. The Network Load of transmitter and receiver in kbps is shown in **Uplink Speed** and **Downlink Speed** fields.



LAN 1 here also refers to LAN in HVR4 channel.

LAN2: The Status of LAN2 as Link up or Link down is displayed in **Status** field. The **IP Address** of LAN2 is shown.

The Network Load of transmitter and receiver in kbps is shown in **Uplink Speed** and **Downlink Speed** fields. To know about the throughput of each device, [See “Technical Specification” on page 364.](#)

Broadband: The Modem connection status whether Connected or Not is shown in **Status** field. The **IP Address** of Broadband connection is shown.

System

CPU Usage: The percentage usage of CPU or the CPU Load is shown here.

Up Time: The HVR Up Time i.e the days for which HVR is ON is shown in Days, Hours and Minutes format.



*In NVRX Series variant, **CPU Usage** and **Up Time**, **CPU Temperature** of the connected devices is displayed. The screen below displays the **Advance Status** screen in NVRX series variant.*



CPU Temperature Indication at High Temperature.

User will be notified with the help of buzzer when the CPU temperature of the system reaches to 100 degree Celsius. It will continue ringing till 105 degree Celsius after which the system will get shutdown.

To know more about the Buzzer status, [See "NVRX / NVRX P2 LED And Buzzer State" on page 17.](#)

The buzzer will be stopped automatically when the temperature drops from 100 degree Celsius. The buzzer can also be stopped manually by clicking the buzzer icon on the toolbar that appears when the event is triggered. You can see that in the figure below.

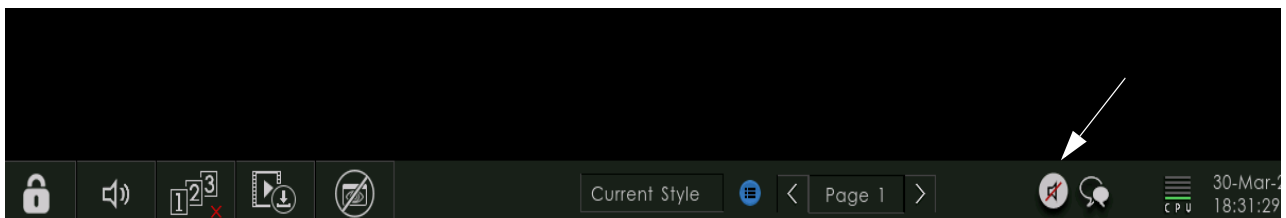

Network Streams

Live: The number of Live Streams being played from HVR are shown here.

Playback: The number of Playback Streams from HVR are shown here.

Current Status

Active Recording Streams: The number of Active Recording Streams being played from HVR are shown here.

Estimated Storage: The estimated storage time of HVR is shown here.

Current Recording Rate

Per Hour: The current recording rate per hour in MB is shown here.

Per Day: The current recording rate per day in MB is shown here.

Manage

Click on **Manage** section from the Left pane of device client. The window appears as shown below.

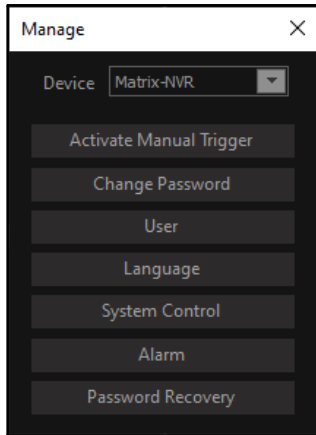

*The **Password Recovery** tab is applicable for NVRX/NVRX P2 series only.*

Active Manual Trigger

This option enables the user to trigger the outputs related to the Manual Trigger event as configured from the Event and Action option of the Device Configuration page. The button toggles between **Activate** and **Deactivate** based on the current status of the Manual Trigger.

Change Password

This option allows the user, who is currently logged in to change the password for accessing the web Jeeves application. By clicking on Change Password, the following page appears.

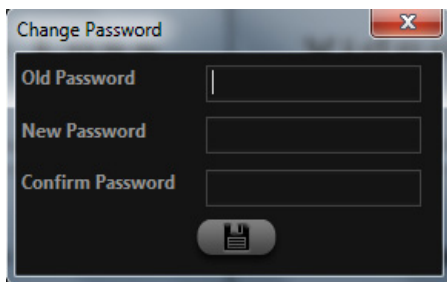

Enter the Current Password in the **Old Password** field and then enter a unique password in the **New Password** field. Reenter the new Password in the **Confirm Password** field. Click on the **Submit** icon to change the Password.

Users

This option enables the user to view the online users as well block some of the online users as and when required. The user can also unblock the previously blocked users. By clicking on Users, the following page appears.



The screenshot shows a window titled 'Online Users' with a close button (X) in the top right corner. The window contains a table with three columns: 'User Name', 'User Group', and 'IP Address'. Each row has a checkbox in the first column. The table lists five users: 'admin' (Admin, 192.168.103.46), 'operator' (Operator, 192.168.102.87), and three instances of 'samir' (Admin, with IP addresses 192.168.102.45, 192.168.102.45, and 192.168.102.71). Below the table is a navigation bar with left and right arrow buttons, a 'Page 1' dropdown menu, and two circular icons: a power button and a lock icon.

<input type="checkbox"/>	User Name	User Group	IP Address
<input type="checkbox"/>	admin	Admin	192.168.103.46
<input type="checkbox"/>	operator	Operator	192.168.102.87
<input type="checkbox"/>	samir	Admin	192.168.102.45
<input type="checkbox"/>	samir	Admin	192.168.102.45
<input type="checkbox"/>	samir	Admin	192.168.102.71

Select the logged in users to block by checking the boxes against the relevant entries in the list and click on the

Block button . Select all the users by checking the box located next to the column name.

Click on the **View Blocked Users** button  to view the currently blocked users. Select the users to be blocked by checking the boxes against the relevant entries in the list and click on the **Unblock** button. Select all the users by checking the box located next to the column name headers.

Language

This option enables user to change the default language of SATATYA NVRX/NVRX P2. You can also configure the required languages through the device client and, make it as a default language for both Device as well as Local client.

For this, .CSV file is to be maintained at where the particular Language data will be stored. User can download (export) the file from Device Client itself.



Only the Admin Group users can configure the Language.

Language feature is available only for SATATYA NVRX/NVRX P2 variants.

Click on the **Language** button and a pop-up will open as shown below.

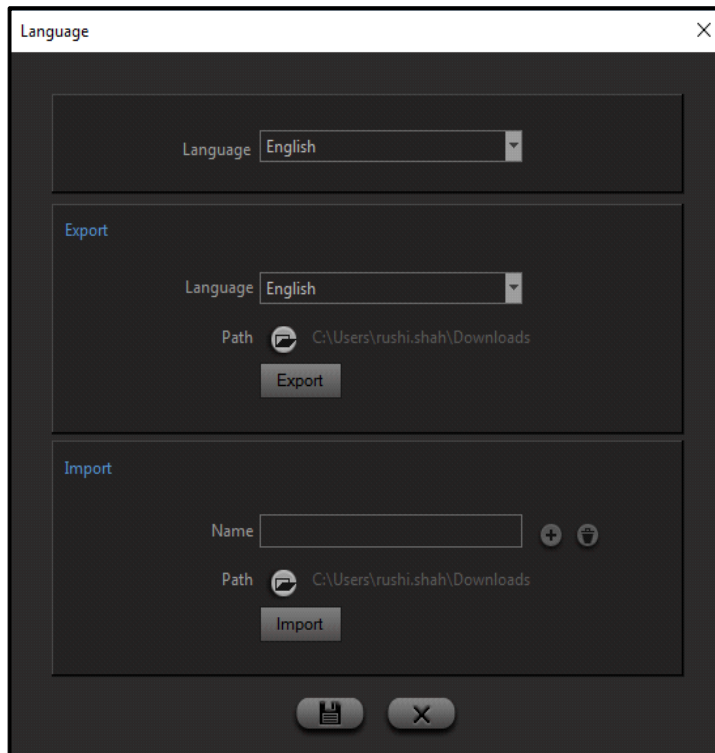

- **Language:** The total imported (saved) languages will be available at the drop-down list. Select the required one which is to be made as a default language.

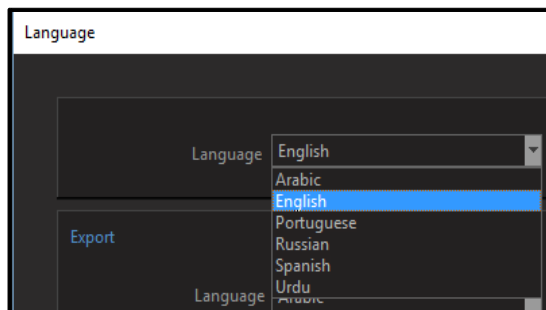

Except English Language (file), other language (file) must be imported first to make it available into the list for selection.

The updated language will be reflected in the Local Client after next login.

- **Export:**
 - **Language:** Select the required Language file from the drop-down list which is to be exported.

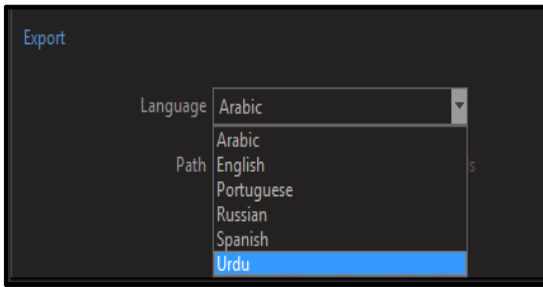

Except English Language (file), other language (file) must be imported first into the device client for export.

- **Path:** Choose the location at where the exported file will be saved by clicking on  icon.

Click on the **Export** button to export the file.

The exported file will be in .CSV format as shown below.

Configure.CSV File for Language

	A	B	C	D	E
1	English Label	Translated Label			
2	Error while connecting.				
3	Multi-login is not allowed.				
4	Maximum session limit reached				
5	You do not have permissions for this operation.				
6	Configuration mismatch.				
7	Maximum stream limit reached.				
8	PTZ interface not configured.				
9	Max buffer limit reached.				
10	No modem found.				
11	Cannot establish connection.				
12	Error in connection. Please try again later				
13	Incorrect file name.				
14	Camera disabled.				
15	Alarm output disabled.				
16	Manual PTZ tour not configured.				
17	Manual recording disabled.				
18	No disk found.				
19	No events found.				
20	Admin user cannot be blocked.				
21	Camera Address Already assigned.				
22	Firmware Upgrade failed.				
23	Request already in process.				
24	More events available.				
25	Audio Disabled.Check Stream Settings.				

There are two label columns as **English Label (column A)** and **Translated Label (column B)** in the file.

The 'column A' will always be for the English language which contains different English Labels in rows.

User must translate each English labels into the required language and enter it into the same row of the Translated Label column. The sample file which is translated for 'Portuguese language' is shown below.

A	B	C
1 English Label	Translated Label	
2 Error while connecting.	Erro durante a conexão. Error while connecting.	
3 Multi-login is not allowed.	Multi-login não é permitido. Multi-login is not allowed.	
4 Maximum session limit reached	limite de sessão máxima atingida Maximum session limit reached	
5 You do not have permissions for this operation.	Você não tem permissões para esta operação. You do not have permissions for this operation.	
6 Configuration mismatch.	incompatibilidade de configuração. Configuration mismatch.	
7 Maximum stream limit reached.	limite máximo de corrente atingido. Maximum stream limit reached.	
8 PTZ interface not configured.	interface de PTZ não configurado. PTZ interface not configured.	
9 Max buffer limit reached.	Max limite temporário atingido. Max buffer limit reached.	
10 No modem found.	Nenhum modem encontrado. No modem found.	
11 Cannot establish connection.	Não é possível estabelecer conexão. Cannot establish connection.	
12 Error in connection. Please try again later	Erro na conexão. Por favor, tente novamente mais tarde Error in connection. Please try again later	
13 Incorrect file name.	nome de arquivo incorreto. Incorrect file name.	
14 Camera disabled.	Camera desativado. Camera disabled.	
15 Alarm output disabled.	saída de alarme desativado. Alarm output disabled.	
16 Manual PTZ tour not configured.	Manual do passeio PTZ não configurado. Manual PTZ tour not configured.	
17 Manual recording disabled.	gravação manual desativado. Manual recording disabled.	
18 No disk found.	Nenhum disco encontrado. No disk found.	
19 No events found.	Nenhum evento encontrado. No events found.	
20 Admin user cannot be blocked.	usuário administrador não pode ser bloqueada. Admin user cannot be blocked.	
21 Camera Address Already assigned.	Camera endereço já atribuído. Camera Address Already assigned.	
22 Firmware Upgrade failed.	Atualização de firmware falhou. Firmware Upgrade failed.	
23 Request already in process.	já pedem no processo. Request already in process.	
24 More events available.	Mais eventos disponíveis. More events available.	
25 Audio Disabled.Check Stream Settings.	Áudio Desativado.Check Configurações de Fluxo. Audio Disabled.Check Stream Settings.	

Save the file and the same way you can make .csv file for other languages also.

Currently, SATATYA NVRX/NVRX P2 variants support the below languages that can be set as default.

- English
- French
- Italian
- Spanish
- German
- Russian
- Portuguese
- Thai
- Chinese
- Japanese
- Arabic
- Urdu
- Persian
- Russian

User needs to maintain a separate .CSV file for each languages.

- **Import:**

Once the Language file is configured with all translated labels, user needs to import it back to the Device Client.



Make sure the Language file is saved and closed while importing.

- **Name:** Enter the name of the Language file which is to be imported. At the **Language** section, the Language will be identified with the given name.

- **Path:** Select the required path by clicking on  icon from where the file is located.

Click on the **Import** button to import the file. The validation message; *“Language File Imported Successfully”* will display on successful import.

The same way you can import other language files by clicking on the **Add**  button. User can import maximum 5 language files.



The name of the Language must be unique from other imported languages.

You can see the imported files into the drop-down list as shown below. Click on the **Delete**  button to delete the selected file.

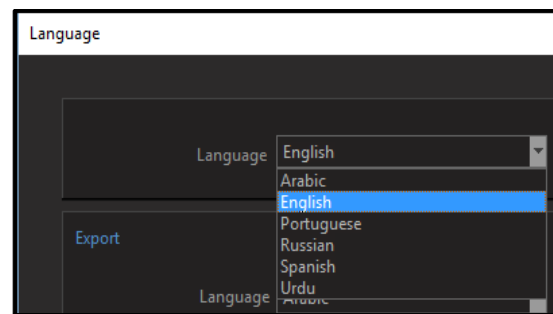
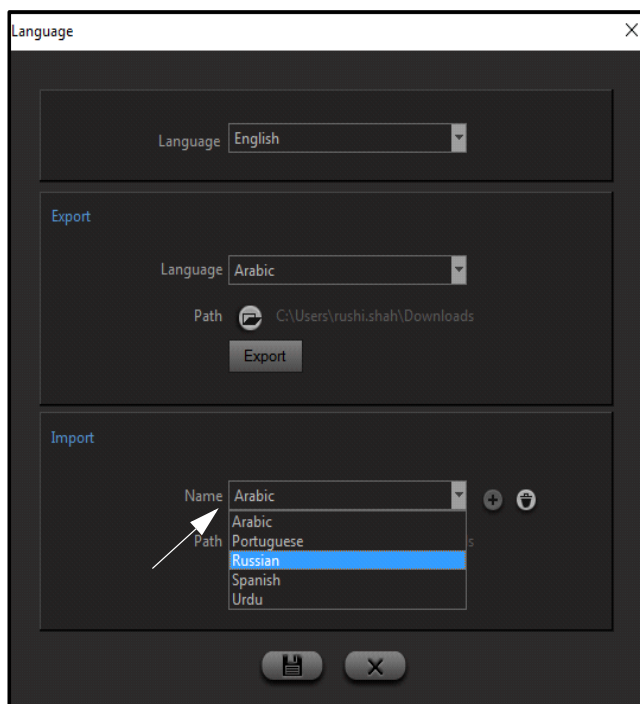

The total saved languages will be available in the Language drop-down list for the selection. Choose the required one and click on the **Save** button to save or **Cancel** to cancel the configuration.

System Control

This option enables the user to upgrade the firmware, shutdown, restart the system and default the parameters. By clicking on System, the following window appears.

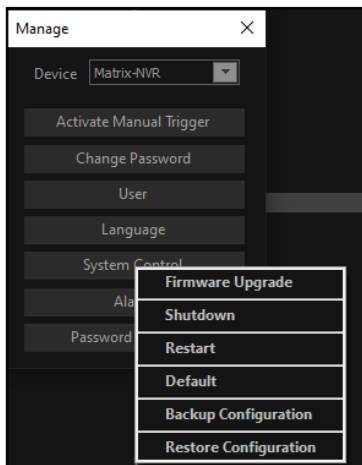

Firmware Upgrade:



*If you have added any **Axis** brand camera variant in your device and you wish to upgrade the device to the latest firmware version, that is 8.3.0, the Axis camera will be removed from the channel. You need to add the camera again via ONVIF or Camera Initiation (Brand-Generic). This is applicable to NVRX/NVRX P2 series only.*

Web Upgradation:

The Device Client application enables the user to upgrade the firmware of the SATATYA device. By clicking on Firmware Upgrade option, the following page appears. Click on the **Browse** button and navigate to the folder containing the firmware .zip file.

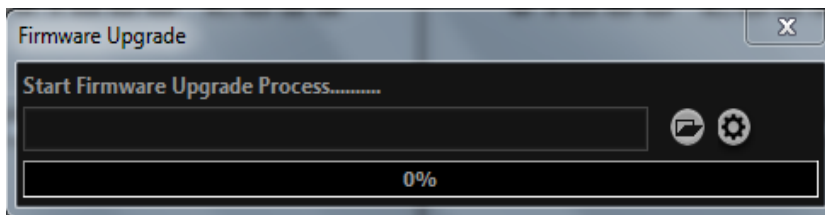

USB Upgradation:

Another way of upgrading the firmware of the SATATYA device is through USB. Using this way of firmware upgradation will change the configurations to default.



In NVRX/NVRX P2 series of devices, while upgrading firmware using USB 2.0 slot, USB 3.0 slot should not be in use.

The NVRX/ NVRX P2 devices can also be upgraded using Auto Firmware Upgrade. Refer to [“Firmware Management”](#) for details.

Shutdown/Restart:

This section enables the user to remotely restart or shutdown the device. Select the relevant option by clicking on the appropriate button. The system prompts for Username and Password as shown.

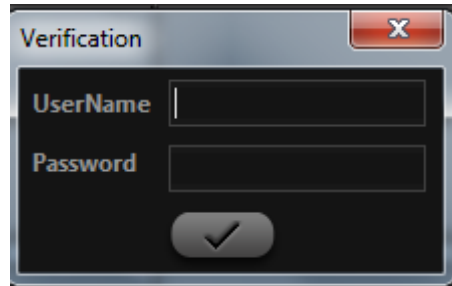
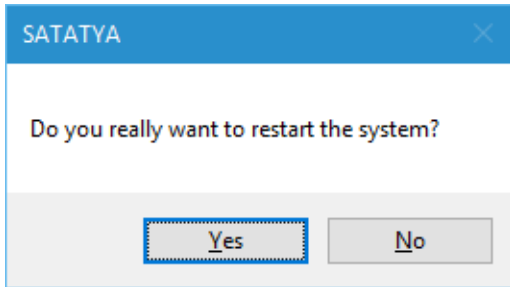

Default:

This option allows the user to default the parameters of the device. By clicking on Default, the following page appears:

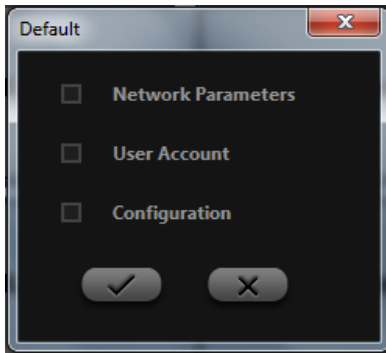

The system enables the user to default the following parameters:

- Network Parameters
- User Account
- Configuration

Enter the correct Username and Password to default the selected parameters.

Backup Configuration:

This option allows the user to take backup of the configuration.

Restore Configuration:

This option allows the user to restore the configuration.

Alarm Output



Alarm Output is not applicable to NVRXS P2 Series.

This option enables the user to manually **activate** or **deactivate** the relay output as and when required. By clicking on Alarm Output, the following window appears. The availability of number of alarm output ports will depend on the device variant.

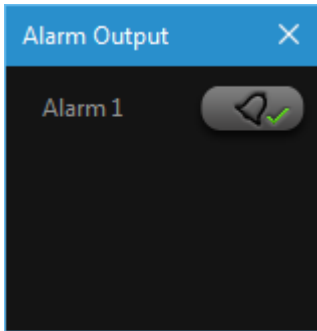

The button toggles between **Activate** and **Stop** based on the current status of the output as shown.

Password Recovery

This option enables the user to configure the Email ID and Security Questions which are used to recover the password. The Email ID/Security Questions can be configured during the first login. But if not done then can be configured now. The Email ID/Security Questions if configured at the time of first login can also be modified now.

On selecting this option, the following page appears.

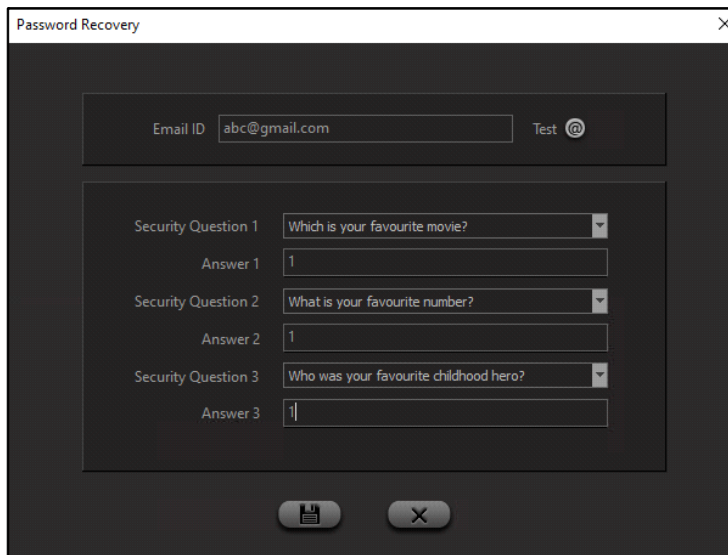

Enter the Email ID through which the password recovery will be done.

- Click **Test**  to send a test email to the entered Email ID.

Select the Security Questions from the drop-down list. Specify the answers for each of them.

Click **Save** to save the settings.



*The **Password Recovery** tab is applicable for NVRX/NVRX P2 series only. Password Recovery is not supported in cascaded devices. For example: Device installed is NVR0801X, now we add a new device NVR64S, then this tab will be visible but will be un-editable.*

Modifications done in the Password Recovery tab will be logged as events under Event Logs.

Device Configuration

Click on **Device Configuration** section from the Left pane of device client. The Configuration Settings window appears as shown below.

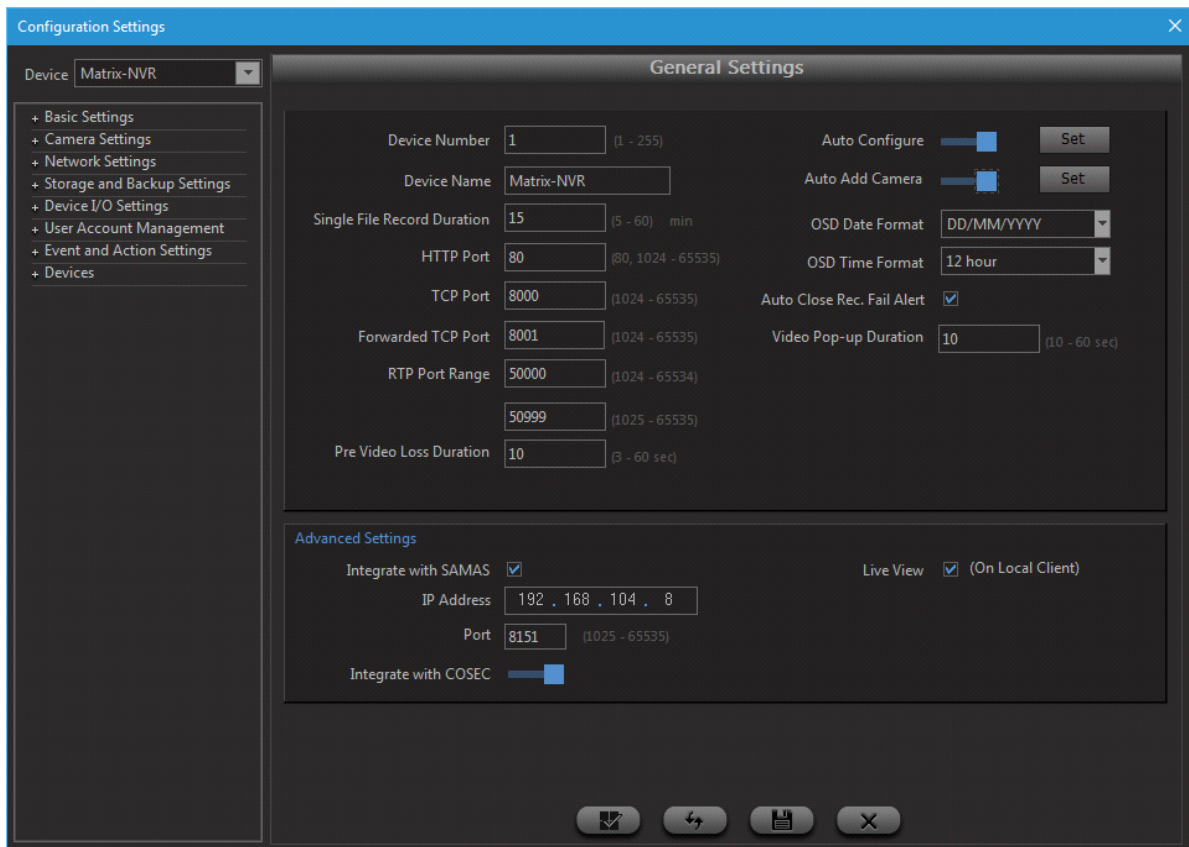

For detailed description on Device Configuration See [“Device Configuration” on page 223](#).

Local Settings

Click on **Local Settings** from the Left pane of device client. This option enables the user to define the local storage locations as well as the record duration of the recorded files to be stored. On selecting this option the following page appears.

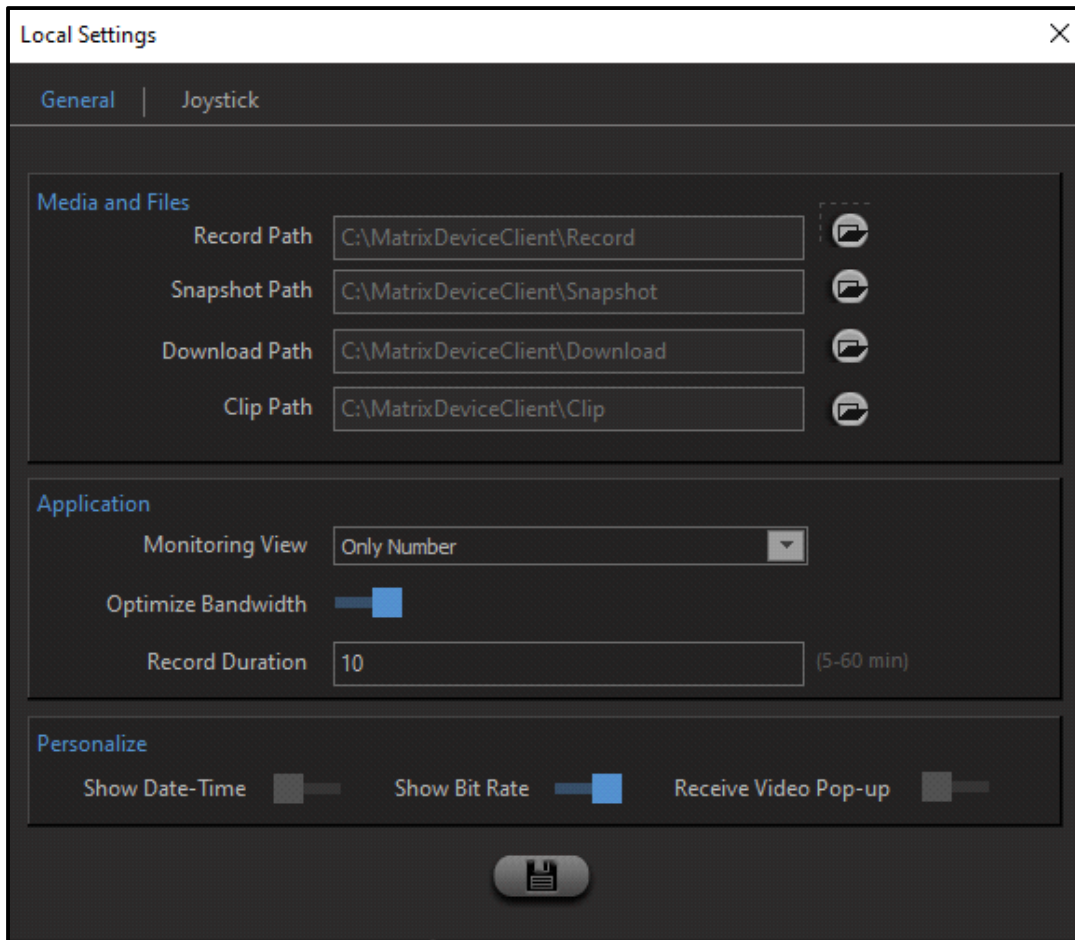

General

Click the General tab and configure the following parameters:

Media and Files

The storage path can be set for the following files:

- **Record Path:** The user can define the path to an existing folder on the local computer where the locally recorded files shall be saved. Click on the Browse button and navigate to the folder where these files will be stored. By default, the files will be stored at '**C:\MatrixWebClient\Record**'.
- **Snapshot Path:** The user can define the path to the local folder where the captured images using the snapshot option will be saved.
- **Download Path:** The Device Client has the facility to download recorded files from the SATATYA device to the local machine. Specify the folder path where these files will be stored.

- **Clip Path:** The user can define the path to the local folder where the clips will be saved.



When the non-administrative user who does not have the access rights of C: drive tries to access the storage path of Media and Files located at C: drive, the access permission will be denied.

Those users must change the storage path of Media and Files to another drive (with user rights) to access the media and files.

Application

- **Monitoring View:** You can select the monitoring view option as **Only Number** or **Logo with Number** for display on the monitoring window.
- **Optimize Bandwidth:** Drag the slider to the desired level to allow optimization of bandwidth. This means, when you select a layout in such a way that it contains more than 1 window i.e. above 1X1 layout, then sub stream will be applied in all the windows if this check box is enabled.
- **Record Duration:** In case of the locally video recorded files, the user can specify the duration of the recording per stored file in this field.

Personalize

- **Show Date & Time:** Enable the slider to display date and time monitoring window.
- **Show Bit Rate:** Enable the slider to show bit rate on the display of monitoring window.
- **Receive Video Pop-up:** Enable the slider to receive video pop-up window when a configured event occurs. If enabled the pop-up will appear. If this option is disabled on a specific machine, then that particular machine will not receive the video pop-up when an event occurs. But if the device client is open in some other machine then that machine will get the video pop-up.
Example: Suppose there are 3 machines PC1, PC2, PC3 and the parameter “Receive Video Pop-up” is disabled in PC1. Now when any configured event occurs, PC1 will not get the video pop-up but PC2 and PC3 will get the video pop-up on their screens.

You can also enable Video Pop-up option in the Local Client from the toolbar.

Click on **Save** once done.

Joystick

Device Client supports all standard USB joysticks and gaming controllers which are compliant with Microsoft Windows operating system to operate PTZ cameras. Joystick is connected to the system via USB port.



- *This functionality is supported in the variants — NVRX/NVRX P2 Series and NVR64P/S.*
- *Make sure the Camera supports PTZ functions.*

The following actions are supported by the Joystick:

- Zoom In
- Zoom Out
- Focus Far
- Focus Near
- Iris Open
- Iris Close
- Set Auto Focus
- Set Auto IRIS

- Open/Close Instant Playback
- Close Video pop-up
- Enter/Exit Full Screen
- Go to Preset Position
- Tale Snapshot
- Audio On/Off
- Next Page
- Previous Page
- Clear Window
- Start/Stop Device Manual Recording
- Start/Stop Page Sequencing

Click the **Joystick** tab to configure the following parameters.

Click **Refresh** button to detect the joystick connected to the system. The detected Joystick will appear in the drop-down list as shown in the screen below.

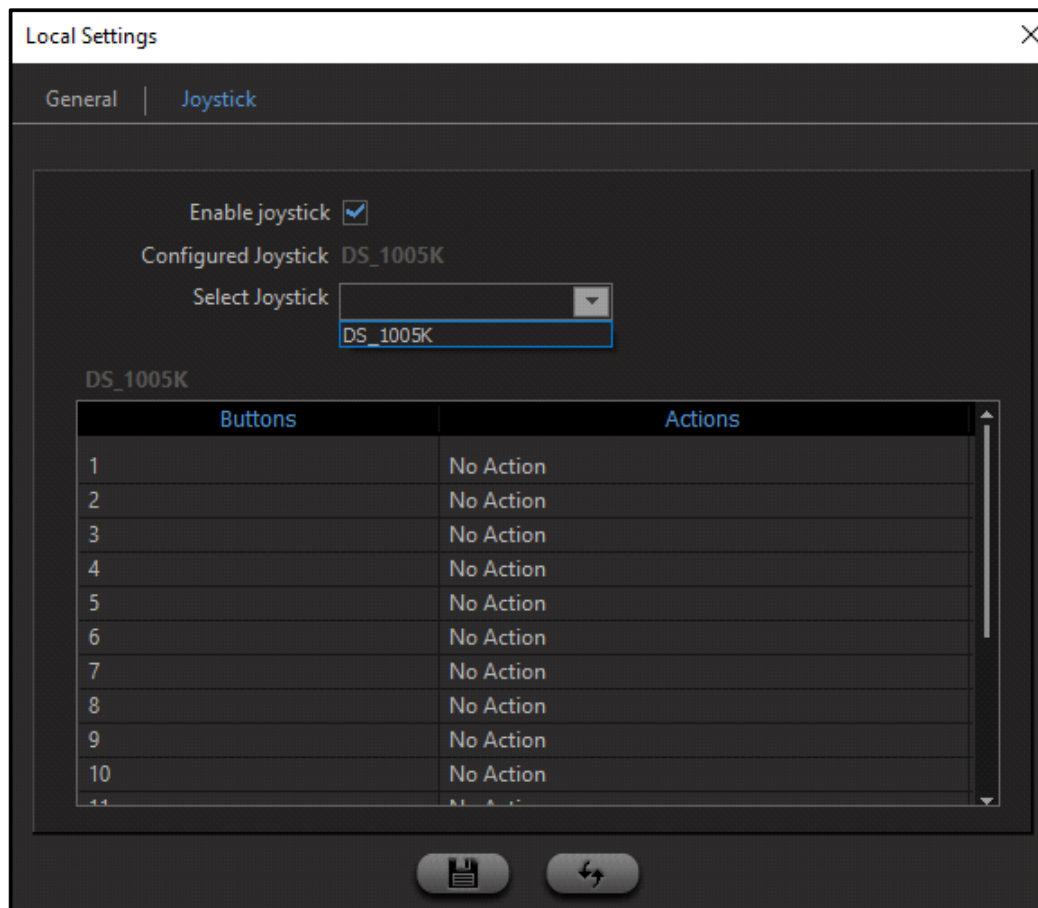

Select the **Enable Joystick** check box.

In **Select Joystick**, select the desired Joystick from the drop-down list. All the Buttons and Actions supported by the NVR/NVRX variants will be listed. You can assign the required actions to the buttons of the Joystick.

In **Configured Joystick** the name of the selected Joystick is displayed. When the Joystick is connected the

Connected  indication will appear and when it is disconnected the Disconnected  indication will appear.

To assign an Action to the required Button,

- Double click on **No Action**, corresponding to the desired **Button** number.

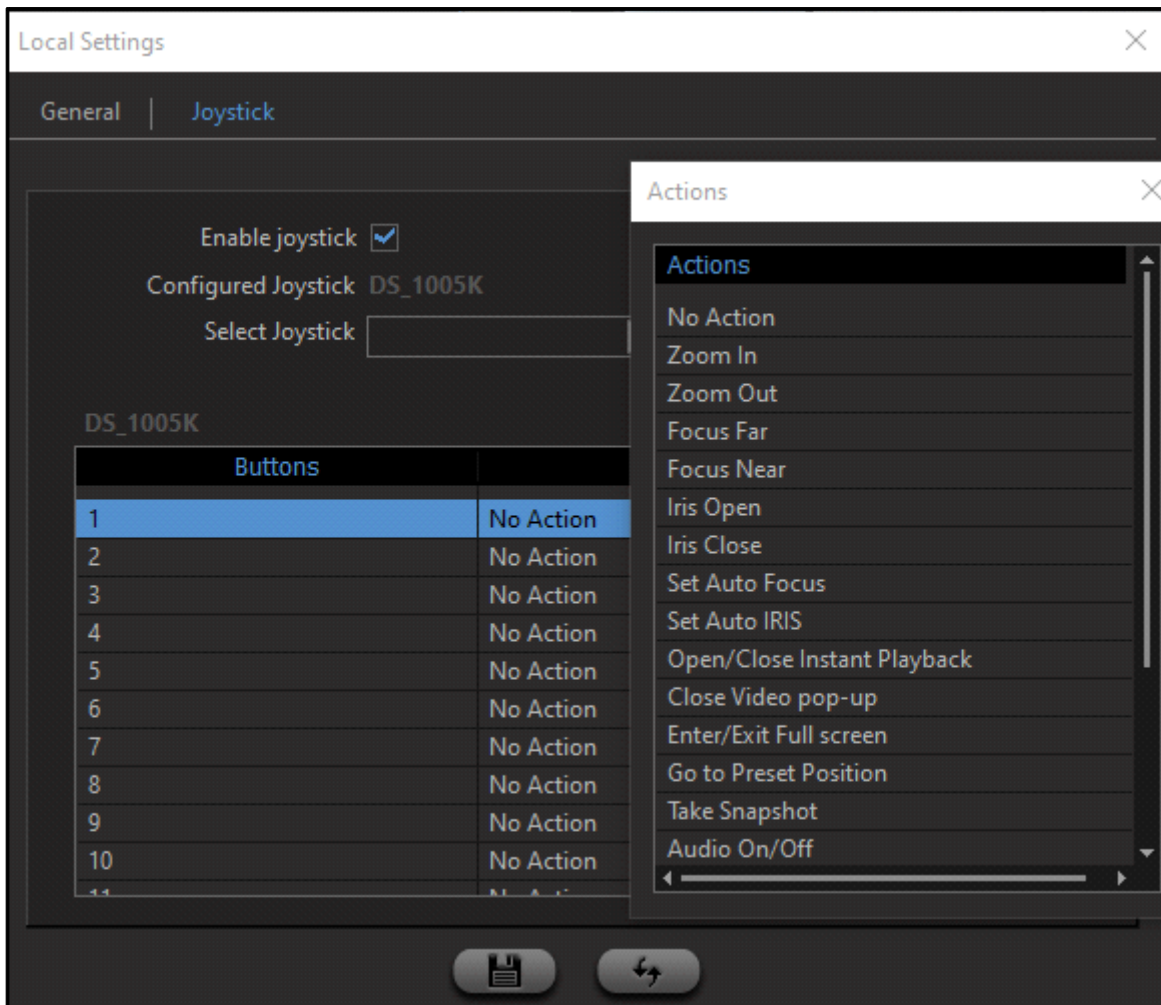

- The **Actions** pop up appears.
- Double-click on the action you wish to assign to this button.

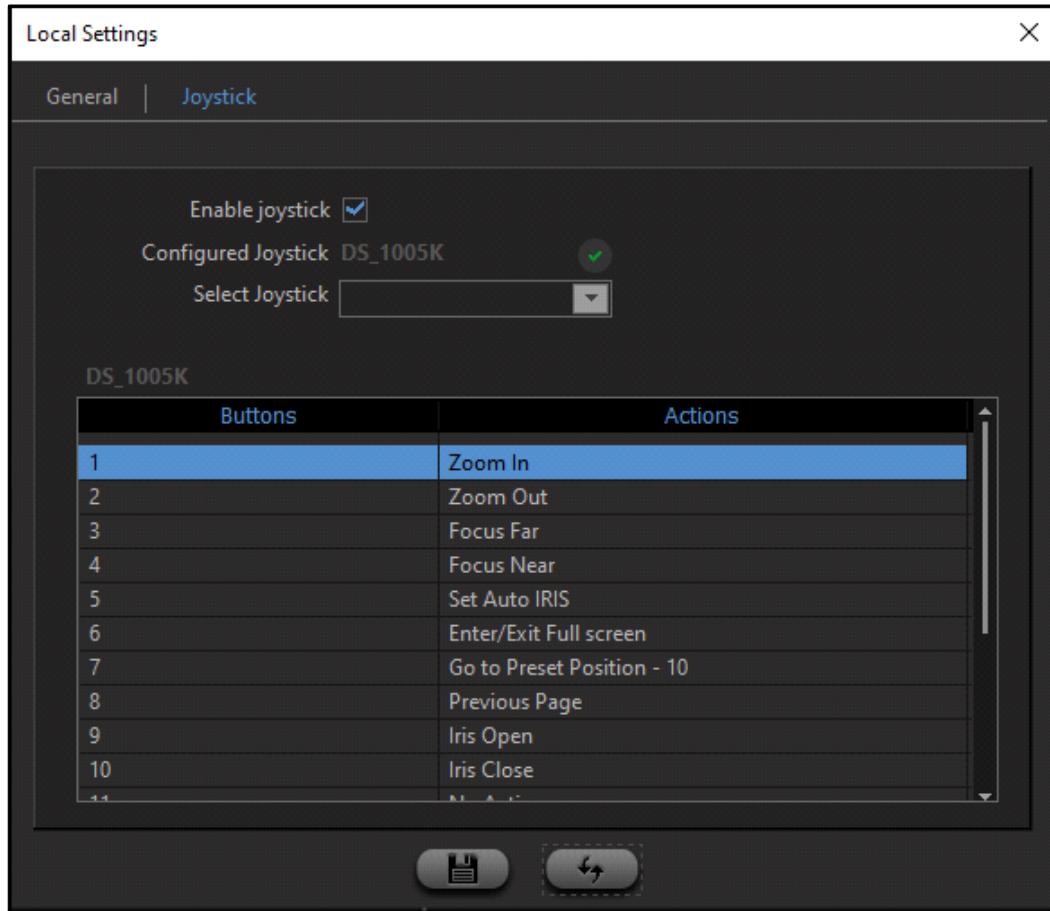

- The Action appears against the corresponding Button number.
- Similarly, you can assign Actions to other Button numbers.
- Click **Save**.

Once you have configured the desired Buttons and their Actions, the PTZ functions as well as other functions mentioned above can be controlled using the Joystick.

Quick Setup

This option enables you to set up the basic parameters of NVRX/NVRX P2 like Time and Language, Network, DHCP Server, Storage, Camera Configuration and Search Camera quickly.

Click **Quick Setup**  from the left pane. The **Quick Setup** pop-up appears.

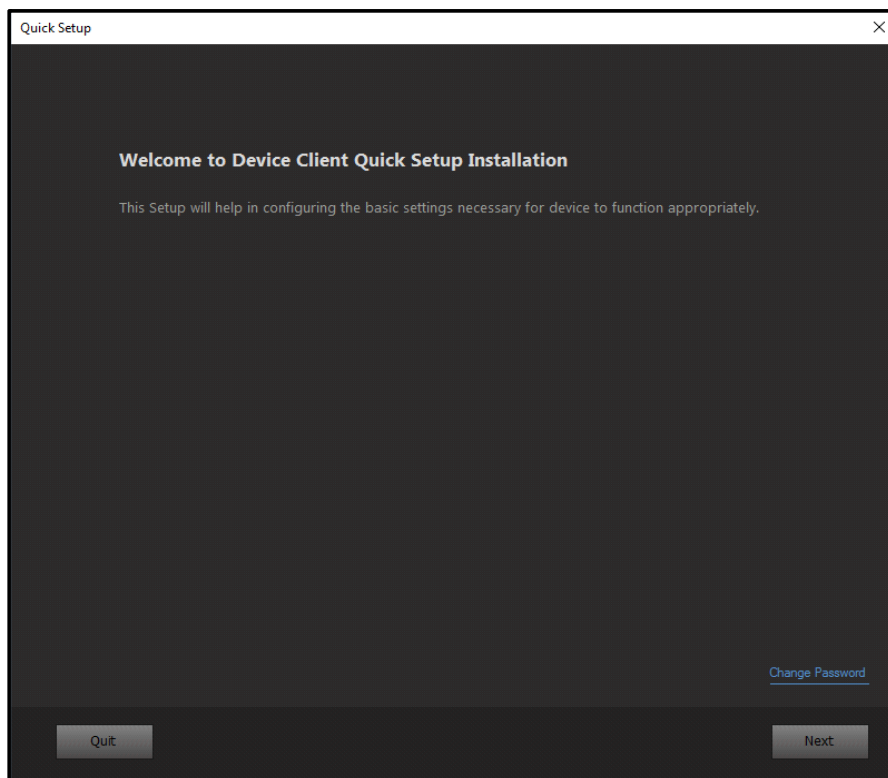

The configurations of Quick Setup Wizard for Device Client are similar to the Local Client. For details, refer to [“Quick Setup Wizard”](#).

Click **Quit** to cancel the Quick Setup process.



The Quick Setup Wizard is applicable for NVRX/ NVRX P2 variants of SATATYA Devices.

Logout

Click on **Logout** from the left pane of device client to log out of the application.

Camera Monitoring Window

Monitoring Window

The home page of the Device Client displays a 2 x 2 default viewing window. The right pane consists of the list of channels on the device as explained earlier. Click on the **Connect All** option by right clicking on the device to view all the channels in the viewing area.

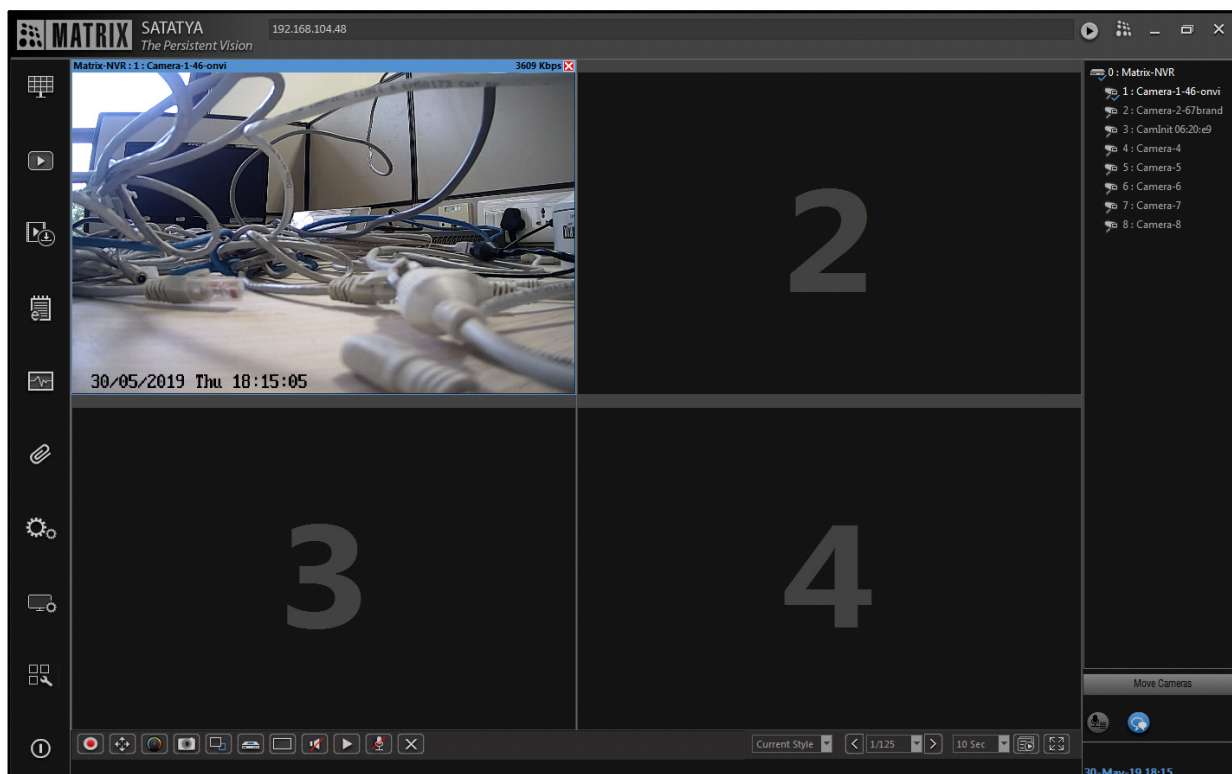

User can perform the “Digital zoom” on the monitoring display as shown below.

Digital zoom

Digital zoom feature provide users to perform Zoom IN/OUT just by scrolling the mouse Forward/Backward respectively pointed on ‘monitoring window’ in any layout format.

To know more about Layouts, [See “Layout” on page 186.](#)

To execute Digital zoom in Device client, It can be done directly by scrolling the mouse pointed on monitoring window whereas, in Local client user needs to click on **Zoom**  button from the toolbar.

- User can drag the zoomed frame to any part of the screen and perform zoom IN/OUT.
- User can perform the zoom till 1/6th part of the screen. (For example: If the current resolution is 1280x720 then, after maximum zoom, 213x120 resolution picture can be drawn on the screen)
- After right clicking & pressing the ‘Exit’ button on monitoring window, User can exit from the digital zoom functionality in Local client.

Controls

The following icons appear from left to right at the bottom of the viewing area when a channel is selected by clicking in the monitoring window.



Camera Settings Menu button shown above is available only for Analog PTZ Camera.



Start Recording:

This option enables to start the local manual recording of the selected channel. The recorded files of pre-defined duration are stored at the path as set from the **“Local Settings”** of the Device Client. Click on the icon again to stop the recording. The record files are stored at the specified path in **.stm** format. Now, the user cannot view this file and so a device player is needed which converts the **.stm** file into avi format.



Camera Settings Menu: This option enables to open the analog PTZ camera settings menu by entering the preset position as shown below.

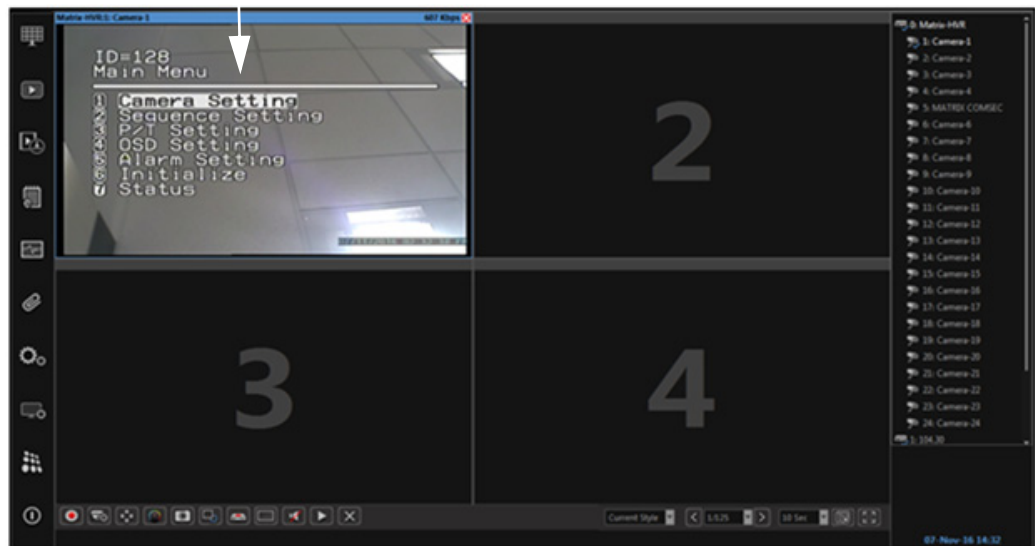
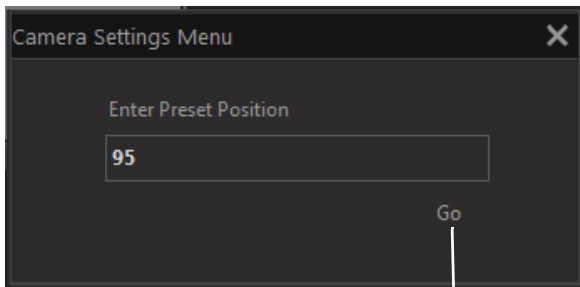

Once the menu is opened, you can navigate through the menu using the Tilt Up, Tilt Down and Iris plus and minus buttons from the PTZ Control pop-up window.



PTZ: This option enables to access the PTZ controls for the selected channel. It also enables to navigate through the camera settings menu of the analog PTZ camera. User can also start the manual PTZ Tour for the selected channel. This tour is configured from the **“Preset Tour”** option. PTZ functions can also be controlled using the Joystick. For details, refer **“Joystick”**.

Using this option, user can also control zoom and focus of following variants of Matrix IP cameras added via Brand Model or ONVIF in SATATYA Device.

- SATATYA CIDR20VL12CW-P
- SATATYA CIBR20VL12CW-P
- SATATYA CIDR30VL12CW-P
- SATATYA CIBR30VL12CW-P
- SATATYA PZCR20ML33CWP
- SATATYA PZCR20ML25CWP



Color: This option enables the user to change the brightness, contrast, saturation and hue of the selected channel. User can also adjust the volume setting for the Audio from this option.



Snapshot: This option enables the user to click an image from the selected channel at any particular instant of time and also print can be taken. The Video Codec while taking the Snapshot in Device Client is displayed below the image.

The captured images are stored at the path as set from the **“Local Settings”** of the Device Client.

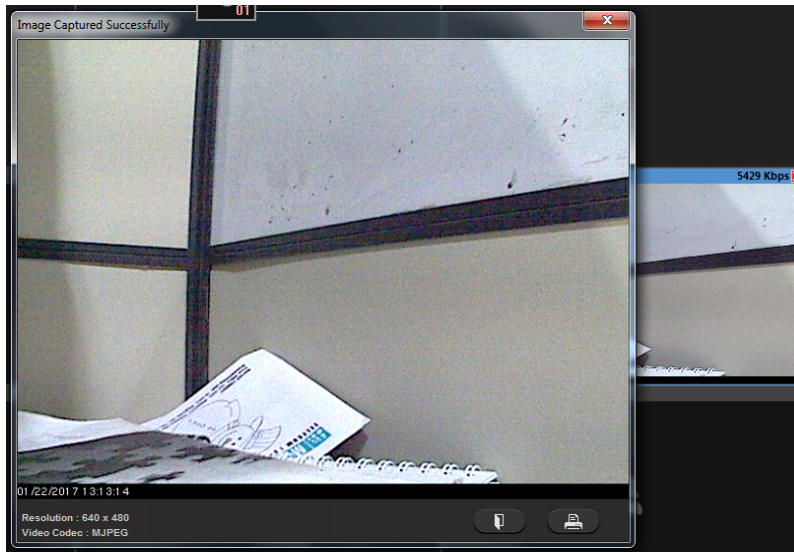

Sub Stream: This option enables the user to view the live display or record in substream mode. The button toggles between main stream and sub stream modes. Note: This feature may not be supported by all the cameras.



Start Device Recording: This option enables the user to start manual recording on the SATATYA device of the video from highlighted channel/window and the recording is stored in the hard disk of SATATYA device.



Fit to Display: This option enables the user to change the display of the monitoring window to 4:3 or 16:9 and normal aspect ratio.



Enable Audio: This option enables the user to enable or disable the audio output of the selected channel. Click on the icon again to toggle between the two states.



Instant Playback: This option enables the user to view the instant playback of the previous 5 minute recording on same monitoring window.



Speak Now: This option enables the user to send the audio from device client to the camera output. See [“Speak to Camera \(Speak Now\)” on page 182.](#)



For NVRXS P2 series, Speak Now will not be accessible from the Local Client. However you can use the same from Device Client



Close: This option enables the user to stop the live streaming from the selected channel by clicking on the cross button.

Move Cameras

To move the configured camera(s) from one device to another device; click on **“Move Cameras”** option at the right bottom of Device Client window as shown below. The Move Cameras window will appear.

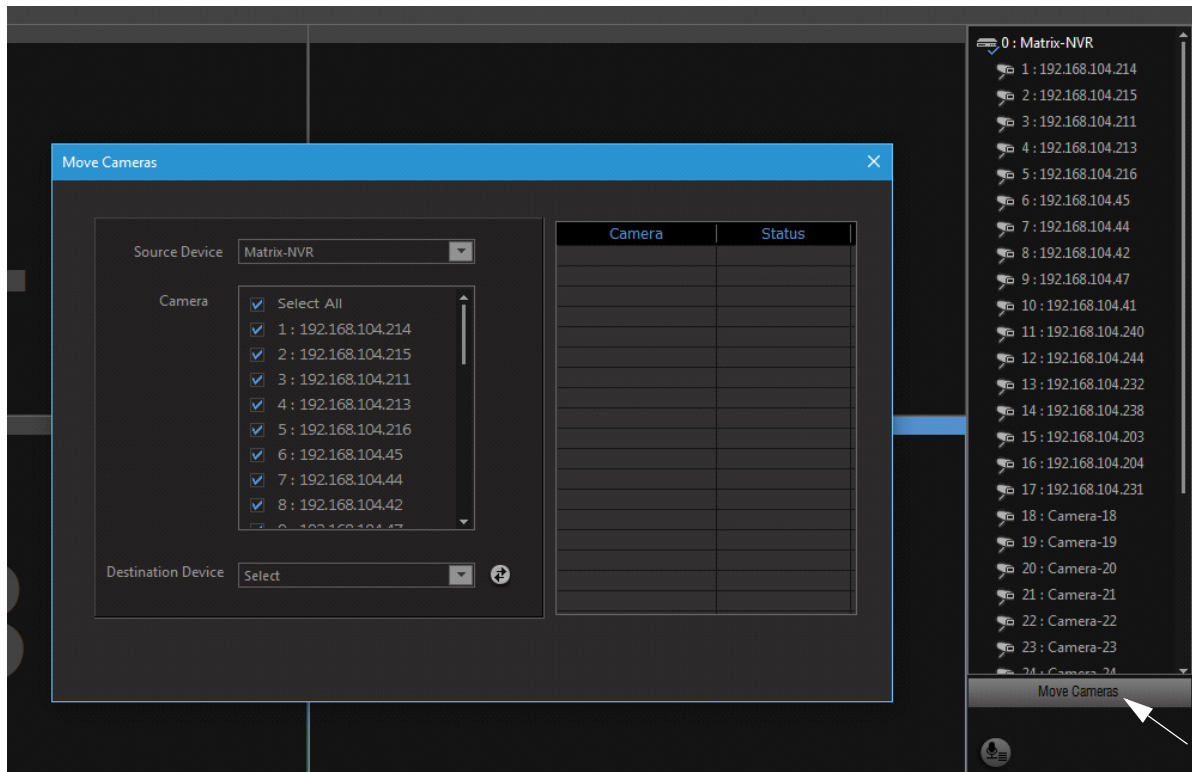

Source Device: Select the device from drop-down list whose camera is to be moved. Eg: HVR 24P

Camera: Select the checkbox for the camera to be moved. Eg: Camera 2: UPNP

Destination Device: Select the device from the drop-down list where the camera is to be moved. Eg: Matrix-NVR

Click **Move Camera** button.

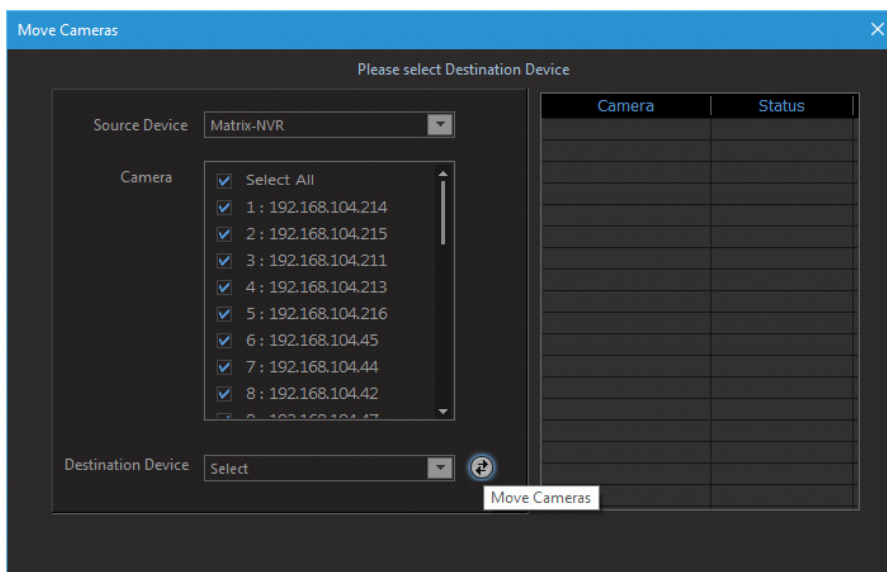

Device Configuration

The Device Client enables the user to configure the SATATYA device (NVR/HVR) from a remote workstation. The Configuration option on the Device Client application enables the user to configure the following settings.



The Configuration Settings are not to be accessed by the user type viewer.

- Basic Settings
- Camera Settings
- Network Settings
- Storage and Backup Settings
- Device I/O Settings
- User Account Management
- Event and Action Settings
- Devices

The **“Basic Settings”** option enables the user to configure the following functionalities:

- General
- Date & Time
- Daylight Saving Time

The **“Camera Settings”** option enables the user to configure the following functionalities:

- Camera Search
- Camera
- Stream Settings
- Image Settings
- Recording
- Adaptive Recording
- Schedule Snapshot
- Image Upload
- PTZ Interface
- Preset Position
- Preset Tour
- Audio Settings
- Alarm Output

The **“Network Settings”** option enables the user to configure the following functionalities:

- LAN1
- LAN2
- DHCP Server Settings
- Broadband
- Static Routing
- IP Address Filtering
- Matrix DNS Client
- DDNS Client
- E-mail Client
- FTP Client
- TCP Client
- Media File Access

- SMS
- Monitor Client
- P2P

The **“Storage and Backup Settings”** option enables the user to configure the following functionalities:

- HDD
- Network Drive
- Storage
- Backup
- USB

The **“Device I/O Settings”** option enables the user to configure the following functionalities:

- Sensor Input
- Alarm Output

The **“User Account Management”** option enables the administrator to define, edit or delete users as from the system.

- User Account
- Password Policy

The **“Event and Action Settings”** option enables the user to configure the following functionalities:

- Camera
- Device Sensor
- System

The **“Devices”** option enables the user to add and configure upto 20 network devices

The **“Maintenance”** option enables the user to configure the following functionalities:

- Firmware Management

Refer the relevant part of this manual by clicking on the respective links for more details on configuring the above functionalities.

The common buttons on the configuration pages are mentioned below:



Default: Click on Default button to default the settings.



Refresh: Click on Refresh button to restore the previous settings.



Save: Click on Save button to save the changes.



Cancel: Click on Cancel button to remove the changes.

The Basic Settings option enables the user to configure the basic parameters of the SATATYA device. The following functionalities can be configured under this option.

“General”

“Date and Time”

“Daylight Saving Time”



You can enter the value for “time” using keyboard as well.

General

Click on the **Configuration** option from the left pane of Device Client. The **Configuration Settings** page appears. Select the **General** option from **Basic Settings**.

The General Settings page for **HVR1624 P/S** and **HVR0824P/S** is shown as below.

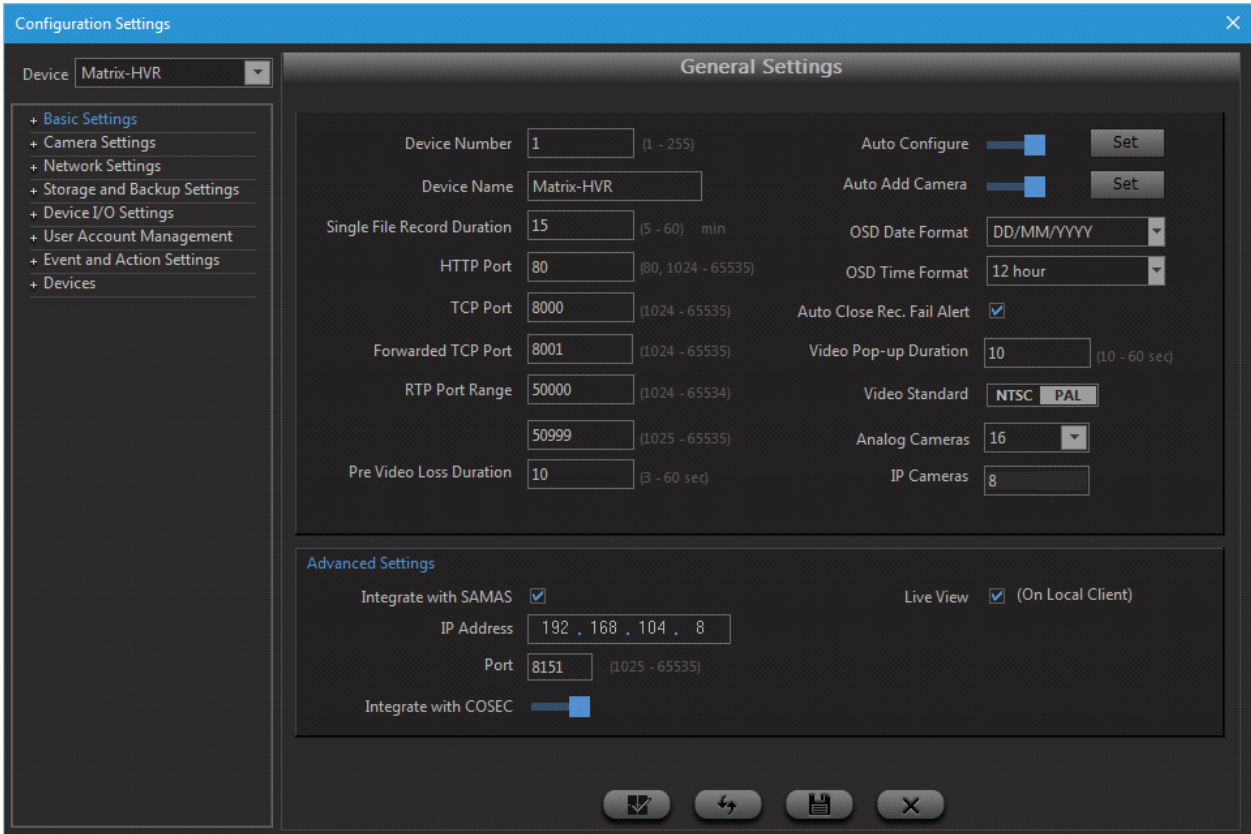

Device Number: Specify a Device number between 1 to 255 which is an identification of the device.

Device Name: Specify a unique name for the device.

The General Settings of **HVR 0408 P/S** is shown as below:

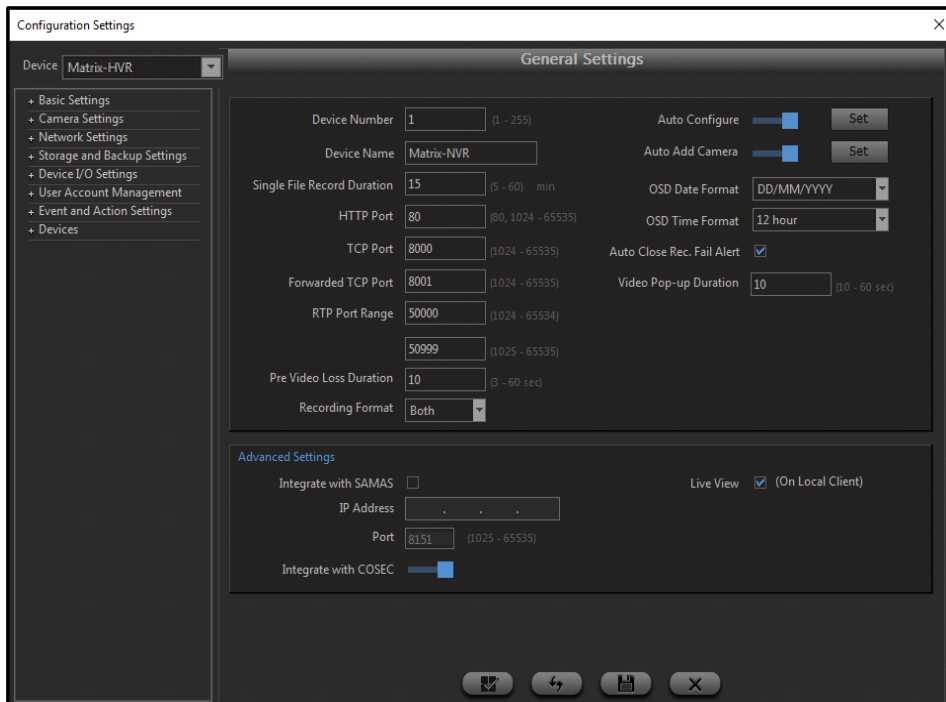

The General Settings of **NVR8S** is shown as below:

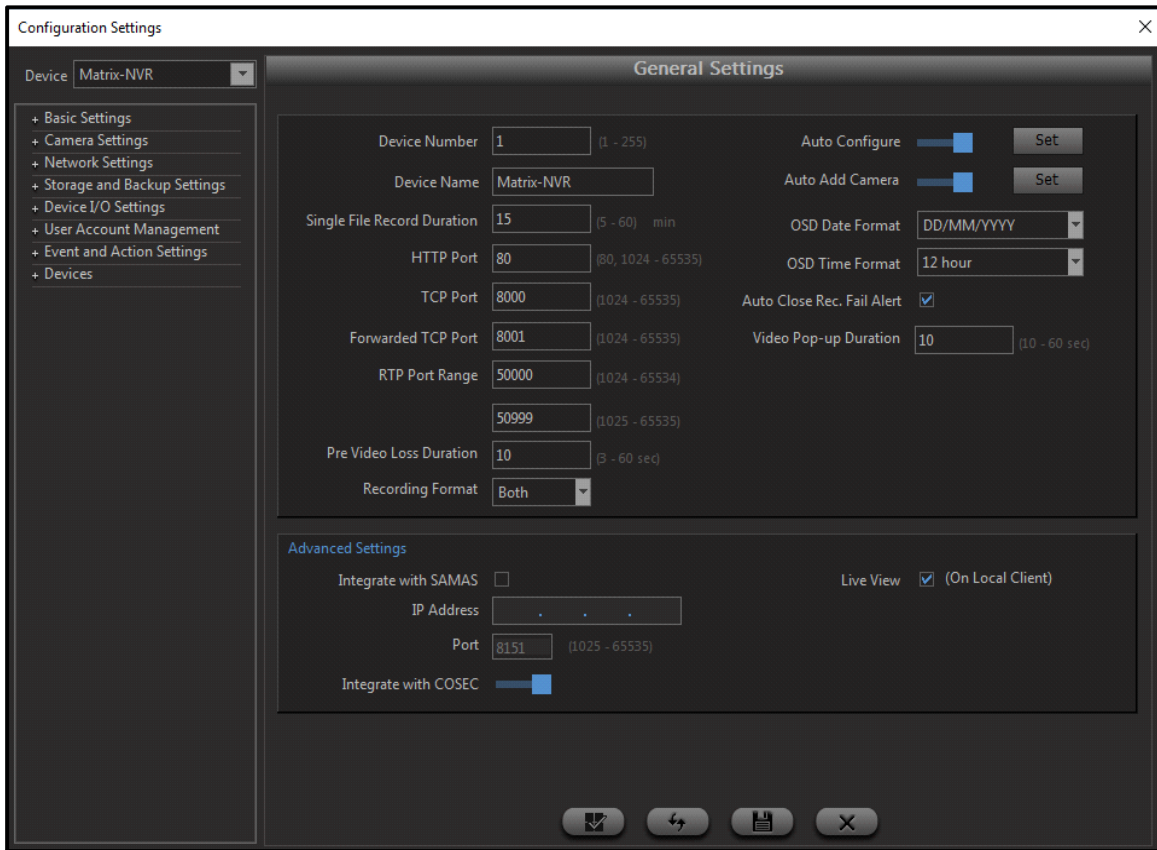

The General Settings of **NVR64 P/S, NVR24P** is shown as below:

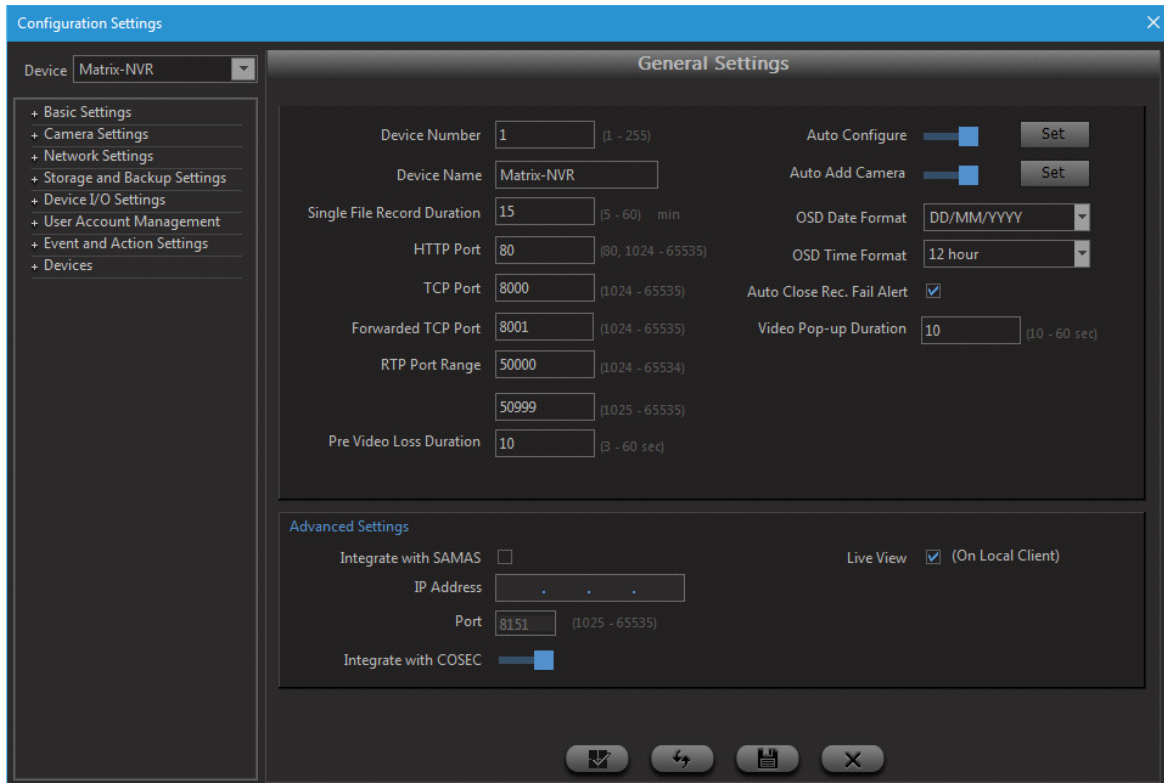

The General Settings of **NVR0801X** is shown as below:

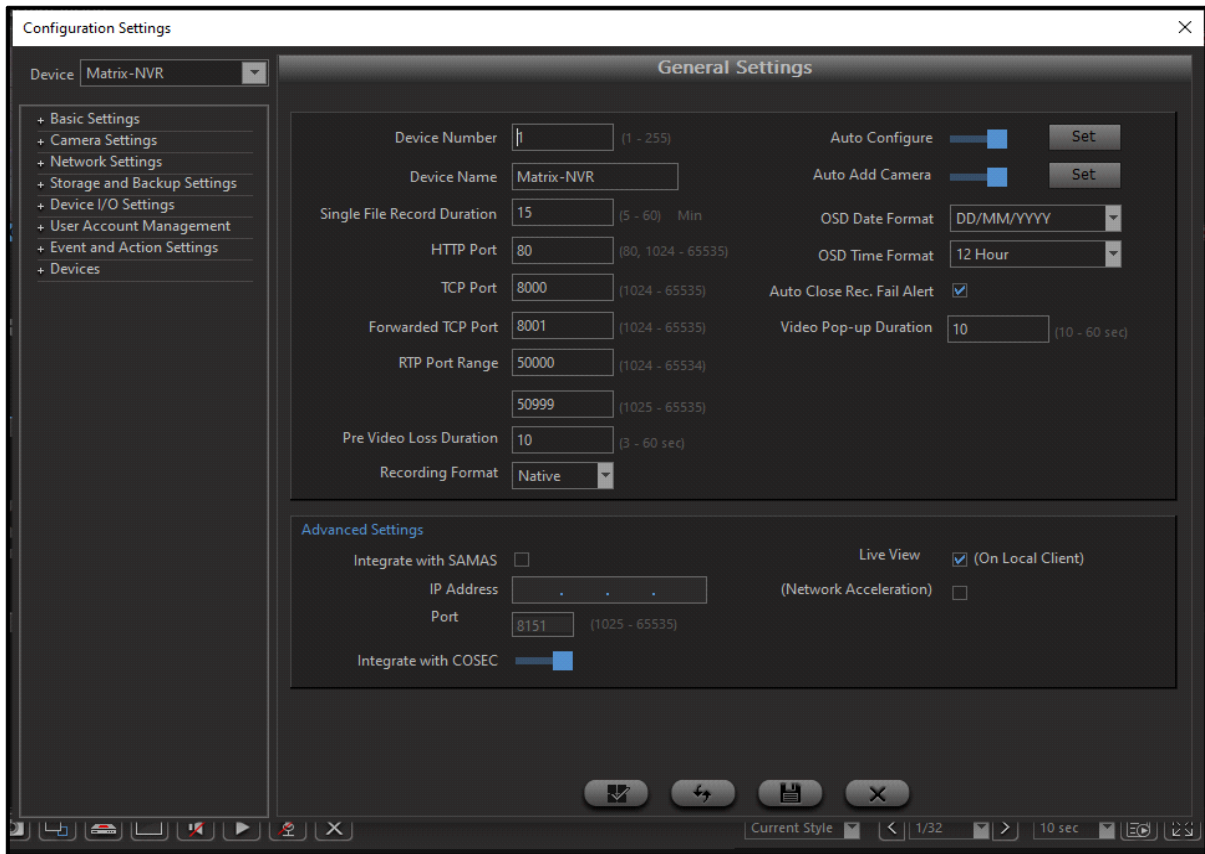

The General Settings of **NVR0801X P2** is shown as below:

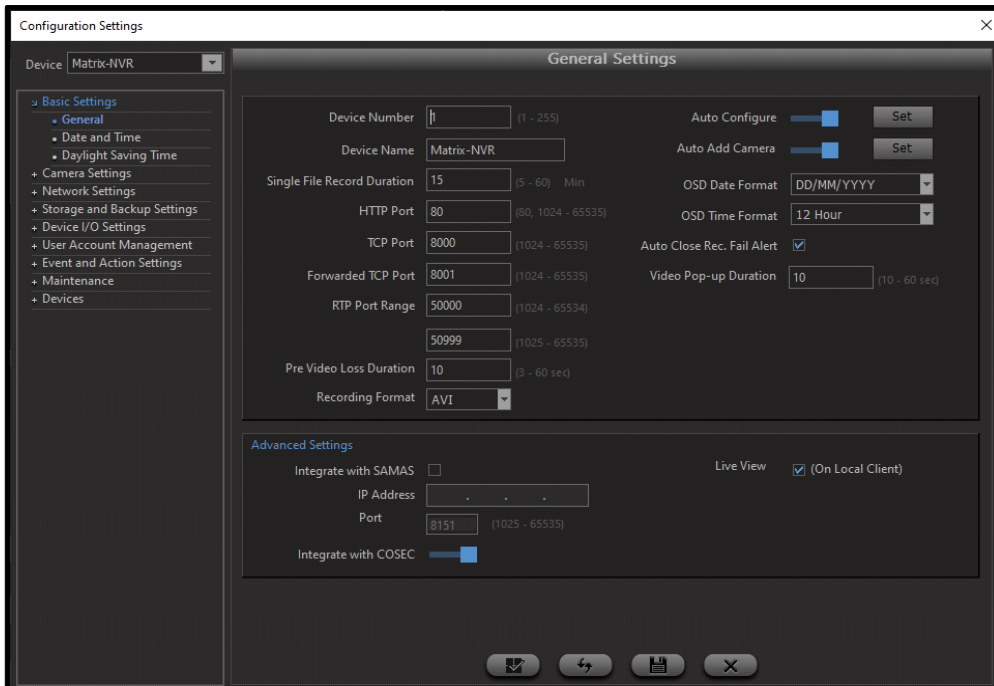

Single File Record Duration: This parameter enables the user to control the size of the video recording files on the SATATYA device. Set the time in minutes as per the site requirements ranging between 5 to 60 minutes.

HTTP Port - Specify the HTTP port which will be used by the SATATYA device. The default setting is 80. Alternatively, any port in the range 1024-65535 may be used, but check first with your network administrator before changing the default setting. The HTTP port is used for remote internet browser access. This port is used by the Device Client application to send the http request to the device for connectivity.

TCP Port: Specify the TCP port which will be used by the SATATYA device. The default setting is 8000. Alternatively, any port in the range 1024-65535 may be used, but check first with your network administrator before changing the default setting. The TCP Port is used for remote client software access. The Device Client interact with the device on this port.

Forwarded TCP Port: Specify the Forwarded TCP port where the user wants to forward the request, arriving from the other network. The default setting is 8001. Alternatively, any port in the range 1024-65535 may be used, but check first with your network administrator before changing the default setting. Here, the Forwarded TCP Port is used to connect MY DEVICE.

Example:

Consider that the user wants to connect to MY DEVICE.

Suppose user has done the following configuration in **Device Client -> Device Configuration -> Basic Settings** for My Device.

TCP Port = 8000

Forwarded TCP Port = 8001.

SCENARIO 1: When MY DEVICE and the PC where Device Client is installed, are configured at the same network.

In this Scenario, when the user tries to login using credentials at the login page, MY DEVICE connects successfully by using the normal **TCP Port = 8000**.

SCENARIO 2: When MY DEVICE and the PC where Device Client is installed, are configured at two different networks.

In this Scenario, when the user tries to login using credentials, MY DEVICE connects successfully by using the **Forwarded TCP Port=8001** and not by the normal TCP Port=8000 as, request has arrived from the other network.

SCENARIO 3: When the user tries to connect to MY DEVICE for the first time.

In this scenario, the user enters username and password and clicks on the login button. The MY DEVICE tries to connect via **TCP Port** appearing at the login page. If the port is valid then, the device will be connected successfully otherwise it will be connected via Forwarded TCP Port.

SCENARIO 4: When the checkbox “Stay Signed In” is enabled at the Login Page.

In this scenario, the user will be able to connect to MY DEVICE directly with the help of port with which MY DEVICE was connected previously.



*To connect the MY Device through the **Local Client**, only SCENARIO 1 and SCENARIO 2 explained above will be applicable.*

RTP Port: Specify the RTP listening port range of the SATATYA device on which the device will communicate with the IP cameras. The default setting is 50000 for the Start Port and 50999 for the End Port. Alternatively, any port in the range 1024-65535 may be used, but check first with your network administrator before changing the default setting. This is required in the event of the camera being located on the Internet and the device being located behind a router.

Pre Video Loss Duration: This feature is applicable to both Local client and Device client. You can configure the time duration of Video Loss after which the Video Loss is to be displayed.

Enter the time duration after which the Video Loss is to be shown (i.e. declaration of Video Loss). In this configured duration, the last frame will be displayed. When this configured duration is completed, then video loss will be declared.

Recording Format: Select the format from the drop-down list in which you need to do the recording. The option are: **Native**, **AVI** and **Both**.



Recording format selection is available only in HVR 0408 P/S, NVR8S, NVR0801X and NVR0801X P2.

It is recommended not to change the recording format frequently. If the recording format is changed from AVI to any, then the recording files which are available in current hour recording folder will get deleted after reboot.

Quick Backup, Synchronous & Asynchronous playback and Instant Playback will not work for the recorded files in .avi format.

Auto Configure

Local Device:

The **Auto configure** parameter is enabled by default. This gives a pop-up displaying a message whether to auto configure all the searched cameras or not on system boot.

If **Yes** button is clicked, all the searched cameras in the configured network will gets automatically configured. You can specify user-name and password with which cameras are to be added.

The user-name and password can also be set from the configuration settings of auto configure.

If **No** is clicked, the cameras will not be added.

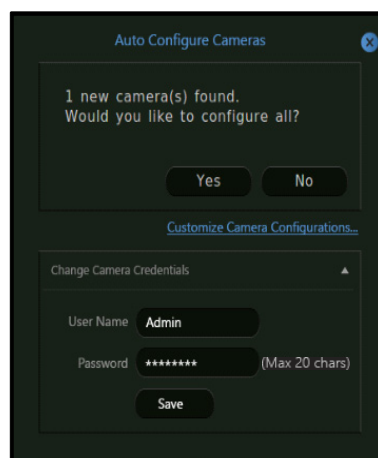

When there is mismatch in the entered credentials and the credentials with which the camera is configured, then the camera will not be added.

- **Example:** On system boot up, 3 cameras are auto discovered (2 are matrix cameras and 1 is Dahua camera). The user is trying to auto configure all 3 cameras with User-name as Admin and Password as Admin which are the default credentials of matrix camera. So, the two matrix camera will get added successfully and the Dahua camera will not get added as the user-name and password of Dahua camera is root; admin.



Suppose If a user (Sheetal) is created and password is not set in the Matrix camera. And if you add this camera in SATATYA device with the user-name and password as Sheetal; then on Auto configure request; password will get set on the camera and the live stream will start on the local display.

Device Client:

Enable to activate auto configuration of the camera and click **Set** button to configure the Auto configuration settings.

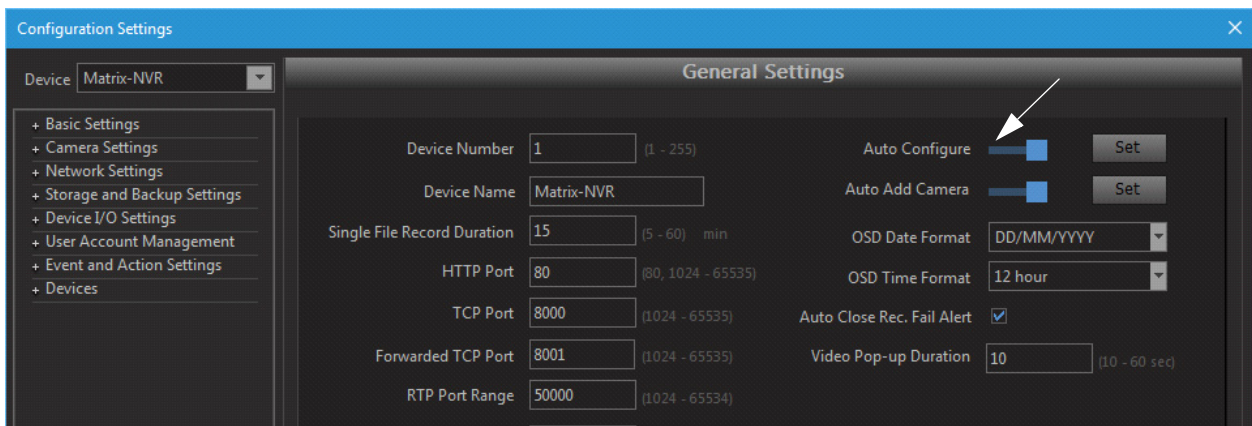

- **Auto Configure Settings pop-up:**
Clicking on **Set** button will open a **Auto Configure Settings** pop-up window as shown below.

- **Retain same IP Address:** If the box is checked then searched camera(s) will be added with same searched IP Address. If the box is not checked then user can define the range to auto configure. All the cameras will be assigned IP address from the defined range. By default, this checkbox is enabled.
- **Auto Configure Range:** This is the range in which identified cameras will be auto configured.
 - **Start/End IP Range:** Define a range in which you want to assign IP address to the camera by specifying start and end IP address.
- **User Name/Password:** Enter the username and password of your choice with which the camera is to be added in the device.
- **Retain Camera Default Profile:** If the box is checked then live stream for camera will auto start with camera default profile. If not checked then user can set the desired parameters of Main Stream and Sub Stream for live stream.

Auto Add Camera



1. Auto Add camera feature is supported in all the SATATYA Devices.
2. The features is configurable using Device Client and Local Client both.

Auto add camera feature allows the user to add the cameras in the Device via camera initiation. In this, camera initiates communication with the device client and gets added to the device automatically.



To achieve camera initiation, you need to prior add the Device Client Server details (IP address and TCP Port) at the Matrix IP camera web page

- Click **Set** button to configure the parameters for Camera Initiation feature as shown below.

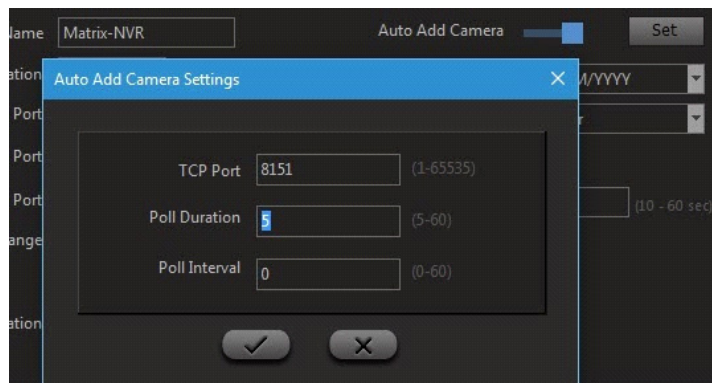
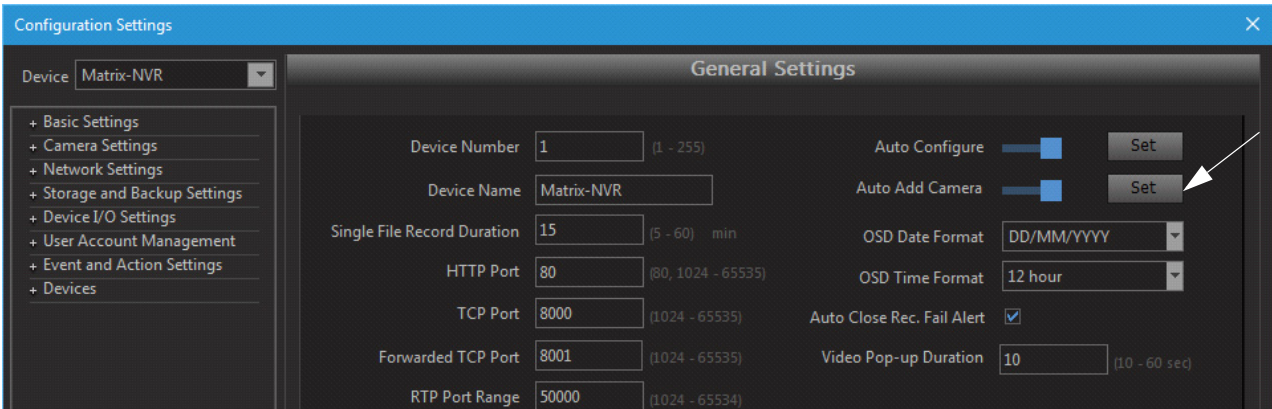

- Specify the **TCP Port** to establish the communication between Device client and IP camera.



Specify the same TCP Port as specified at the Matrix IP camera web-page.

- Specify the **Poll duration** in seconds till which the IP camera should wait for response from the device for communication.
- Specify the **Poll Interval** in seconds after which IP camera should send the next poll.
- **Save** the setting after configuring the parameters.

Enable the **Auto Add Camera** option, to add the Matrix IP camera to the device automatically.

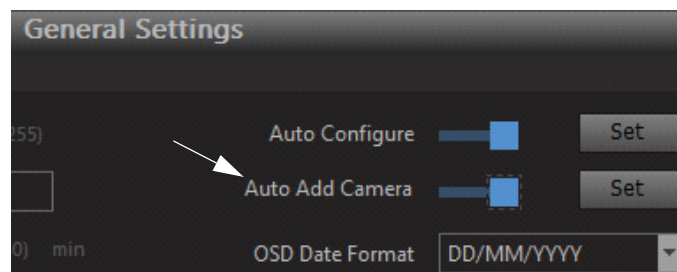

If this option is not enabled, then the camera will appear in pending state for activation in *Camera Settings* > *Camera Search* page. This shown below. For more information, See [“Auto Add Camera” on page 249.](#)

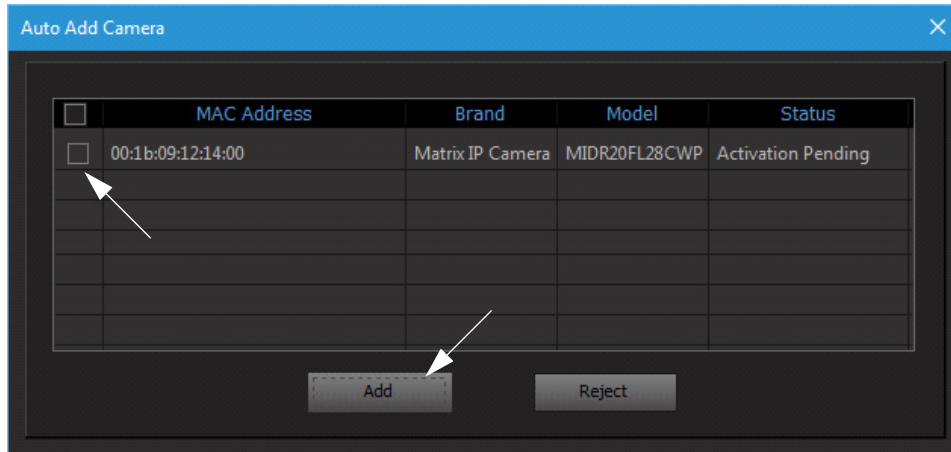

To add the camera, select the checkbox beside the camera and click on **Add** button as shown above.

OSD Date Format: Select the date format to be set for on screen display.

OSD Time Format: Select the time format to be set for on screen display.

Auto Close Rec. Fail Alert: Select the checkbox to automatically close the recording failure event pop-up after 3 seconds for that particular device, and display the pop-up next time when the event is generated again for recording failure. If disabled, the alert will be displayed on recording failure event and not automatically closed. The alert generated is as shown below.

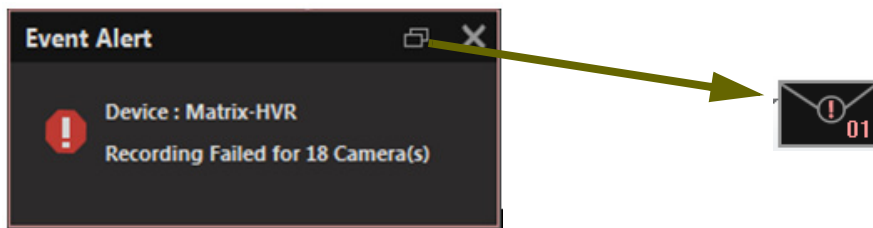

One can also restore the size of the alert into a message box and vice versa as per requirement.

Video Pop-up Duration: Specify the duration in seconds after which the video pop-up window should get closed automatically. The default value is 10 seconds.

In **Device Client** you can also close the video pop-up window manually by clicking on **Close** button as shown in the below screen.



In **Local Client** you can also close the video pop-up window manually by clicking the **Exit** button as shown in the screen below.



Video Standard: Select the Video Standard from the options of **PAL** or **NTSC**.

Analog Cameras: Select the analog cameras from the drop-down options of 4,8,12 and 16.

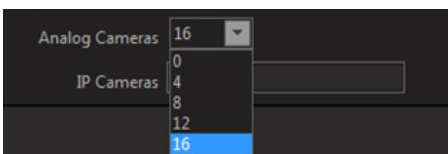

IP Cameras: Based on the number of analog cameras selected, the number of IP cameras is updated. The total number of cameras being 24.

Advanced Settings

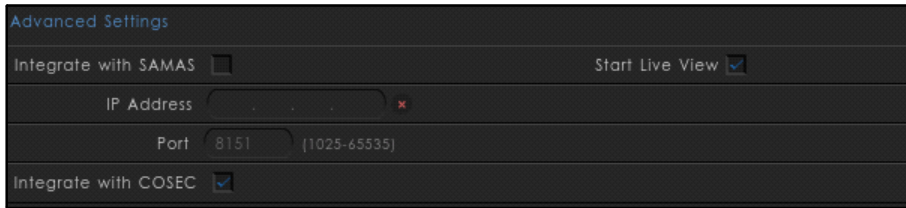

Integrate with SAMAS: Check the box to integrate the SATATYA device with SAMAS.

- **IP Address:** Specify the IP address of the Recording Server to which the SATATYA Device will be added. If Auto addition is enabled in SAMAS then device will be added automatically.

If **Integrate with SAMAS** is disabled, the  indication will appear.

If the integration with SAMAS is successful,  indication will appear and if the integration is

unsuccessful,  indication will appear.

The  icon will appear for the following states— Connection Failed, Connection in progress, Request Pending at SAMAS.



*The status icons for **Integrate with SAMAS** are applicable for NVRX/NVRX P2 series only.*

- **Port:** Specify the “Auto Add Device Port” as specified in SAMAS Recording Server Manager.

Integrate with COSEC: Enable to integrate the SATATYA device with COSEC.

Start Live View: Enable or Disable the **Start Live View** check box to start or stop the live view of the cameras assigned in the live view layout page of the **Local Client** respectively. By default, this checkbox is disabled.

This checkbox is available both in Local Client as well as in Device Client.

Now, suppose the **Start Live View** check box is disabled in General settings, now when the system will boot up, the Auto-configure pop up will appear to the user in the Local Client.

Case1: If user clicks No in Auto-configure pop up:

- If the user clicks on **No** button in Auto-configure pop up, then the pop up asking “**Would You like to start live view of cameras**” will appear to the user. Click **Yes** to start the live view.

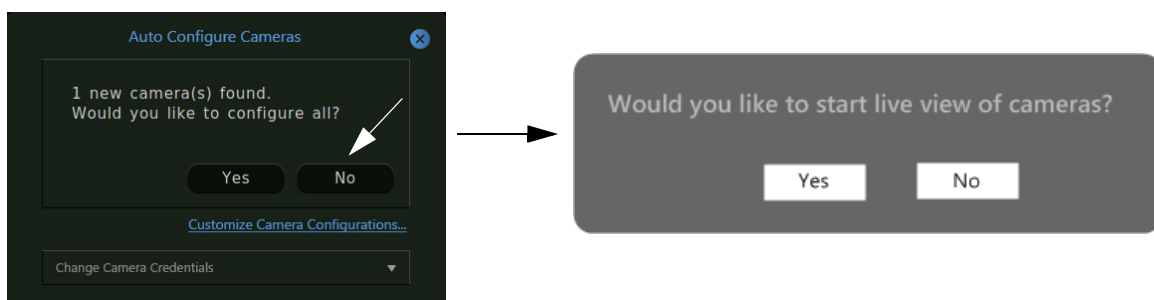

Case2: If user clicks Yes or Close the Auto-configure pop up:

- If the user clicks on **Yes** or **Close** the Auto-configure pop up, then in 10 seconds this pop up will appear again and after 5 minutes the pop up of **“Would You like to start live view of cameras”** for live view will appear and the auto configure pop shall get closed automatically.

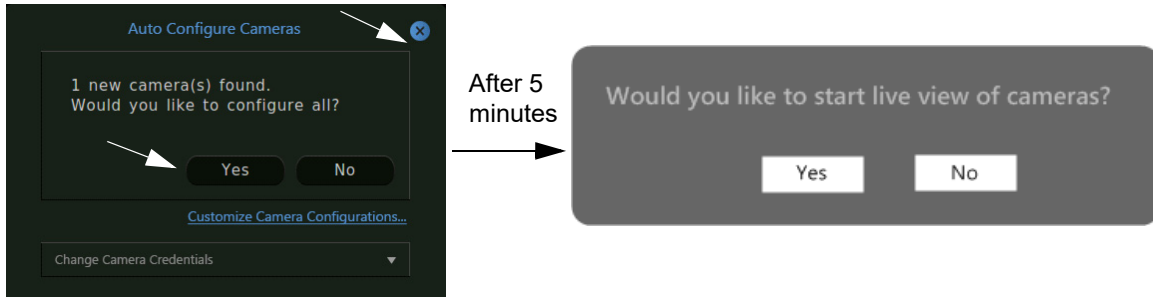

The pop up of **“Would You like to start live view of cameras”** will appear to the user just after the other pop ups (HDD clean up, HDMI resolution, if configured) appear.
Local user would need the login credentials to change the configuration of live view.

HDMI resolution pop-up will not appear in NVRX and NVRX P2 series of devices.

Click on **Save** once done.



When you connect one or more devices to a network through an IP sharing device, each device must have a unique TCP port number for remote access to each unit from outside the LAN (Local Area Network).

In NVRX variants, **Network Acceleration** option is provided for both Local and Device Client as shown below.



Network Acceleration option is not applicable to NVRX P2 variants.



You can enable this option to make the streaming process smooth when there are multiple number of IP Devices/ Cameras (approx more than 35) are connected with your NVRX. The option is disabled by default.



It is suggested for a user to observe the current streaming of cameras on the live view first and enable the Network Acceleration option as per the necessity.

If you enable or disable Network acceleration then pop up of “Device may misbehave if configured network is inappropriate at the current session. Continue with reboot “will appear on screen as shown below.

Once the 'Network Acceleration' is enabled or disabled, then a pop up will appear as shown below.

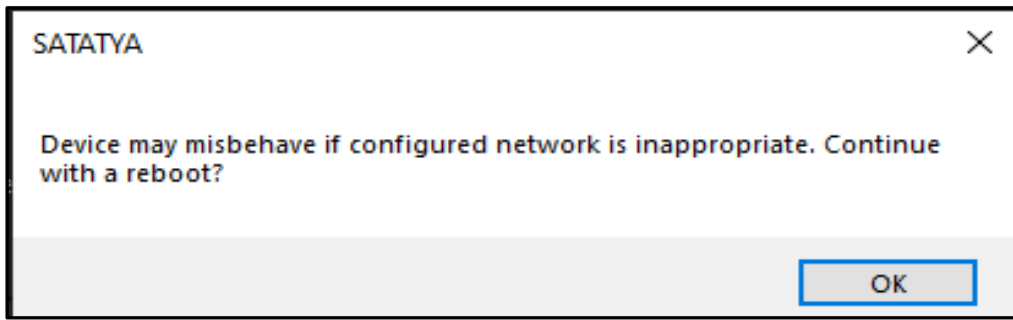

Make sure the configured network is stable while making the Network Acceleration enabled or disable.

Date and Time

Click on the **Device Configuration** option from the left pane of device client. The **Configuration Settings** page appears. Select the **Date and Time** option from **Basic Settings**. The **Date and Time** Settings page appears as shown below.

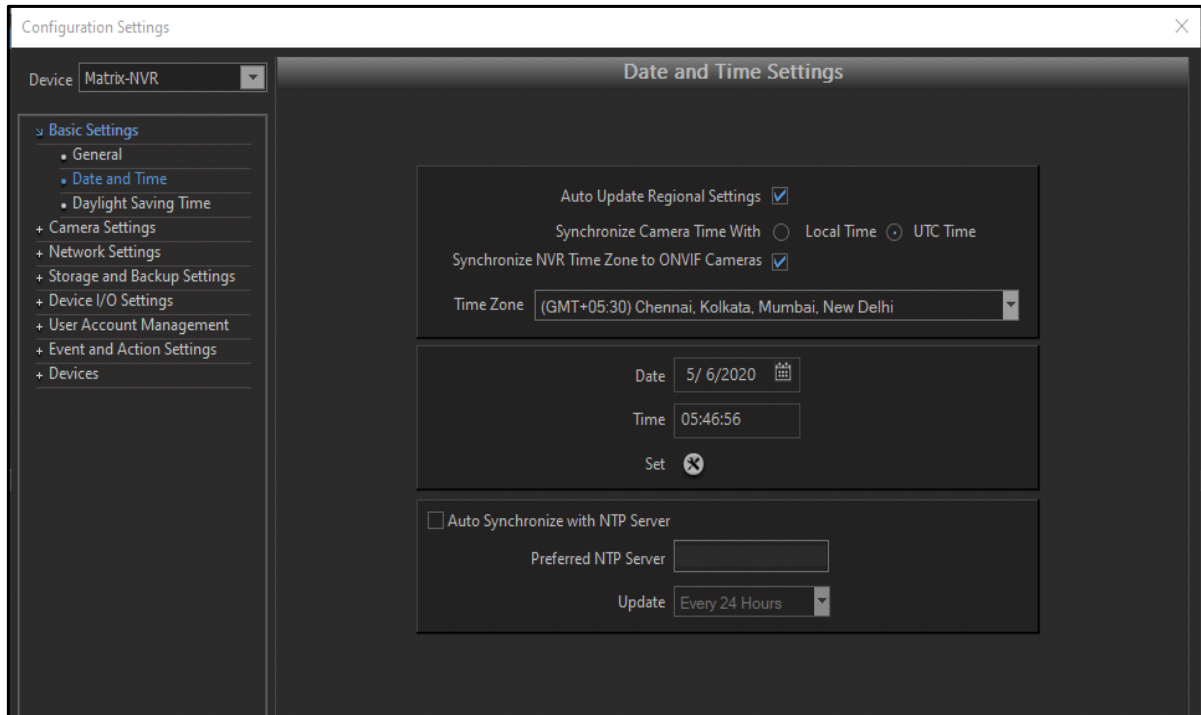

Auto Update Regional Settings: Enable to automatically update the regional settings such as Video Standard (NTSC or PAL) and Date Format according to the selected Time Zone.

In case of **Local Client**, if the parameter “Auto Update Regional Settings” is enabled and if the device is connected to the public IP or the dongle is connected to the device, then the time zone and its regional settings also gets automatically updated as per the region. If disabled then only the time zone will get updated on detection of the Internet dongle or public IP network.

When dongle or public network is detected on the system then an information pop-up of time Zone detected appears on the screen on the right hand side as shown in the screen below.

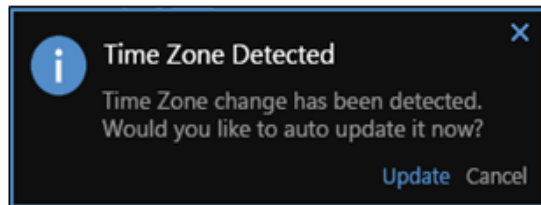

Click **Update**. If the “Auto Update Regional Settings” is enabled, and if there is mismatch in video standard; then a confirmatory message stating “**Changing the configuration will affect the Video Standard and will restart the system! Do you want to continue?**” is displayed. Click **OK** to continue or click **Cancel** to cancel the updation of time zone. If OK is clicked, the system will restart and the time zone will get updated automatically.

Synchronize Camera Time With: Enable the respective option; **Local Time** or **UTC Time**, with which the time of the Camera will be synchronized.

- **Local Time:** Enabling this option will update the time of the camera as per the current time of SATATYA Device. Also, the 'Time zone' of camera will be changed to the Standard time zone ((GMT) CASABLANCA MONROVIA).
- **UTC Time:** Enabling this option will also update the time of the camera as running in SATATYA Device but, it will not affect the time zone of the camera. If the 'Synchronize NVR Time Zone to ONVIF Cameras' option is enabled then current time zone of the camera will also be updated as configured in SATATYA Device.

Synchronize NVR Time Zone to ONVIF cameras: Enable the checkbox to sync Time Zone as well as date & time of NVRX with the connected cameras.



The 'Synchronize NVR Time Zone to ONVIF Cameras' option can not be updated if Local Time is selected to be synchronized with Camera.

Once enabled, the Date & Time along with the Time Zone of connected cameras (added via ONVIF) will get updated as per the current parameters are running in NVRX.

Time Zone: Select the relevant Time Zone based on the location from the drop-down list.

Date: Set the Date by clicking on the calendar button.

Time: Set the Time by clicking on the up-down scroll button.

Set: Click on the Set button to save the date and Time settings.

In the event of selecting the **Auto Synchronize with NTP Server**, check the box to enable this functionality.

Preferred NTP server: You can specify the IP address or host name of the preferred NTP server to be used to update and synchronize System's Real Time Clock periodically at defined time interval. For eg: the server can be Wisconsin, Windows or NIST.

Update: The Update Interval field specifies the time period in hours between successive time synchronizations.

The options available are:

- Every 6 Hours
- Every 12 Hours
- Every 24 Hours

Click on **Save** once done.



Note that the date and time of cameras added through ONVIF in the device will be same as set in the Device Date and Time page.

Daylight Saving Time

Click on the **Configuration** option from the left pane of Device Client. The **Configuration Settings** page appears. Select the **Daylight Saving Time** option from **Basic Settings**. The page appears as shown below.



Enable DST: Select this check box to enable and set the Daylight Saving Time functionality.

Forward Clock: Specify the day when the clock is to be forwarded to increase the daylight time. Select the day by specifying **Month**, **Week** and **Day**. Specify the Time when the clock is to be forwarded. For eg: The clock is forwarded on the first Sunday of October at 6 am as shown in above figure.

Reverse Clock: Specify the day when the clock is to be reversed to normalize the time. Select the day by specifying **Month**, **Week** and **Day**. Specify the Time when the clock is to be reversed. For e.g.: The clock is reversed on the first Sunday of January at 5 am as shown in above figure.

Time Period: Specify the time duration in hh:mm format by which the clock is to be forwarded or reversed. For eg: The clock is forwarded and reversed by 1 hour. The clock will be forwarded to 7 am and reversed to 4 am on the specified days.

Click on **Save** once done.

The Camera Settings option enables the user to define the cameras to be associated with each channel of the SATATYA device. The user can configure the following functionalities:

- “Camera Search”
- “Camera”
- “Stream Settings”
- “Image Settings”
- “Recording/Adaptive Recording Settings”
- “Schedule Snapshot”
- “Image Upload Settings”
- “PTZ Interface”
- “Preset Position”
- “Preset Tour”
- “Audio Settings”
- “Alarm Output”

Camera Search

Click on the Configuration option from the left pane of the Device Client page. The Configuration Settings page appears. Select **Camera Settings** and select **Camera Search**. The Camera Search page appears as shown below:

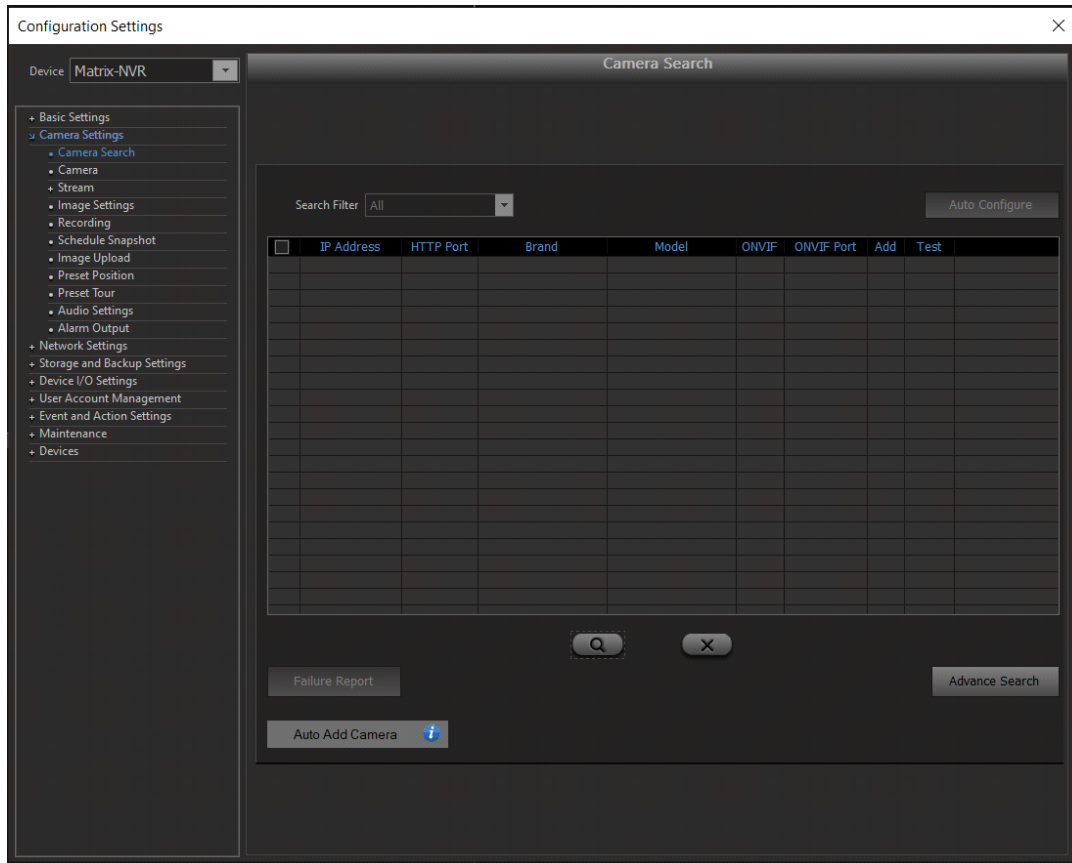

This page allows the user to configure the parameters for the cameras to be added in the SATATYA Device. Follow the steps below to search and configure the parameters for cameras in the network.

[“Step 1: Searching Camera from Network”](#)

[“Step 2: Auto Configuration of Cameras”](#)

This Page also allows the user to add or reject the Matrix IP Camera detected in the network through Camera Initiation.

Step 1: Searching Camera from Network

The user can search the cameras available in the network in two ways: By Simple Search and Advanced Search. Click on the links below to search the cameras using either of the options.

[“Simple Search”](#)



[“Advance Search”](#)

Simple Search

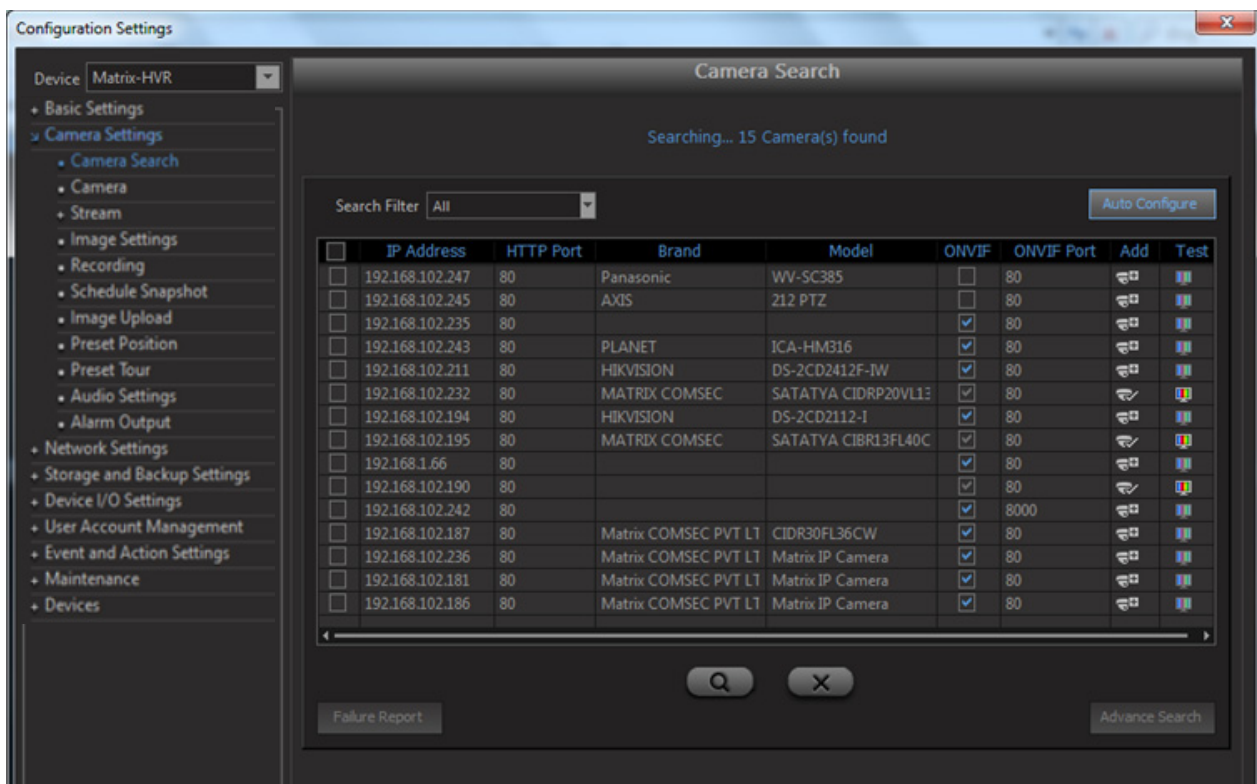

Search: Click on the Search button  to search for the Cameras in the Network. You can select the search filter from the option of All, Added or Not Added.

The Cameras with identified IP Address, Brand Name and Model Name appears in the list as shown below:



If the Camera is already added, then the **Add** column will show status as added with symbol . There will be **Test** button  against the added camera. Click on the Test button to test the Camera.

If the Camera is not added, then click on **Add** button  to add the Cameras.

The **Index** can be selected by clicking the Select Index picklist  and clicking on set button  of the corresponding index from the Camera list window.

Index	IP Address	Camera Name	Status	Set
1	192.168.101.48	Camera-1	Enabled	
2	192.168.111.87	MATRIX COMSEC	Enabled	
3	192.168.111.73	MITR20FL60CWS	Enabled	
4	192.168.111.102	All Color -5MP	Enabled	
5	192.168.111.74	MITR50FL60CWS	Enabled	
6	192.168.111.33	All color-2MP	Enabled	
7	192.168.111.96	192.168.111.96	Disabled	
8	192.168.111.140	MATRIX COMSEC	Enabled	
9		Camera-9	Disabled	
10	192.168.111.123	PTZ 123	Enabled	
11	192.168.111.129	MATRIX COMSEC	Enabled	
12	192.168.111.135	Camera-135	Enabled	
13	192.168.111.102	CamInit 0d:37:51	Enabled	
14	192.168.111.74	CamInit 09:f9:68	Enabled	

If Cameras are **unidentified**, then the **Brand** and **Model** of Camera can be selected from the drop-down list by clicking on the text box.

On Click of the Save button, If ONVIF is not set and brand and model is unidentified then the message appears as shown below:

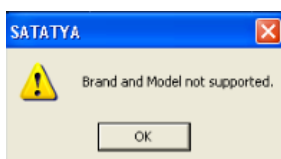

If ONVIF flag is checked and/or Brand name and model name is known/identified then the Camera is allowed to be saved.

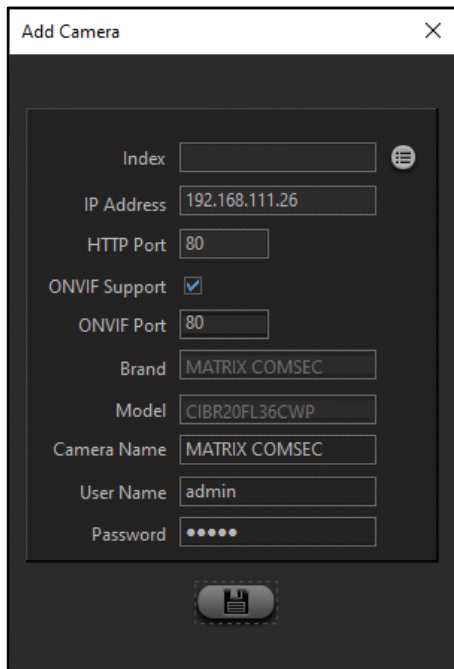

If Cameras are **identified**, then the detected brand name and model name is shown in respective fields. And the Camera is allowed to be saved.

Advance Search

Click on Advance Search button to search for the cameras in other subnet.



IP Address Range: Specify the from and to IP address within which cameras are to be searched.

Camera Brand: Click the text box and select the camera brand from the drop-down list.

HTTP Port: The HTTP port appears as per the camera brand selected.

Username/Password: The Username and Password appears as per the camera brand selected.

Click on **OK** to save the settings.

Step 2: Auto Configuration of Cameras

Select the Camera(s) which you want to auto configure from the search list and click on the **Auto Configure** button as shown below:

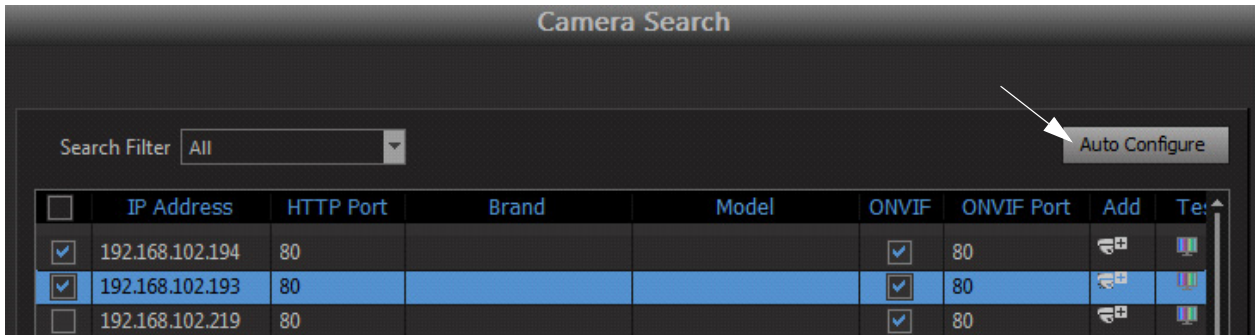

Clicking on the Auto Configure button will open a pop-up window from where you can enter credentials for auto configuration. The screen is shown below:

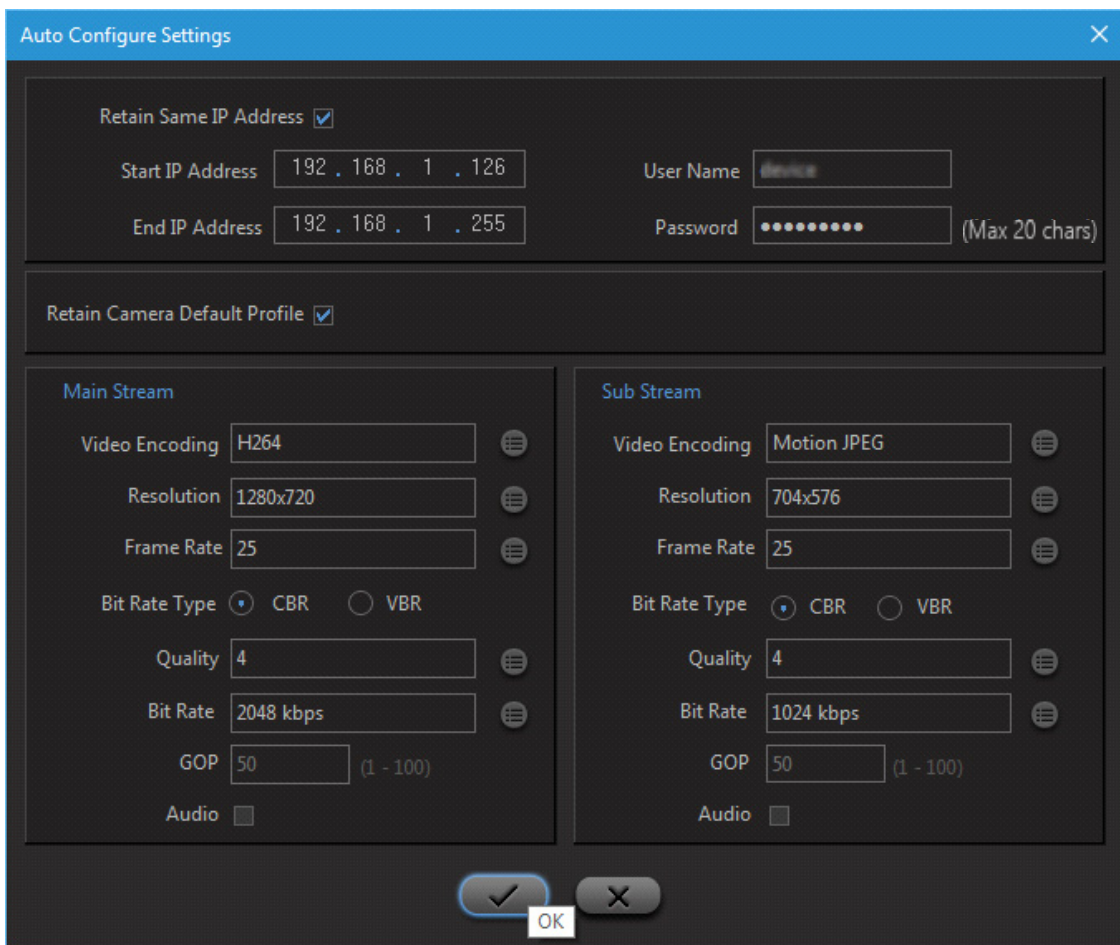

Click on the **OK** button to set the configurations. To know more about Auto Configure feature, [See “Auto Configure” on page 230.](#)



Auto Configuration rights are given to Admin user group only.

Auto Add Camera



1. Auto Add camera feature is supported in all the SATATYA Devices.
2. The feature is configurable using Device Client and Local Client both.

Auto add camera feature allows the user to add the cameras in the Device via Camera Initiation. In this, camera initiates communication with the device client to get added into the device.

Click on the **Auto Add Camera** option and following pop-up will appear.

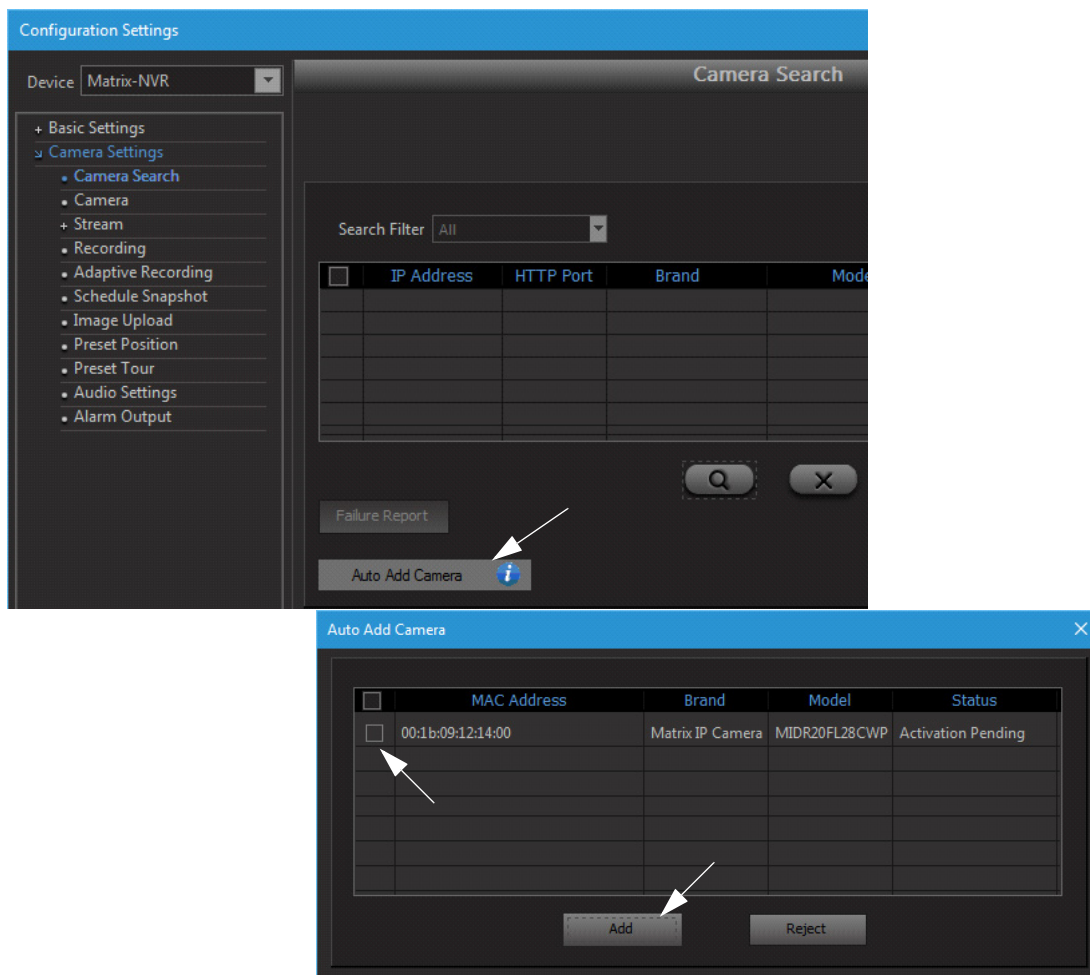

The pop-up window contains the list of the cameras in pending state.



- The list of the camera appears only if the **Auto Add Camera** option is disabled from Basic Settings page. See "Auto Add Camera" on page 232.*

You need to select the camera(s) and click on **Add** button to activate the camera. Click **Reject** to remove the camera from the pending list.

Camera

Click on the **Configuration** option from the left pane of the Device Client page. The **Configuration Settings** page appears. Select **Camera Settings** and Click on **Camera**. The Camera Settings page appears as shown below:

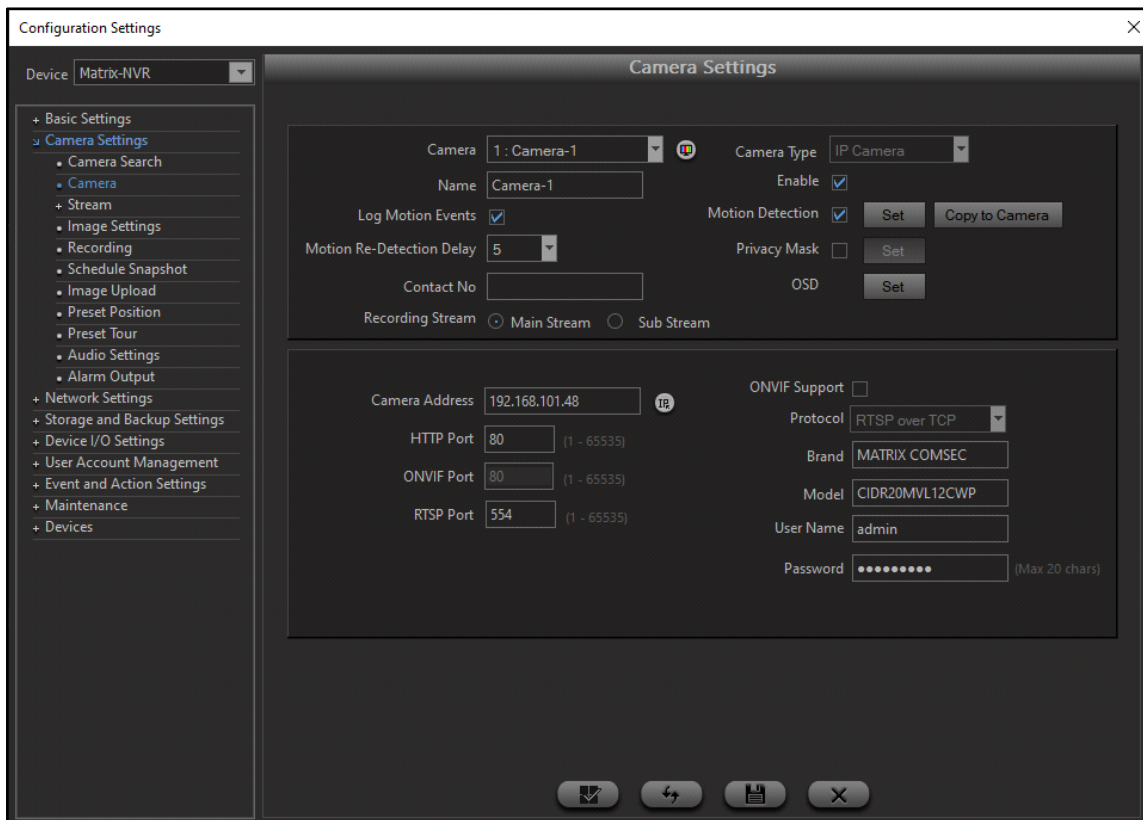

You can add cameras to the SATATYA Device through Camera Search, that is, via Auto Configure and Auto Add Camera and through manually via Brand-Model. For details on Auto Configure and Auto Add Camera, refer to [“Camera Search”](#). You can add cameras manually, either via ONVIF Support or via selecting the Brand and Model, which is explained below.



*If you have added any **Axis** brand camera variant in your device and you wish to upgrade the device to the latest firmware version, that is 8.3.0, the Axis camera will be removed from the channel. You need to add the camera again via ONVIF or Camera Initiation (Brand-Generic). This is applicable to NVRX/NVRX P2 series only.*

Camera: Select the Camera Number from the drop-down list. Click on  button to test the camera. The following screen appears on clicking the test button.

Click on the **Details** button to view the Events and Features supported by that camera as shown below.

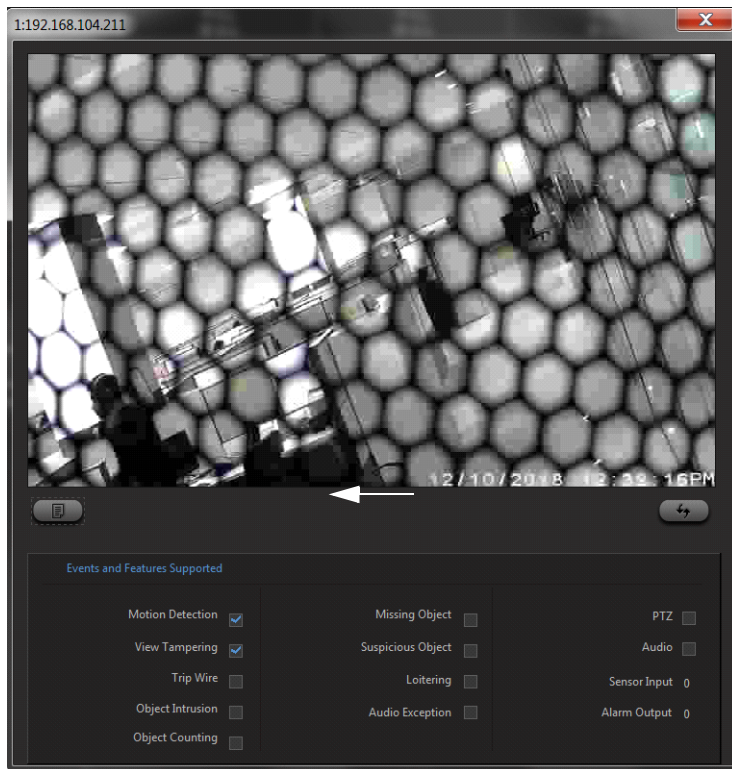

Camera Type: Select the type of Camera i.e. Analog camera or IP camera

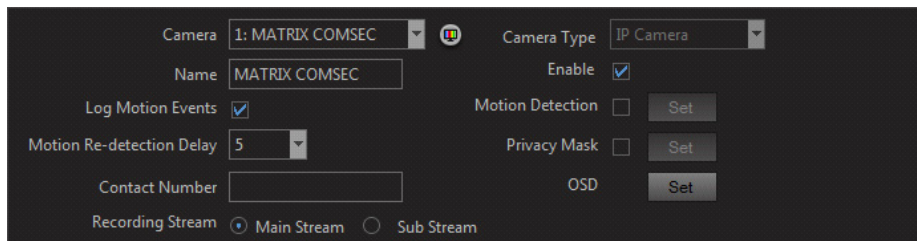

Camera Name: Enter a name for the camera in the Camera Name field.

Enable: Select the Enable check box to activate the channel.

Log Motion Events: Select the **Log Motion Events** check box to generate log of events. The logs will include Motion/No Motion events, depending on the option selected in Event under Motion Detection.



No Motion events in NVRX/NVRX P2 series will be generated only for Matrix camera's with firmware IPCamera_S05_FirmwareV02R12 and later.

No Motion in NVRX/NVRX P2 series is applicable for 2MP/ 5MP Ruggedized and 5MP All Color cameras only when the cameras are added via Camera Initiation or Brand and Model.

Motion Re-detection Delay: Select the delay value after which the motion is to be re-detected.



Motion Re-detection Delay is not applicable when **No Motion** is selected as the **Event** under Motion Detection.

No Motion as Event in NVRX/NVRX P2 series is applicable only for Matrix camera's with firmware IPCamera_S05_FirmwareV02R12 and later.

No Motion in NVRX/NVRX P2 series is applicable for 2MP/ 5MP Ruggedized and 5MP All Color cameras only when the cameras are added via Camera Initiation or Brand and Model.

Contact Number: When any user views the live view using Mobile viewer. If he finds any event occurrence or any security concern then he can make a call to the concerned person to alert or inform regarding event occurred by dialing the specified contact number against the particular channel number.

Recording Stream: Select the recording stream as Main Stream or Sub Stream.

Motion Detection:

In Local Client

Select the Motion Detection check box to enable the event. Click on the **Set** button to define the Zone for the selected camera. The 1x1 monitoring view of the camera appears with the overlying grid as shown.

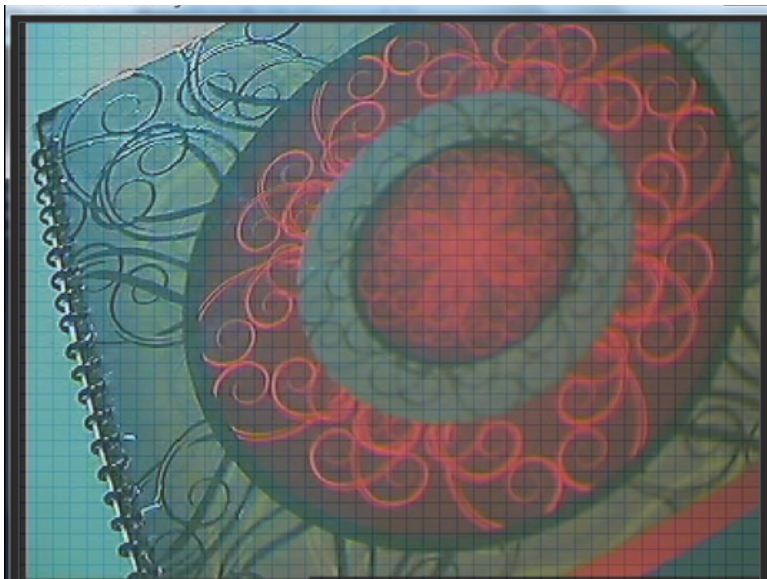

Left click on this window and select the **Set Area** option. Select the square zones in the grid, by left clicking the mouse to define the area. The user can also drag and drop the mouse cursor to define the area.

Right click on the monitoring window to access the following:

- **Event:** Select the **Event** option. The **Select Event** popup appears. Select the desired Event — Motion, No Motion.



No Motion in NVRX/NVRX P2 series is applicable only for Matrix camera's with firmware IPCamera_S05_FirmwareV02R12 and later.

No Motion in NVRX/NVRX P2 series is applicable for 2MP/ 5MP Ruggedized and 5MP All Color cameras only when the cameras are added via Camera Initiation or Brand and Model.

- **Sensitivity:** Select the **Sensitivity** option. The **Select Sensitivity** popup appears. Select the desired level of Sensitivity.
- **Duration:** This is applicable only if you have selected **No Motion** as the **Event**. Select the **Duration** option. The **Duration** popup appears. Enter the desired duration. If for this duration no motion occurs, the No Motion Detection event will be generated. These events will be logged in the system if the **Log Motion Events** check box is enabled.
- **Clear All:** In order to clear the defined motion detection area, right click on the monitoring window and select the **Clear All** option.
- **Exit:** To save the selected zone, right click on the monitoring window again and select **Exit**. The Maintain Changes window appears. Select Yes to save the changes. The system returns to the Detection Settings window.

Select the channels which will start video recording in the event of a motion/no motion being detected in the zone of the selected camera or channel by checking the boxes against the respective channels.

Click on **Save** once done.

If you clear the Motion Detection check box, all the previously configured zones will be cleared (applicable for NVRX/NVRX P2 series only). Make sure you click **Save** to save the settings.

If you wish to set the same area for other cameras, click **Copy >>**.

The screenshot displays the 'Camera Settings' window with the following configuration details:

- Camera:** 5 : 192.168.111.117
- Name:** 192.168.111.117
- Log Motion Events:**
- Motion Re-Detection Del.:** 5 (5-30)
- Contact No:** [Empty field]
- Recording Stream:** Main Sub
- Type:** IP Camera
- Enable:**
- Motion Detection:** Set >> Copy >>
- Privacy Mask:** Set >>
- OSD:** Set >>
- Camera Address:** 192.168.111.117
- HTTP Port:** 80 (1-65535)
- ONVIF Port:** 80 (1-65535)
- RTSP Port:** 554 (1-65535)
- URL:** [Empty field]
- ONVIF Support:**
- Protocol:** RTSP over TCP
- Brand:** MATRIX COMSEC
- Model:** CIBR50MVL12CWF
- Username:** admin
- Password:** ***** (Max 20 chars)

Buttons at the bottom: Default, Refresh, Save

The **Copy to Camera** window opens.

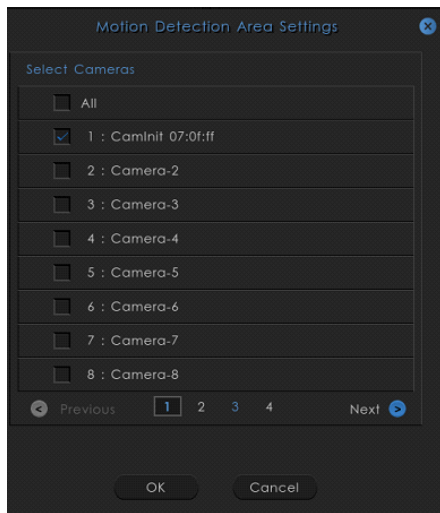

Select the check boxes of the desired camera's or select the **All** check box to copy it across all the cameras.

Click **Save** or click **Cancel** to abort and exit.

In Device Client

Select the Motion Detection check box to enable the event. Click on the **Set** button to define the Motion Zone for the selected camera. The **Motion Detection Area Settings** window opens.

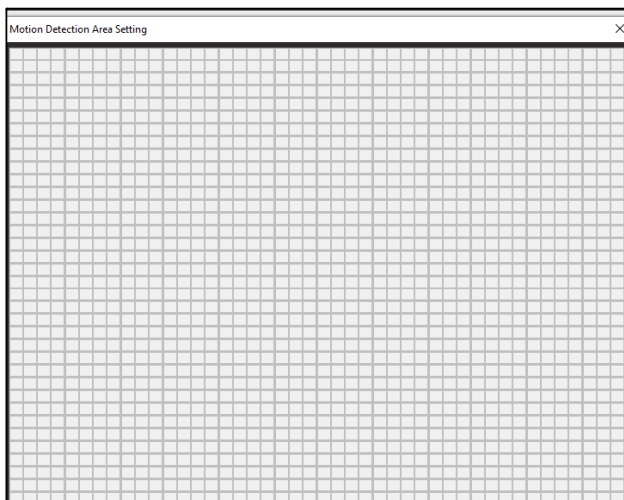

Drag and drop the mouse cursor to define the area.

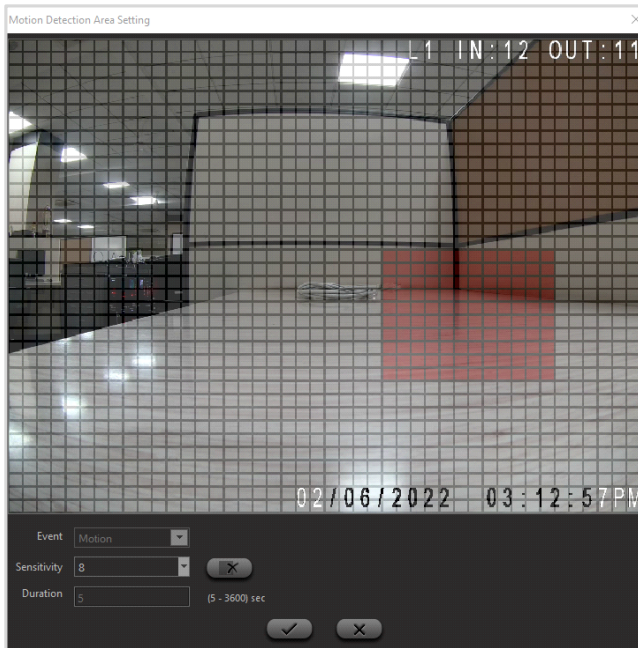

- Select the desired **Event** — Motion, No Motion.
- If you select the **Event** as **No Motion**, you need to set the **Duration**.





No Motion in NVRX/NVRX P2 series is applicable only for Matrix camera's with firmware IPCamera_S05_FirmwareV02R12 and later.

No Motion in NVRX/NVRX P2 series is applicable for 2MP/ 5MP Ruggedized and 5MP All Color cameras only when the cameras are added via Camera Initiation or Brand and Model.

Motion Re-Detection Delay is not applicable when No Motion is selected as Event.

Set the desired level of **Sensitivity**.

Set the **Duration**. This is applicable when you select the Event as No Motion. If no motion occurs until the configured duration, No Motion Detection event will be generated. These events will be logged in the system if the **Log Motion Events** check box is enabled.

Click **Save**  to save the settings or click **Cancel**  to abort and exit.

Click **Clear**  to clear the selected area.

If you clear the Motion Detection check box, all the previously configured zones will be cleared (applicable for NVRX/NVRX P2 series only). Make sure you click **Save** to save the settings.

If you wish to set the same area for other cameras, click **Copy to Camera**.

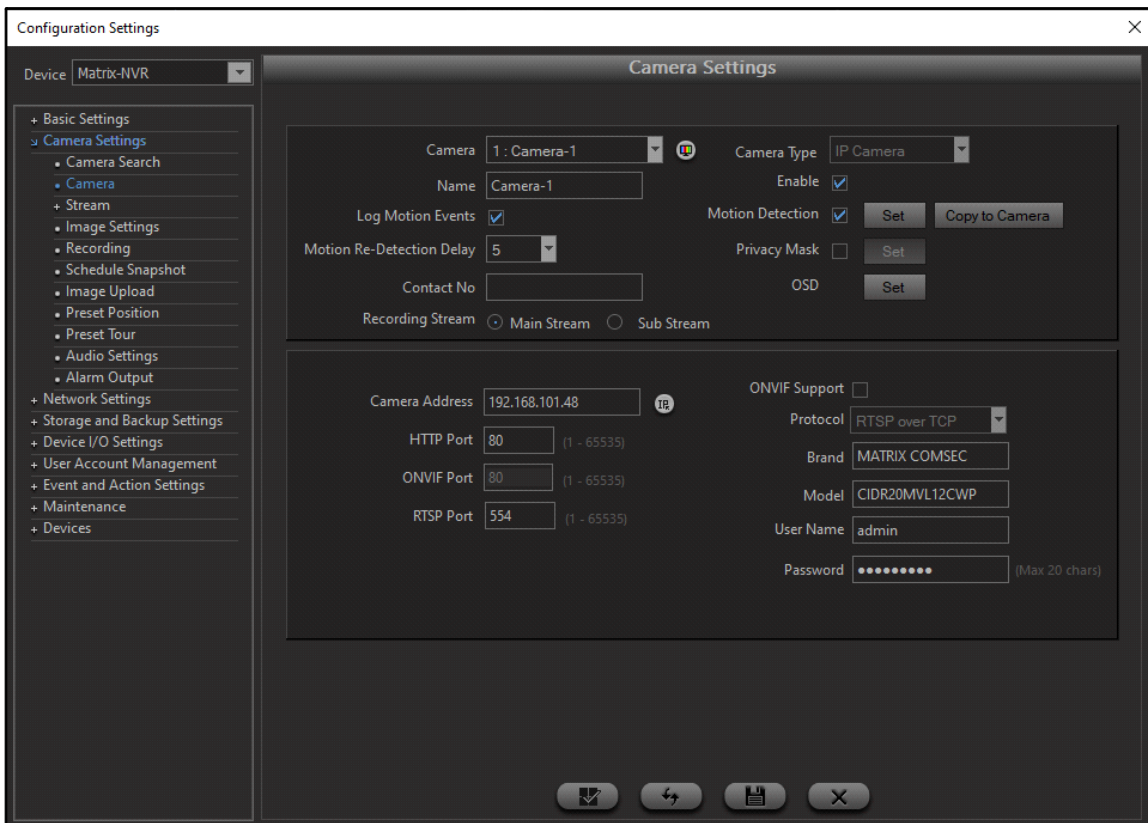

The **Copy to Camera** window opens.

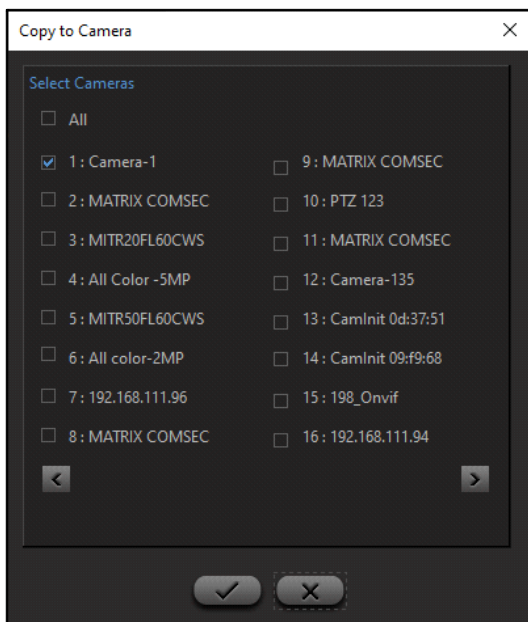

Select the check boxes of the desired camera's or select the **All** check box to copy it across all the cameras.



Click **Save** or click **Cancel** to abort and exit.



If any failures occur during copying, the events will be generated. For details, refer to “[Event Search](#)”.

Privacy Mask Settings: Select the **Privacy Mask** check box and click **Set** to enable the Privacy Mask functionality for the selected channel. The system will display a 1x1 monitoring window of the selected channel.



- Click the right button and drag the mouse cursor to define the area to be masked. After selecting the area release the mouse button. Click on the **OK**  button to save the configurations.
- To delete the masked area, select that area and click on the **Clear**  button.
- To discard the configurations, click on **Cancel**  button.



Privacy Mask can be configured only when the Camera is added via Brand Model or Camera Initiation. It is not supported when the Camera is added via ONVIF.

Maximum four Privacy Mask zones are supported by Device Client and Local Client, while the user is allowed to configure the zones as supported by the camera.

For the following camera variants, maximum eight Privacy Mask zones are supported by Device Client and Local Client for NVRX/NVRX P2 series:

- *Matrix 8MP camera's with firmware IPCamera_S05_FirmwareV02R12.3 and later.*
- *2MP and 5MP Ruggedized camera's with firmware IPCamera_S05_FirmwareV03R01 onwards.*
- *5MP All Color camera's with firmware IPCamera_S05_FirmwareV03R03 onwards.*

For other Matrix IP camera's maximum 3 Privacy Mask zones are supported.

OSD: Click on Set button to configure the OSD settings.

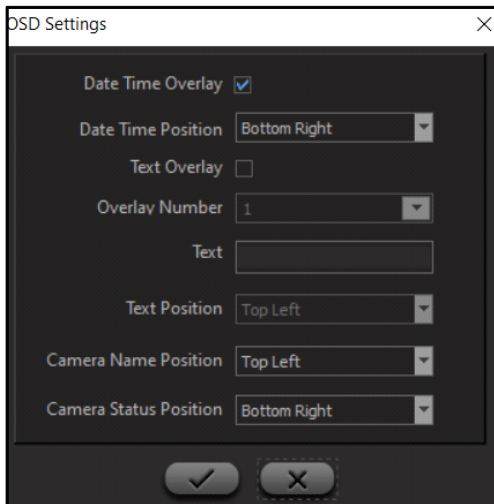

- **Date-Time Overlay:** Check the box to display date and time over the monitoring window of the selected channel.
- **Date-Time Position:** Select the position for date-time from the drop-down list.
- **Text Overlay:** Check the box to display text over the monitoring window for the selected channel.



Multiple Overlay options can be configured only when the camera is added via Brand Model or Camera Initiation. It is not supported when the camera is added via ONVIF.

*For the following camera variants, maximum six Text Overlay options are supported in the NVRX/NVRX P2 series. Hence, **Overlay Number** is only applicable to these camera's.:*

- *Matrix 8MP camera's with firmware IPCamera_S05_FirmwareV02R12.3 and later.*
- *2MP and 5MP Ruggedized camera's with firmware IPCamera_S05_FirmwareV03R01 onwards.*
- *5MP All Color camera's with firmware IPCamera_S05_FirmwareV03R03 onwards.*

For other Matrix IP camera's one Text Overlay is supported.

- **Overlay Number:** Select the desired number for which you wish to set the Text Overlay from the drop-down list. You can configure Text and Text Position for each Overlay Number.
- **Text:** Specify the text to be displayed over the channel window.
- **Text Position:** Select the position for text from the drop-down list.
- **Camera Name Position:** Select the position of Camera Name on the display screen from the drop-down list.
- **Camera Status Position:** Select the position of Camera Status on the display screen from the drop-down list.
- Click on **OK** to save the settings.

IP Camera

Camera Address: Specify the camera address in this field which can be either the IP address or Domain Name as set on the camera.

ONVIF Support: Check the box to enable the communication with connected camera based on ONVIF protocol. If it is enabled then Brand Name and Model Name will be defined by the system once it is received from connected ONVIF camera.

Protocol: After enabling ONVIF Select the protocol RTSP over TCP or RTSP over UDP for communication.

HTTP Port: Specify the HTTP listening port of the camera. If ONVIF is enabled, this field will be disabled.



HTTP Port will be disabled for NVRX/NVRX P2 series only.

ONVIF Port: Specify the ONVIF listening port of the camera.

RTSP Port: Specify the RTSP listening port of the camera as and when required.

Brand: Click the text box and select the desired camera brand from the drop-down list. Make sure ONVIF is disabled.

Model: Click the text box, the models will be displayed in the drop-down list as per the selected Brand. Then, select the desired camera model.

User Name: Specify the User Name as set on the camera for authentication.

Password: Specify the password as set on the camera for authentication.

If you change the Username or Password, the system will verify the credentials. If the credentials are incorrect, then the Live View will stop.

In the event of defining a generic camera, select the Brand as Generic and then select the **HTTP, RTSP UDP** or **RTSP TCP** option from the list of the Model field. Specify the HTTP URL or the RTSP URL depending on the camera model in the **URL** field.

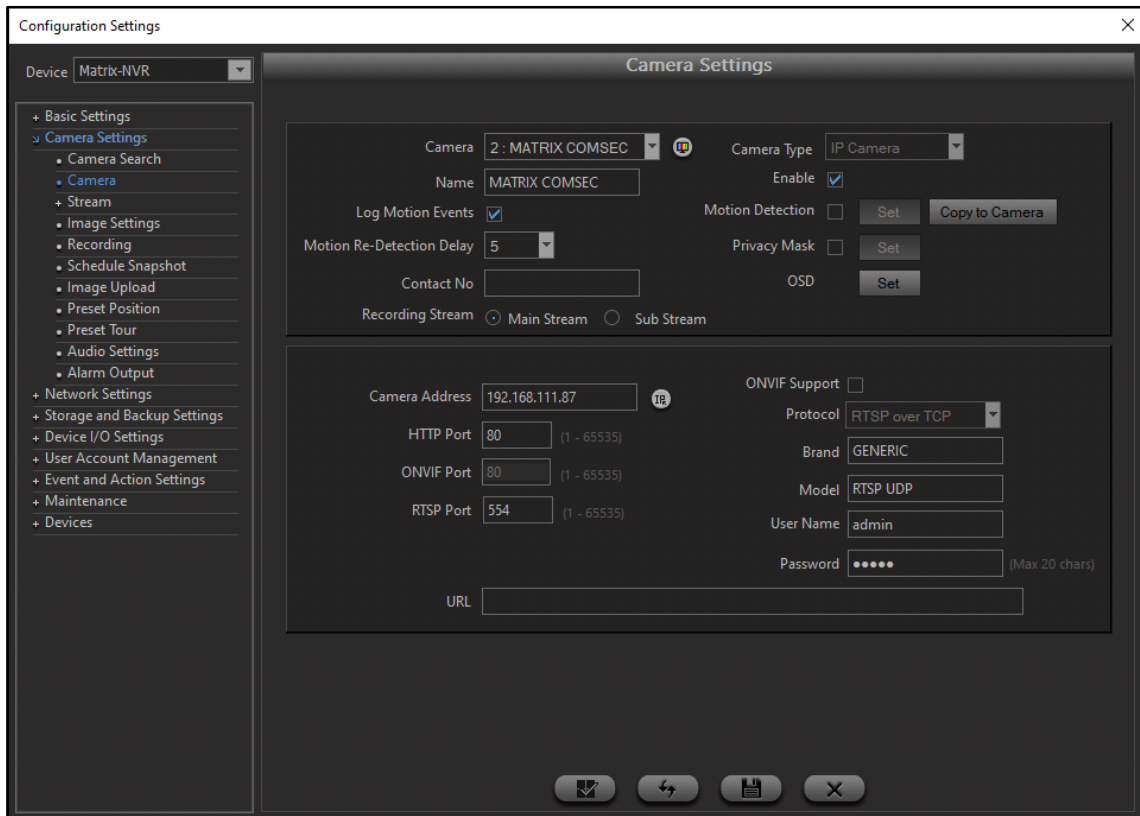

Analog Camera

If Analog Camera is added then following settings can be done.

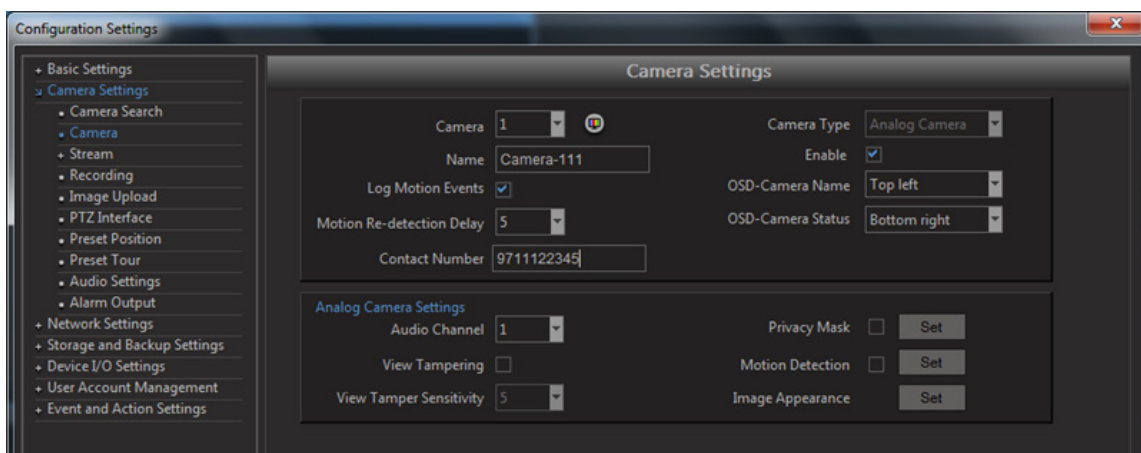

View Tamper Detection

This functionality detects events like covering the camera or flashing a light at the camera etc. Check the box to enable this event for the specified channel.

View Tamper Sensitivity

Set the detection sensitivity for the specified channel from 1 to 10 (where 10 is for highest sensitivity). Select the channels which will start video recording in the event of a view tamper being detected on this channel by checking the boxes against the respective channels.

Click on **Save** once done.

Audio Channel

Select the Audio channel to be linked to the selected camera channel from the drop-down list.

Image Appearance Settings

Click on **Set** button to configure the Image appearance settings

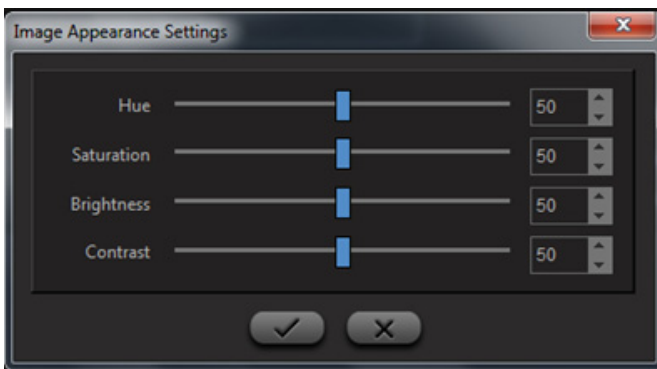

The user can adjust the Hue, Saturation, Brightness and Contrast of the live video for day and night profile by using the up-down arrow buttons.

Click on **Save** button to save the settings.

Stream Settings

Click on the Configuration option from the left pane of Device Client. The Configuration Settings page appears. Click on Camera Settings. Select the Stream option. The Stream Settings page appears as shown below:

Analog Stream Settings

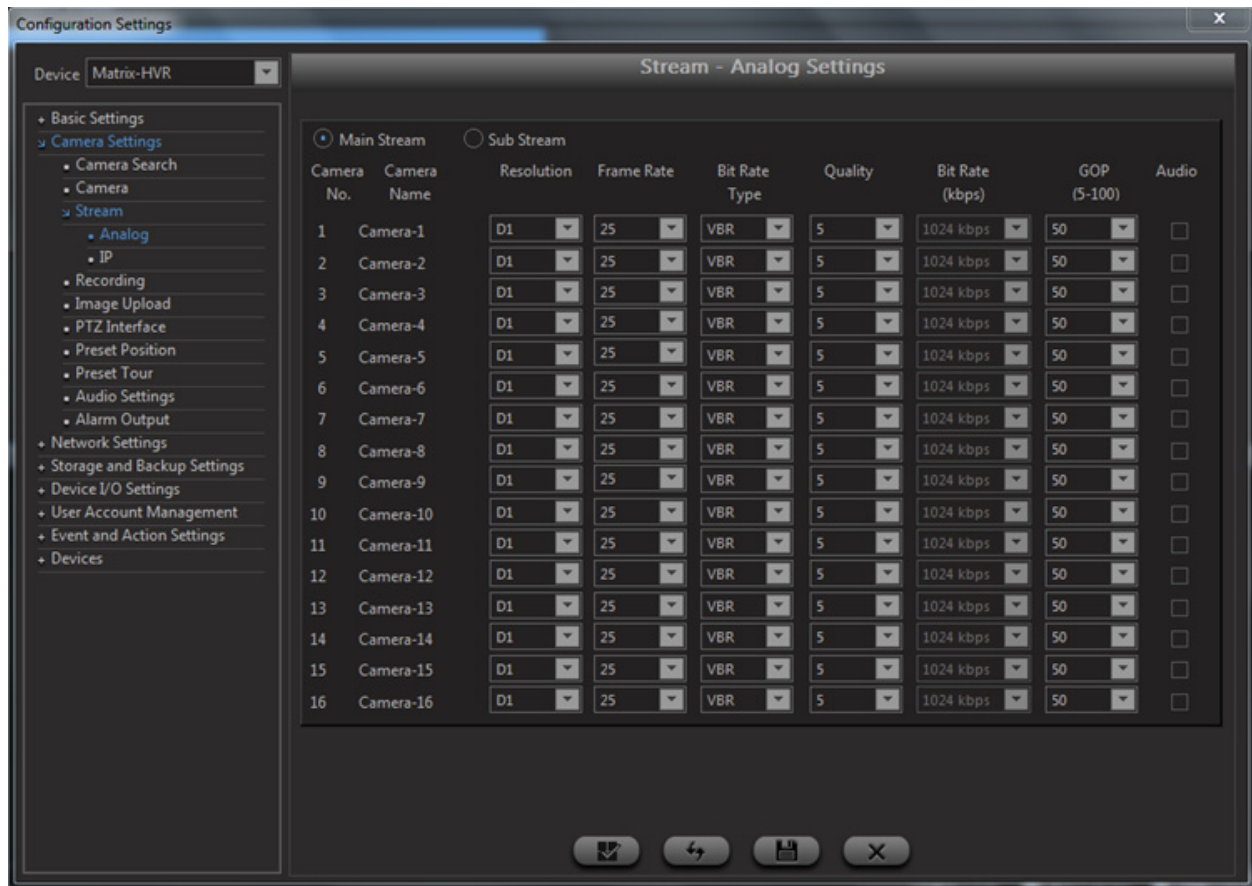

Select the **Main Stream** or **Sub Stream** and set the streaming parameters for the defined cameras.

Resolution: Select the required resolution from the drop-down list.

FrameRate: Select the video frame rate from the drop-down list. The maximum frame rate that can be set for a camera is 30.

Bit Rate Type: Select the desired Bit Rate Type as **CBR** (Constant Bit Rate) or **VBR** (Variable Bit Rate).

Quality: Select the video quality from the drop-down list. Level 1 is minimum and Level 100 is maximum Quality Level. Selecting higher settings will give you higher quality video, at the expense of network bandwidth and disk storage capacity.

Bit Rate (kbps): Select the appropriate **Bit Rate** from the drop-down list. The options available are: Low, Average, High and Highest.

GOP: Select the GOP (Group of Pictures) value from 1 to 100 from the drop-down list. The GOP is the ratio of P Frame and I Frame for individual Camera Channels.

Click on **Save** once done.

IP Stream Settings in Local Client

Stream Settings ✕

Camera 1 : CamInit 07:0f:ff ▾

Main Stream		Sub Stream	
Profile	1	Profile	2
Video Encoding	H264	Video Encoding	H264
Resolution	640x480	Resolution	704x576
Frame Rate	29	Frame Rate	25
Bit Rate Type	<input checked="" type="radio"/> CBR <input type="radio"/> VBR	Bit Rate Type	<input type="radio"/> CBR <input checked="" type="radio"/> VBR
Bit Rate	1024 kbps	Bit Rate	1024 kbps
Quality	4	Quality	4
GOP	50 (1-100)	GOP	50 (1-100)
Audio	<input type="checkbox"/>	Audio	<input type="checkbox"/>

Copy to Camera >> Copy to Camera >>

Default Refresh Save

IP Stream Settings in Device Client

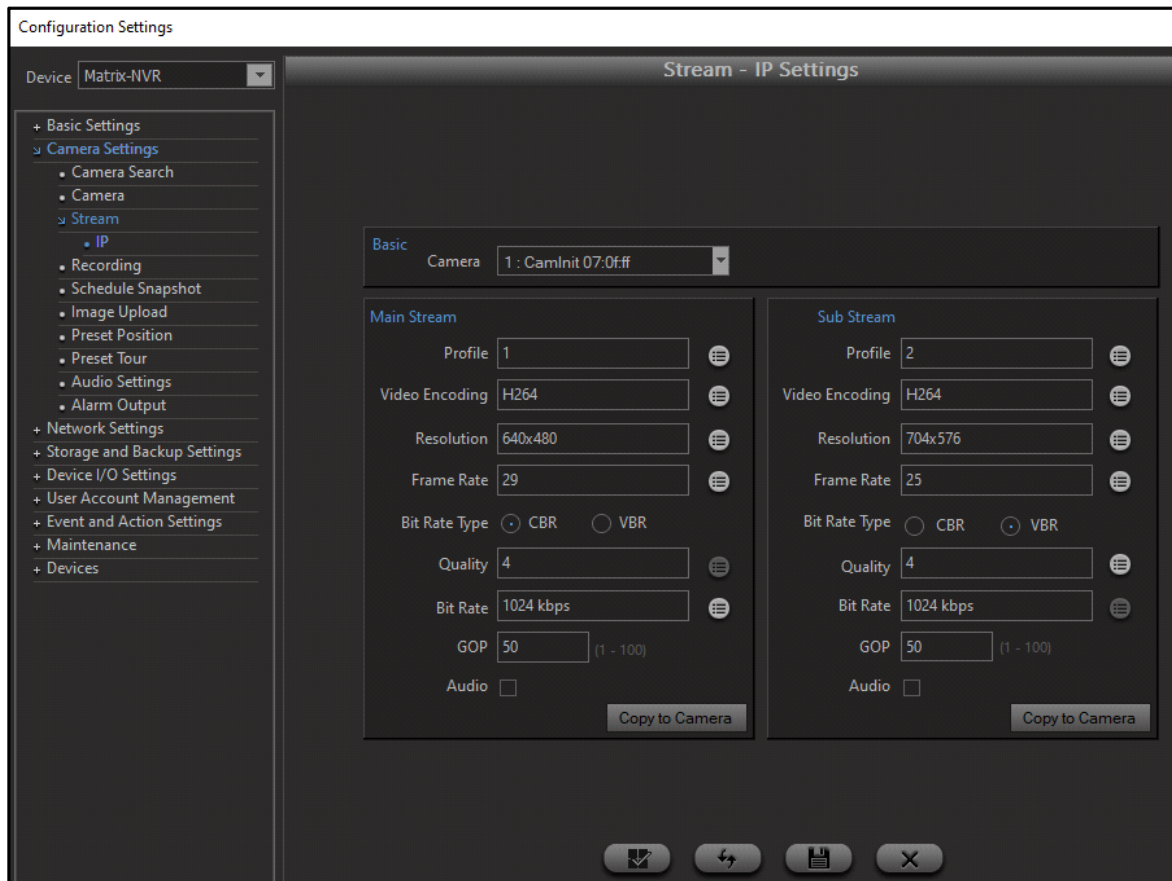

This option enables the user to set the streaming parameters for the defined cameras.

Camera: Select the Camera from the drop-down list.

Profile: For Main stream default Profile is Profile1 and for Sub Stream (if available) it is Profile2. The Profiles are configured in the camera web page and can be selected here. The parameters set from stream profile page will be updated on the camera.

Video Encoding: Click the picklist and double-click to select the desired video encoding mode. The options define the quality of video encoding. H.265 gives superior video quality as compared to H.264 but, by using more bandwidth.

Resolution: Click the picklist and double-click to select the desired resolution.



The stream resolution of selected IP Camera will display in the Resolution list. In case if the user has configured the ROI (Region Of Interest) into the running stream profile of IP Camera then, the Stream resolution of that particular stream will display into the resolution list.

The custom resolution of minimum 64pixels and maximum 8192pixels can be played into the Live View.

The VGA resolution, that is 640x480 is supported in all Matrix Cameras supported by NVR/NVRX/NVRX P2, except the following:

- SATATYA CIBR13FL40CW
- SATATYA CIDR13FL40CW
- SATATYA CIDRP20VL130CW
- SATATYA CIBR30FL36CG
- SATATYA CIBR30FL60CG
- SATATYA CIDR30FL36CW
- SATATYA CIDR30FL60CW

Frame Rate: Click the picklist and double-click to select the desired Frame Rate. The range of frame rate that can be set for a camera is 1 to 30, for cameras added via Brand-Model and Camera Initiation. In NVRX/NVRX/NVRX P2 when cameras are added via ONVIF, the range of frame rate that can be set is 1 to 64. The range for cameras added via ONVIF will differ. It will depend on the frame rate range supported by the camera.



2MP Ruggedized cameras with firmware IPCamera_S05_FirmwareV03R01 and later support Frame Rate range 1 to 60, added via any method. This is applicable for NVRX/NVRX P2 series only.

Bit Rate Type: Select the Constant Bit Rate (CBR) or Variable Bit Rate (VBR).

Quality: Click the picklist and double-click to select the desired video quality. Selecting higher settings will give you higher quality video, at the expense of network bandwidth and disk storage capacity.

Bit Rate: Click the picklist and double-click to select the desired Bit Rate.

GOP: Specify the number of Group of Pictures (GOP).

Audio: This option allows the user to activate or inactivate Audio in synchronization with the video for stream type of selected camera.



Audio will function only if supported by the camera.

Copy to Camera: You can copy the settings of the Main Stream as well as the Sub Stream to other camera's. To do so, click the respective **Copy to Camera** button.

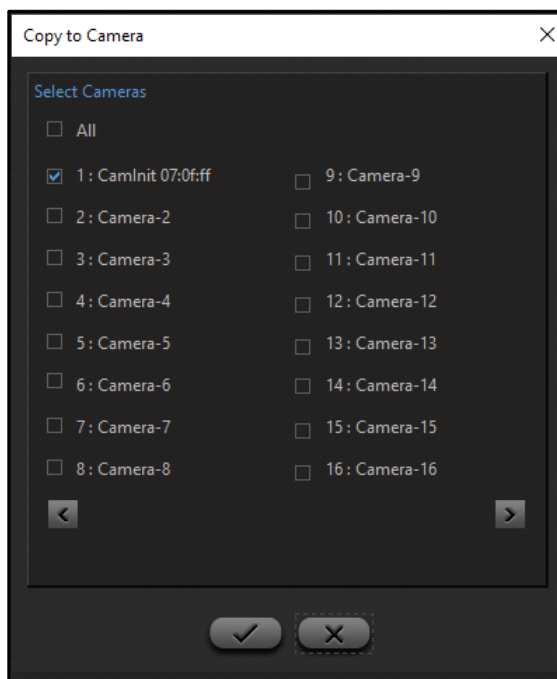

The **Copy to Camera** window opens.

Select the check boxes of the desired camera's or select the **All** check box to copy it across all the cameras.

Click **Save** or click **Cancel** to abort and exit.

Click on **Save** to save all the Stream Settings.



If any failures occur during copying, the events will be generated. For details, refer to ["Event Search"](#).

Image Settings

Image Settings is supported for cameras added via **Brand & Model**, **Camera Initiation**, and **ONVIF**.

- Refer ["Brand & Model and Camera Initiation"](#) for **Image Settings** of **Brand & Model** and **Camera Initiation**.
- Refer ["ONVIF"](#) for **Image Settings** of **ONVIF**.

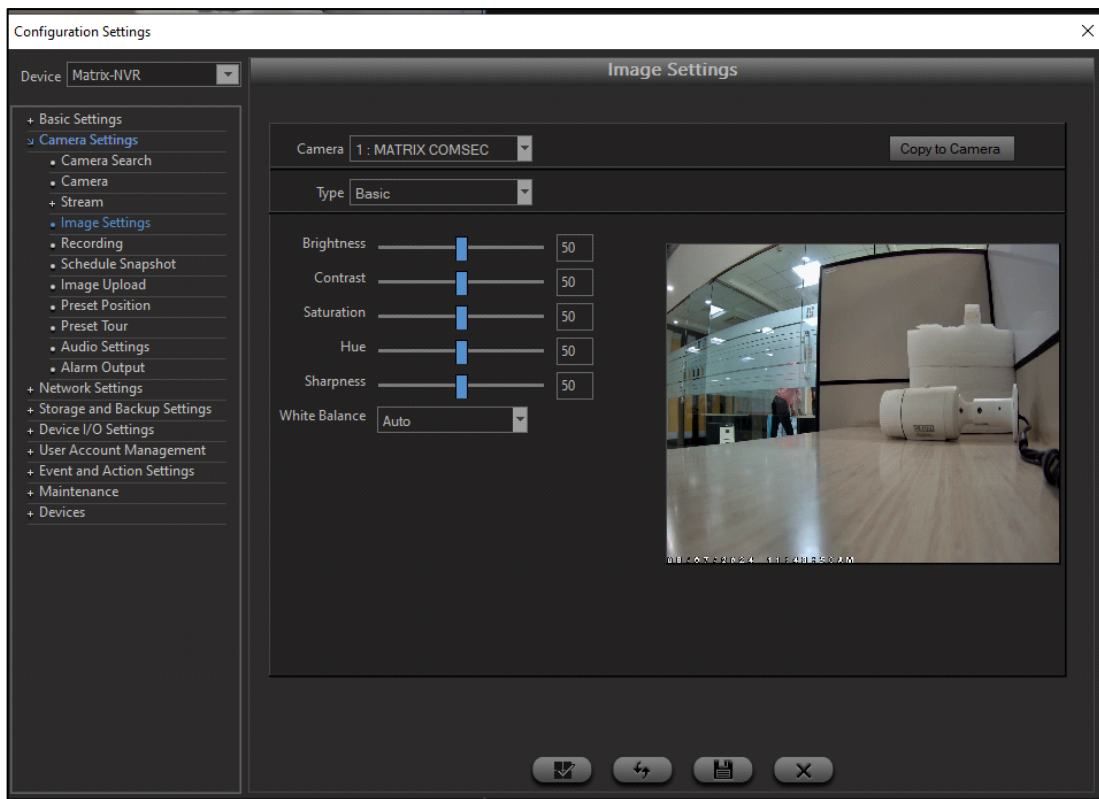

Image Settings are supported in NVRX/NVRX P2 variants in Matrix IP camera's with firmware:

- *IPCamera_S05_FirmwareV03R01 and later*
- *IPCamera_S02_FirmwareV03R01 and later*

Brand & Model and Camera Initiation

Click on the **Device Configuration** option from the left pane of the Device Client page. The **Configuration Settings** page appears. Select **Camera Settings** and click **Image Settings**.



- **Camera:** Select the Camera number from the drop-down list for which you want to view and edit the image settings.
- **Type:** Select the Type of settings you wish to configure from the drop-down list — “Basic” or “Advanced”.

Basic

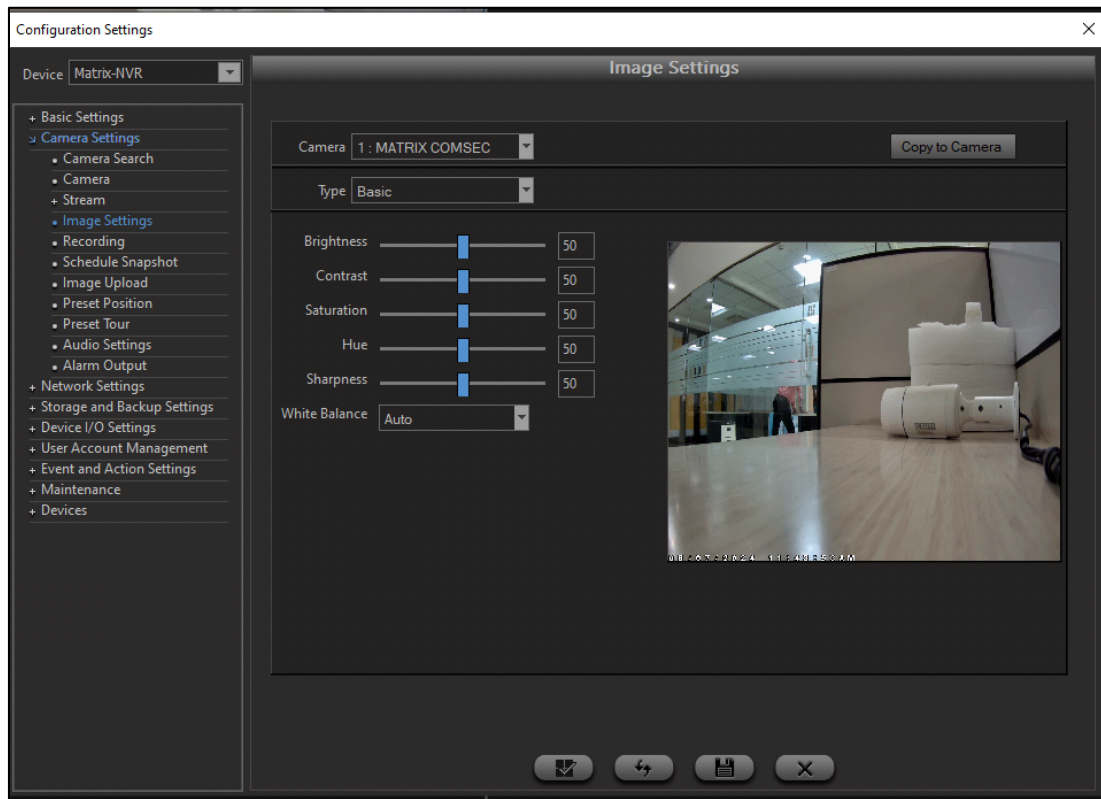

- **Brightness:** To configure the overall lightness of the image drag the slider to the desired position or enter the desired value in the adjoining text-box. Valid Range: 0 - 100.
- **Contrast:** To configure the difference in color and light between objects or regions drag the slider to the desired position or enter the desired value in the adjoining text-box. Valid Range: 0 - 100.
- **Saturation:** To configure the colorfulness of the image drag the slider to the desired position or enter the desired value in the adjoining text-box. Valid Range: 0 - 100.
- **Sharpness:** To configure the details of the image by sharpening the edges in the image drag the slider to the desired position or enter the desired value in the adjoining text-box. Valid Range: 0 - 100.
- **White Balance:** To adjust the color temperature according to the environment select the desired mode from the drop-down list — **Auto**, **Fluorescent**, **Incandescent** or **Sunny**.

Advanced

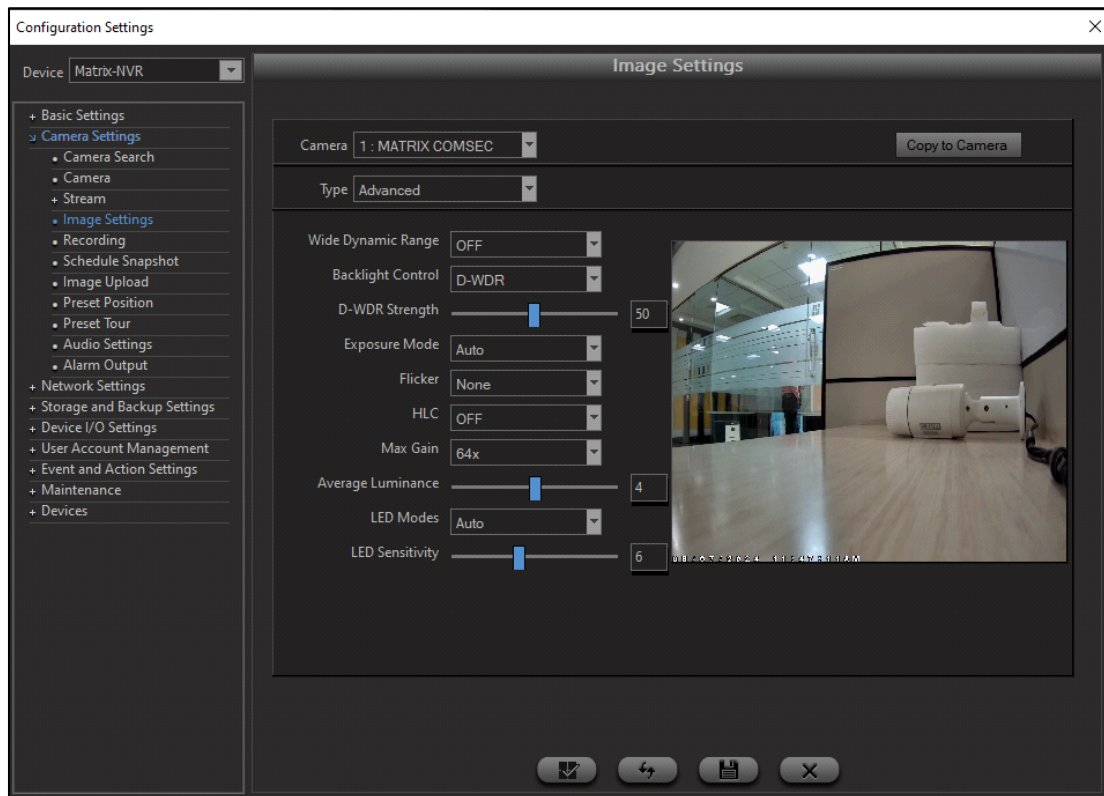

- **Wide Dynamic Range:** To adjust the dark and bright regions within the same image select the desired option from the drop-down list — **Off, Manual** or **Auto**.

If you select **Manual** as the **Wide Dynamic Range** option, you must configure the following:

- Exposure Ratio Mode
- WDR Strength
- Exposure Mode
- LED Mode
- LED Sensitivity

If you select **Auto** as the **Wide Dynamic Range** option, you must configure the following:

- WDR Strength
- Exposure Mode (this option will be set as Auto, automatically and you cannot edit the same)
- LED Mode
- LED Sensitivity

If you select **Off** as the **Wide Dynamic Range** option, you must configure the following:

- Backlight Control
- Exposure Mode
- LED Mode
- LED Sensitivity

- **WDR Strength:** This will only be displayed when **Wide Dynamic Range** is selected as **Manual** or **Auto**. To control dynamic range present within the same image drag the slider to the desired position or enter the desired value in the adjoining text-box. Valid Range: 1 - 100.

- **Backlight Control:** This will only be displayed when **Wide Dynamic Range** is selected as **Off**. To control the backlight of the image select the desired mode from the drop-down list — None, BLC or D-WDR.
- **BLC:** It is a technology which optimizes the light levels to provide the best image of observed objects given the lighting conditions at that moment. This makes it easy to identify the object in focus even when there is excessive light coming from behind the object.
- **D-WDR:** Digital WDR dynamically controls the range of brightness and darkness present in the scene to provide a better view.

If you select **D-WDR** as the **Backlight Control** option, you must configure the following:

- WDR Strength
- Exposure Mode
- LED Mode
- LED Sensitivity

If you select **BLC/None** as the **Backlight Control** option, you must configure the following:

- Exposure Mode
- LED Mode
- LED Sensitivity

- **D-WDR Strength:** This will be displayed when **Wide Dynamic Range** is selected as **Off** and **Backlight Control** is selected as **D-WDR**.

To control dynamic range of brightness and darkness present in the scene to provide better view drag the slider to the desired position or type value in the adjoining text-box. Valid Range: 1 - 100.

- **Exposure Ratio Mode:** This will only be displayed when **Wide Dynamic Range** is selected as **Manual**. Select the Exposure Ratio Mode from the drop-down list — **Auto** or **Manual**.
- **Exposure Ratio:** This will only be displayed when Exposure Ratio Mode is selected as **Manual**. You can adjust the ratio manually to set the brightness and darkness depending upon the scene to provide a better view.

If the scene consists more dark regions, then higher exposure ratio value is recommended.

If the scene consists equal amount of dark and bright regions, then moderate exposure value is recommended.

If the scene consists more of bright region, then lower exposure ratio value is recommended.

Drag the slider towards the left to decrease the exposure ratio and drag the slider to the right to increase the exposure ratio. Alternatively, you can also enter the value directly in the box. Valid Range: 2 - 64.

- **Exposure Mode:** Select the Exposure Mode from the drop-down list — **Auto** or **Manual**.



*If you select **Auto** as the **Wide Dynamic Range** option, **Exposure Mode** will be set as **Auto** automatically and you cannot change it.*

If you select **Auto**, configure the following:

- **Flicker:** Select the Flicker value from the drop-down list — None, 50Hz, 60Hz, Auto — to avoid flickering in the video. Flicker is produced due to mismatch between frequency of exposure and light.

- If you select **Flicker** as 50Hz/60Hz, configure the **Strength**. Drag the slider towards the left to decrease the strength and drag the slider to the right to increase the strength. Alternatively, you can also enter the value directly in the box. Valid Range: 0 - 10.



Flicker Strength is applicable only when the camera is added via Brand and Model.

- **HLC**: This will only be displayed when **Wide Dynamic Range** is selected as **Off**. HLC controls the over exposed light coming to the lens and as a result, the image becomes more clear. The intensity of reducing heavy light will be more for High HLC value and less for Low HLC value. Medium HLC value gives moderate reduction of over light exposure.

Select the HLC from the drop-down list — Off, High, Medium, Low.



HLC is applicable only when the camera is added via Brand and Model.

- **Max Gain**: This defines the maximum gain that can be applied in Auto mode depending upon the light conditions. Select the Max Gain from the drop-down list — 16x,32x, 48x,64x,96x,128x.
- **Average Luminance**: This is used to set the brightness at the sensor level. Drag the slider towards the left to decrease the gain and drag the slider to the right to increase the gain. Alternatively, you can also enter the value directly in the box. Valid Range: 1 - 7.

If you select **Manual**, configure the following:

- **Time**: Configure the shutter time in specified range. More the shutter time, more the image clarity. Valid Range: 10 - 66666.



Time is applicable only when the camera is added via Brand and Model.

- **Gain**: The gain sets the voltage of pixels on the CMOS sensor. Depending upon the gain configured, amplification of the signals is done. It is suitable for rooms with changing lightings, wherein particularly dark areas are brightened. Drag the slider towards the left to decrease the gain and drag the slider to the right to increase the gain. Alternatively, you can also enter the value directly in the box. Valid Range: 0 - 100.
- **Iris**: Iris is a part of the camera that controls the amount of light to be passed through the lens for obtaining good quality image. Drag the slider towards the left to decrease the iris and drag the slider to the right to increase the iris. Alternatively, you can also enter the value directly in the box. Valid Range: 0 - 4.
- **LED Modes**: The function of the LED is to adjust the amount of light reaching the light sensor defined for the night mode. If the light reduces the LED turns on and when it reaches the set value it turns off. Click the desired option — **Auto**, **Always ON**, or **Always OFF**. Default value is Auto.
- **LED Sensitivity**: To adjust the sensitivity of light sensor drag the slider to the desired position or enter the desired value in the adjoining text box. Valid Range: 0 - 15.

To configure the PAN, Tilt and/or Zoom settings of the camera, refer to "[Preset Position](#)".

Click **Save** to save all the Image Settings. The preview of the image is visible as per the settings done in the same window.



Preview will be visible only in the Device Client.

Click **Cancel** to abort and exit.

Copy to Camera: You can copy the images settings of a camera to other cameras. To do so, click the respective **Copy to Camera** button.

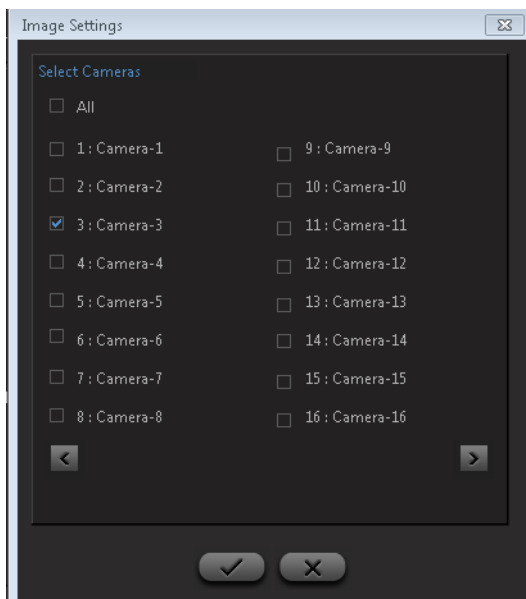

- The **Copy to Camera** window opens.
- Select the check boxes of the desired cameras or select the **All** check box to copy it across all the cameras.
- Click **OK** to copy all the Settings to the other cameras or click **Cancel** to abort and exit.

ONVIF

Click on the **Device Configuration** option from the left pane of the Device Client page. The **Configuration Settings** page appears. Select **Camera Settings** and click **Image Settings**.

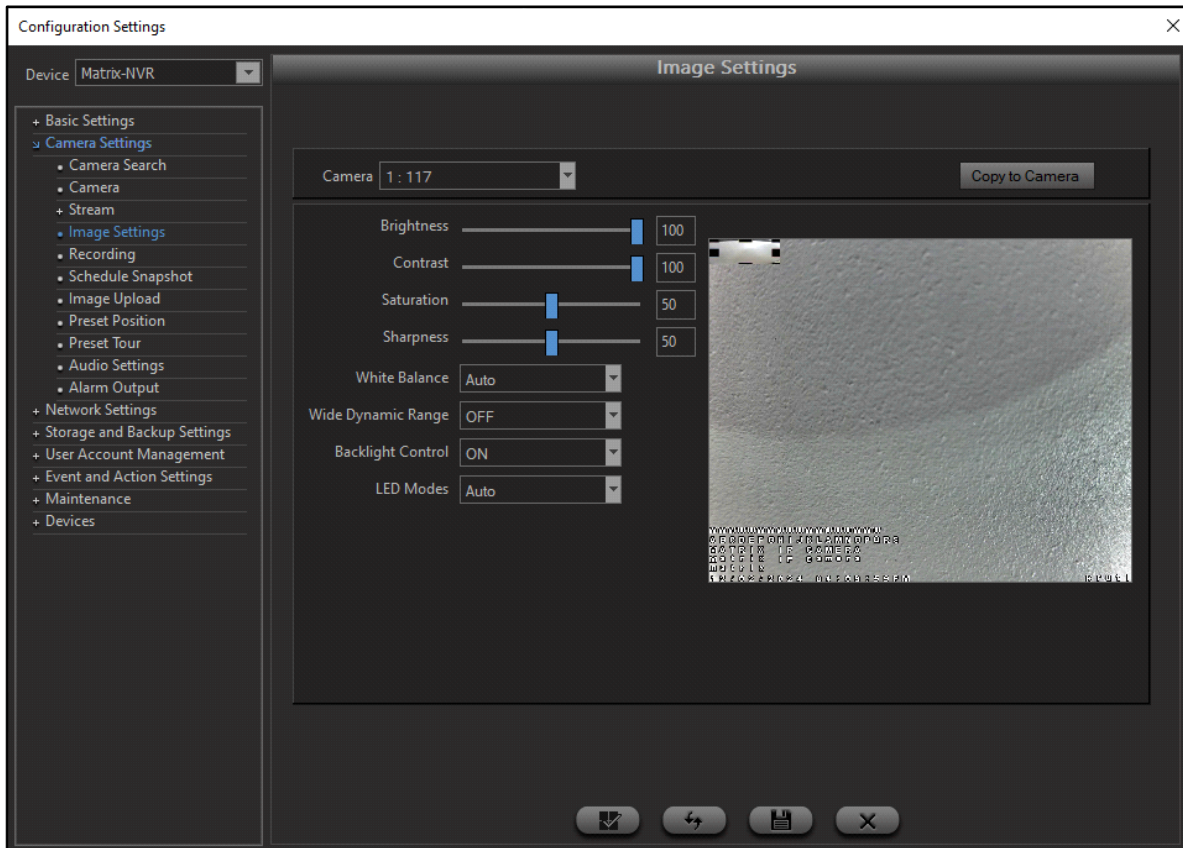

- **Camera:** Select the Camera number from the drop-down list for which you want to view and edit the image settings.
- **Brightness:** To configure the overall lightness of the image drag the slider to the desired position or enter the desired value in the adjoining text-box. Valid Range: 0 - 100.
- **Contrast:** To configure the difference in color and light between objects or regions drag the slider to the desired position or enter the desired value in the adjoining text-box. Valid Range: 0 - 100.
- **Saturation:** To configure the colorfulness of the image color drag the slider to the desired position or enter the desired value in the adjoining text-box. Valid Range: 0 - 100.
- **Sharpness:** To configure the details of the image by sharpening the edges in the image drag the slider to the desired position or enter the desired value in the adjoining text-box. Valid Range: 0 - 100.
- **White Balance:** To adjust the color temperature according to the environment select the desired mode from the drop-down list — **Auto** or **Manual**.
- **Wide Dynamic Range:** To adjust the dark and bright regions within the same image select the desired option from the drop-down list — **Off** or **On**.
- **WDR Strength:** This will only be displayed when **Wide Dynamic Range** is selected as **On**. To control dynamic range of brightness and darkness present in the scene to provide better view drag the slider to the desired position or type value in the adjoining text-box. Valid Range: 1 - 100.
- **Backlight Control:** This will only be displayed when **Wide Dynamic Range** is selected as **Off**. To control the backlight of the image select the desired mode from the drop-down list — **Off** or **On**.

- **D-WDR Strength:** This will be displayed when **Wide Dynamic Range** is selected as **Off** and **Backlight Control** is selected as **On**.

To control dynamic range of brightness and darkness present in the scene to provide better view adjust the slider or type value in the adjoining text-box. Valid Range: 1 - 100.

- **LED Modes:** The function of the LED is to adjust the amount of light reaching the light sensor defined for the night mode. If the light reduces the LED turns on and when it reaches the set value it turns off. Select the desired option — **Auto**, **Always ON** or **Always OFF**. Default value is Auto.

To configure the PAN, Tilt and/or Zoom settings of the camera, refer to “[Preset Position](#)”.

Click **Save** to save all the Image Settings. The preview of the image is visible as per the settings done in the same window.



Preview will be visible only in the Device Client.

Click **Cancel** to abort and exit.

Copy to Camera: You can copy the images settings of a camera to other cameras. To do so, click the respective **Copy to Camera** button.

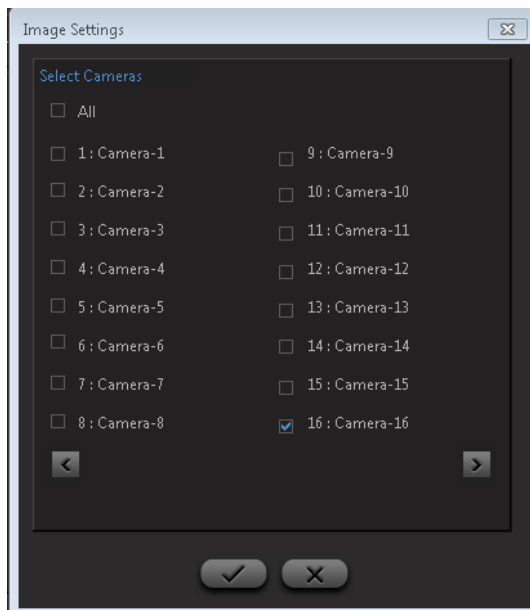

- The **Copy to Camera** window opens.
- Select the check boxes of the desired cameras or select the **All** check box to copy it across all the cameras.
- Click **OK** to copy all the Settings to other cameras or click **Cancel** to abort and exit.

Recording/Adaptive Recording Settings

The Recording/Adaptive Recording changes are applicable for NVRX/NVRX P2 series only.

For other series refer to “[Recording Settings](#)” and “[Adaptive Recording](#)”.

This option enables the user to set the recording parameters for Manual, Alarm, COSEC, Scheduled based as well as Adaptive recording.

Adaptive Recording enables to dynamically allocate the bandwidth using configurable frame rates based on particular needs to optimize the storage.

Click on the **Device Configuration** option from the left pane of the Device Client page. The Device Configuration Settings window appears.

Click **Camera Settings**. Click **Recording**. The Recording page appears.

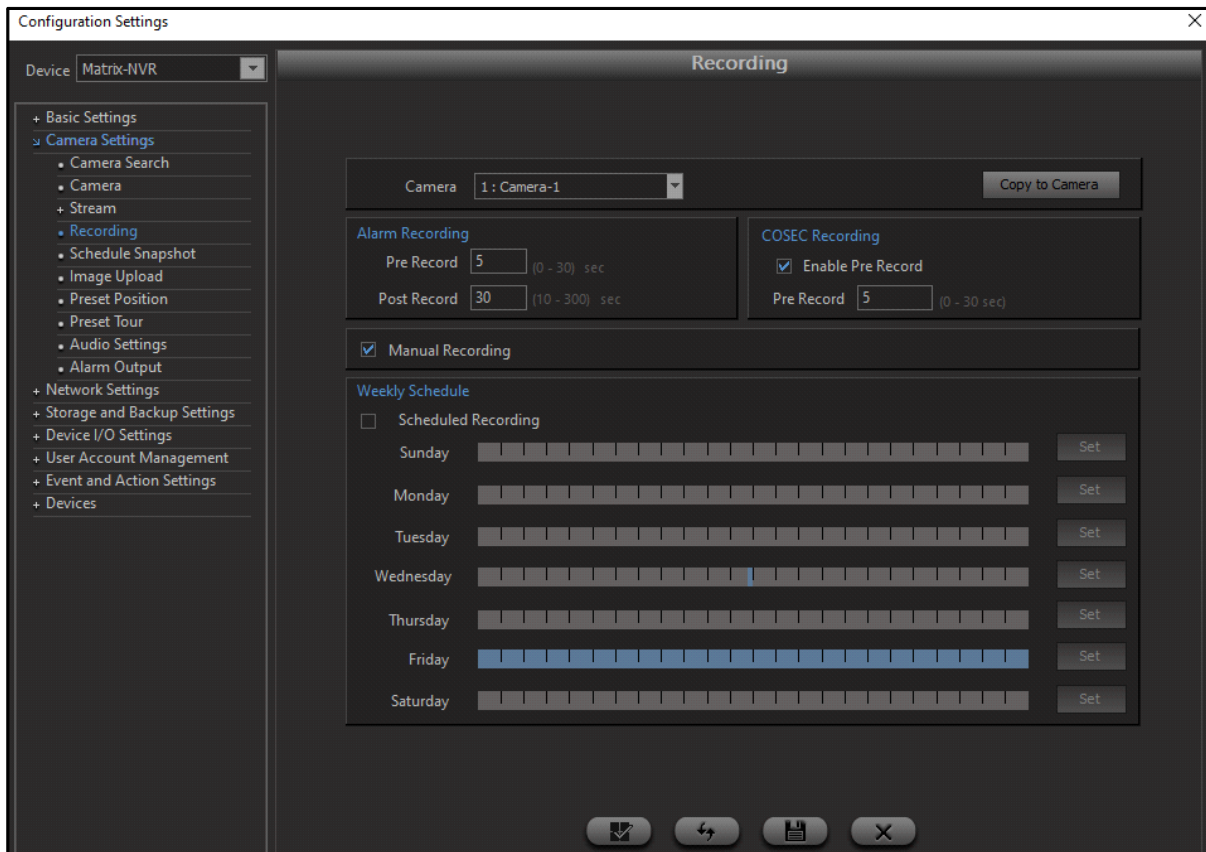

Select the desired **Camera** from the drop-down list.

Configure the parameters of Alarm, COSEC, Manual, Scheduled Recording as well as Adaptive Recording as described below:

Alarm Recording

Pre-Record: Set the time in seconds for pre-alarm event recordings before the actual recording begins on an alarm event. Default pre-recording time is 5 seconds and the configurable range is from 0-15 second.

Post-Record: Set the time in seconds for post-alarm event recordings for the specified channel. Specify the duration in seconds as per the site requirements. The configurable range is from 10-300 second.

COSEC Recording



COSEC Recording is not supported for 2MP and 5MP Ruggedized cameras.

Enable Pre-Record: Select the check box to enable pre-recording in COSEC Recording.

Pre-Record: Set the time in seconds for pre-event recording before the actual recording begins on a COSEC event. Default pre-recording time is 5 seconds and the configurable range is from 0-15 second.

Manual Recording

Select the check box to enable the manual recording for the selected camera. If disabled, manual recording will not be allowed.

Scheduled Recording

If you want to set Scheduled Recording for the camera, select the **Scheduled Recording** check box.

You can set the schedule for each day of the week. To do so,

- Under **Weekly Schedule**, select the day for which you wish to set a schedule and click the corresponding **Set** button. For example, if you click the Set button for Sunday.
- The **Scheduled Recording For Sunday** window opens.

Time Period	Adaptive	Start Time	End Time
1	<input type="checkbox"/>	00 00	00 00
2	<input type="checkbox"/>	00 00	00 00
3	<input type="checkbox"/>	00 00	00 00
4	<input type="checkbox"/>	00 00	00 00
5	<input type="checkbox"/>	00 00	00 00
6	<input type="checkbox"/>	00 00	00 00

Copy To	All	Sun	Mon	Tue	Wed	Thu	Fri	Sat
	<input type="checkbox"/>	<input checked="" type="checkbox"/>	<input type="checkbox"/>	<input type="checkbox"/>	<input type="checkbox"/>	<input type="checkbox"/>	<input type="checkbox"/>	<input type="checkbox"/>

- The Scheduled Recording can be set for the Entire Day or for different time slots during the day.

Scheduled Recording for Entire Day

- To schedule the recording for the entire day, select the **Entire Day** check box.

- If you wish to set Adaptive Recording during the entire day, select the **Adaptive** check box.

Scheduled Recording for Time Period 1 to 6 (different time slots during the day)

- To set the recording for different time slots, set the desired **Start Time** and **End Time** for each time slot.
- If you wish to set Adaptive Recording for the time slot, select the **Adaptive** check box.
- You can copy the settings done for a day to the other days of the week. Select the check boxes of the desired days or click **All** to apply it to the entire week.
- Click **Save** to save the changes. You return to the Recording window.

You can copy the recording settings done for a Camera across multiple cameras, to do so, click **Copy to Camera:**

The Schedule Recording pop up appears.

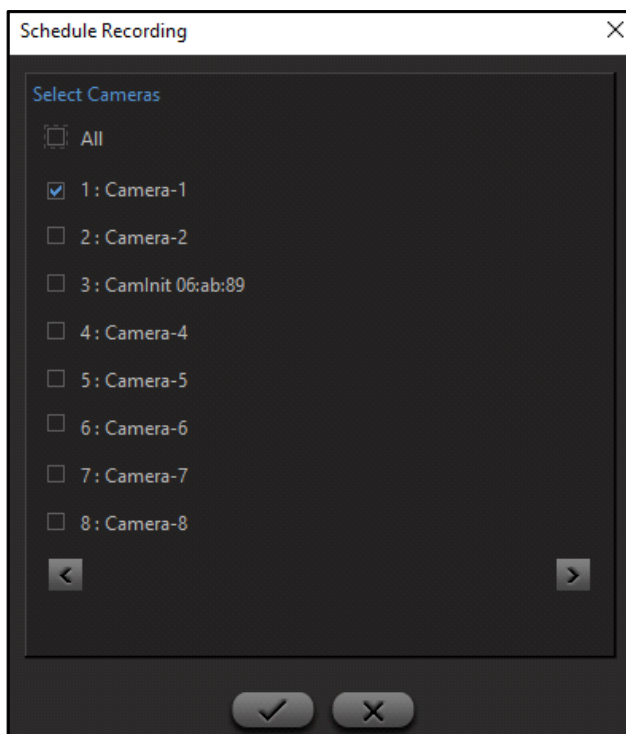

Select the check boxes against the respective camera or select the **All** check box to copy it across all the cameras.

Click **Save** once done.

Recording Settings

This option enables the user to set the recording parameters for Manual, Alarm, COSEC and Scheduled based recording. Click on the Configuration option from the left pane of the Device Client page. The Configuration Settings page appears. Select the Recording option. The Scheduled recording page appears as shown below:

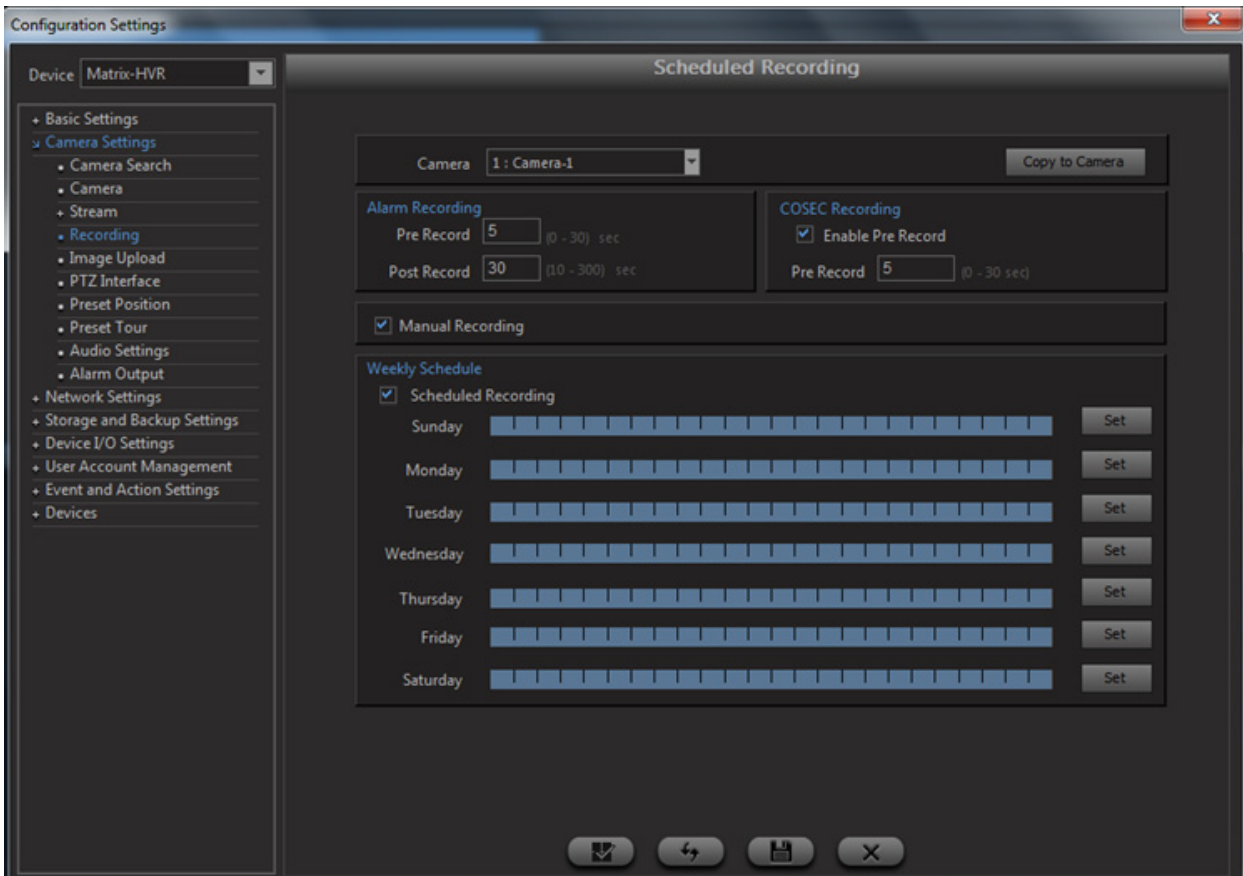

Select the **Camera Number** by scrolling the up-down arrows. Then configure the parameters of Alarm, COSEC, Manual or Scheduled Recording as described below:

Alarm Recording

Pre-Record: Set the time in seconds for pre-alarm event recordings before the actual recording begins on an alarm event. Default pre-recording time is 5 seconds and the configurable range is from 0-15 second.

Post-Record: Set the time in seconds for post-alarm event recordings for the specified channel. Specify the duration in seconds as per the site requirements. The configurable range is from 10-300 second.

COSEC Recording



COSEC Recording is not supported for 2MP and 5MP Ruggedized cameras with firmware IPCamera_S05_FirmwareV03R01 and later.

Enable Pre-Record: Check the box to enable pre-recording in COSEC recording.

Pre-Record: Set the time in seconds for pre-event recording before the actual recording begins on a COSEC event. Default pre-recording time is 5 seconds and the configurable range is from 0-15 second.

Manual Recording

Check the box to enable the manual recording for the selected camera. If disabled, manual recording shall not be allowed.

Scheduled Recording

Check the box to enable the scheduled recording for the selected camera.

Click on the **Set** button in the **Weekly Schedule** section against the day for which the schedule is to be set. The weekly schedule window appears as shown.

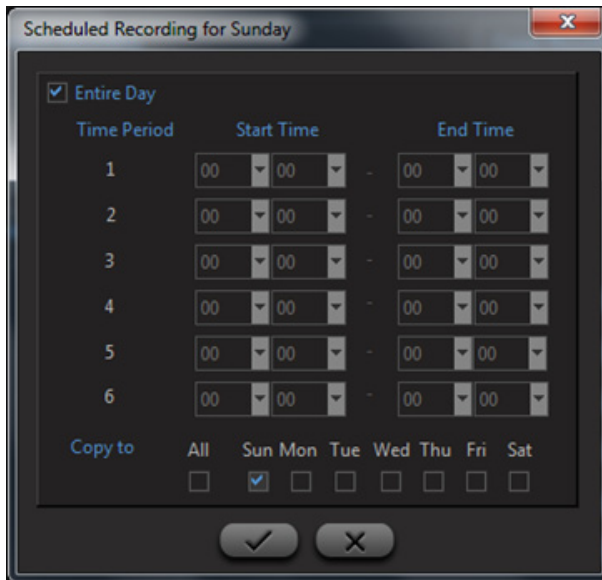

Specify the time periods for the scheduled recording by clicking on the drop-down list.

In order to copy the schedule to multiple days, check the boxes of the respective weekdays. Check the **All** box to copy the schedule to all the days of the week.

Click on **OK** once done. The system returns the user to the **Schedule Recording Settings** page.

Copy to Cameras: The defined schedule can be copied across multiple channels. To Copy the Recording settings from one camera channel to other, click on Copy to Cameras button. The camera selection page appears as shown below:

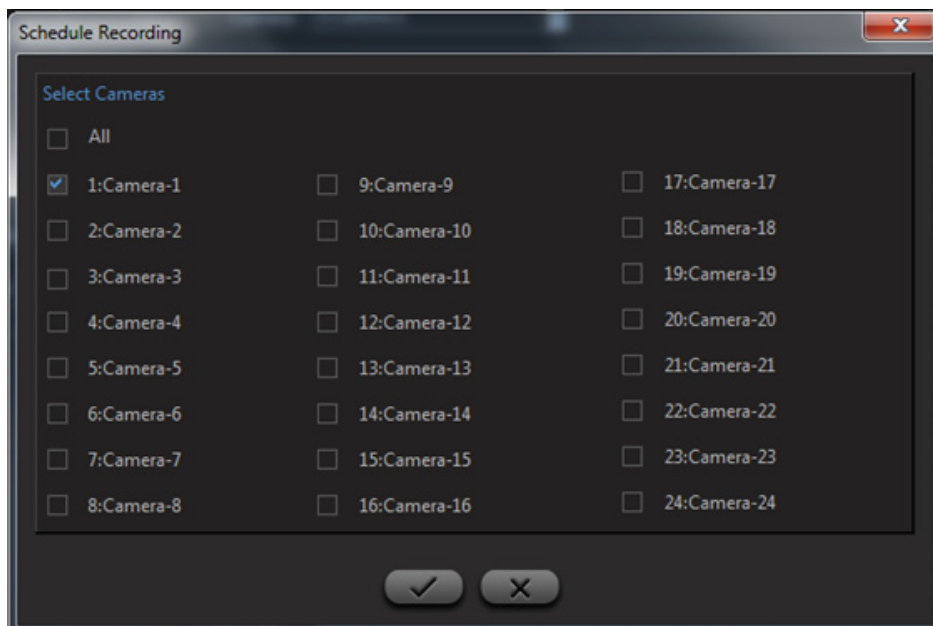

Check the boxes against the respective channels or check the **Select All** box to copy it across all the channels.

Click on **Save** once done.

Adaptive Recording

Adaptive Recording enables to dynamically allocate the bandwidth using configurable frame rates based on particular needs to optimize the storage.

Click on the Configuration option from the left pane of the Device Client page. The Configuration Settings page appears. Select the **Adaptive Recording** option under **Camera Settings**.

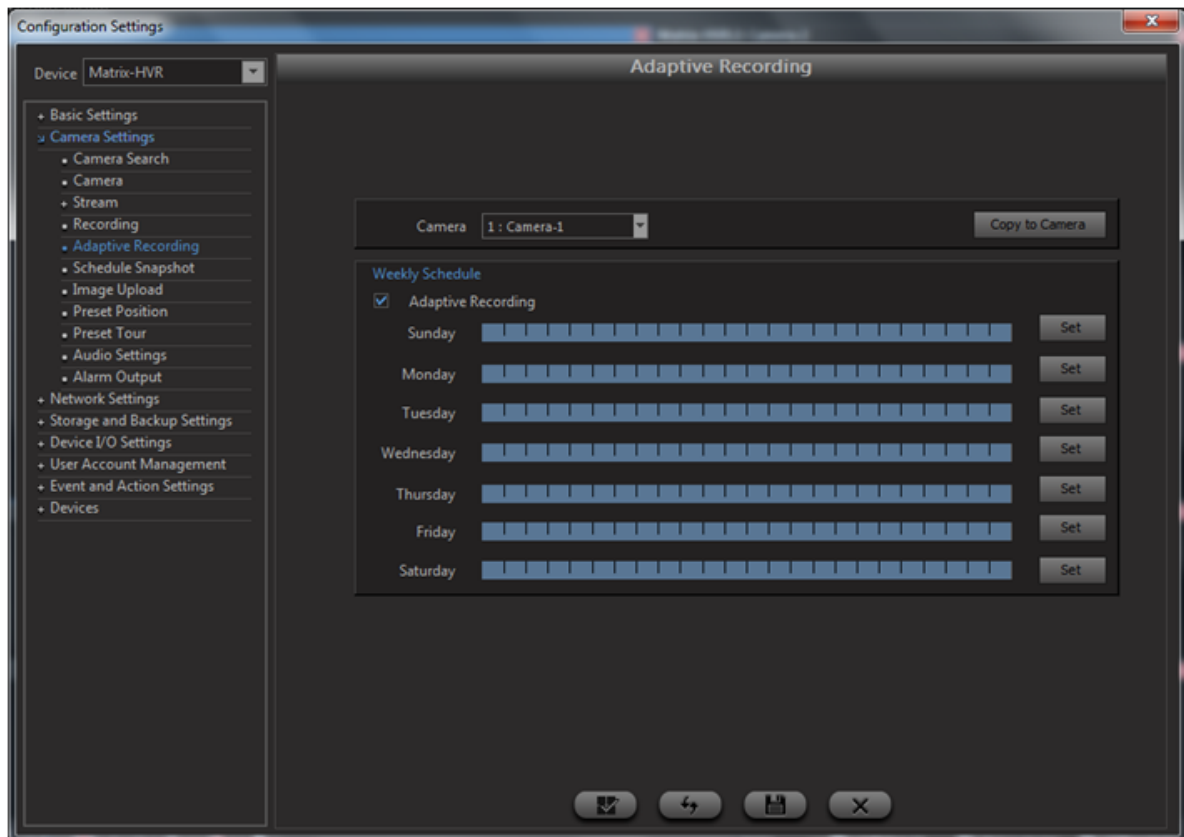

Select the **Camera** from the drop-down list for which Adaptive Recording is to be configured. Then configure the parameters as described below:

Enable the **Adaptive Recording** feature to allow scheduling the days for recording. This will start the device to record only I- frames in normal recording but if any alarm event (Motion, View Tamper, Sensor trigger) occurs then device will record all frames provided Alarm Recording is active in that particular schedule from **Event and Action Settings** page.

Once done, the user can set different time periods for different days. Click **Set** button against the day for which the schedule is to be set and the following screen appears.

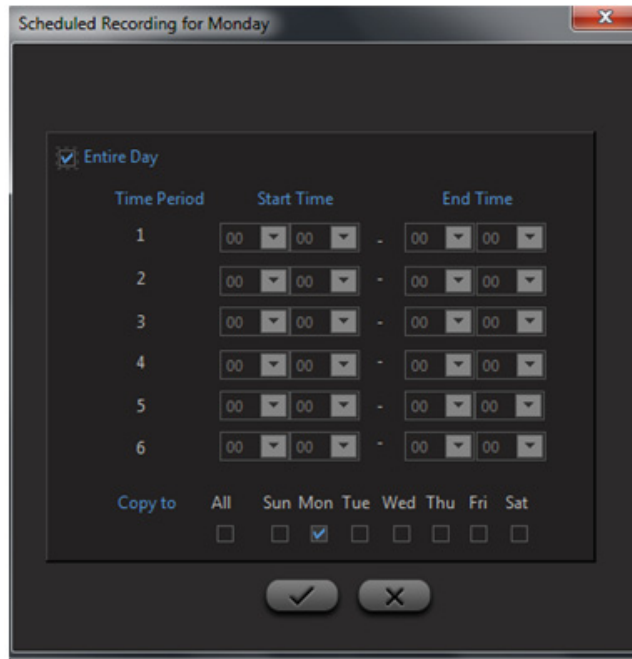

Entire Day: Select the check box for configuring schedule for the entire day.

Time Period: The Adaptive Recording can also be configured for a particular time period by specifying the time interval in hh:mm format in **Start Time** and **End Time** fields.

Copy To: The Scheduled Recording for one day can be copied to other days or all days by clicking the respective boxes. Select the **All** check box to copy the schedule to all the days of the week.

Click on **OK** button and the system returns the user to the **Adaptive Recording** page.

Copy to Cameras: The defined schedule can be copied across multiple channels. To Copy the Adaptive Recording settings from one camera channel to other, click on **Copy to Cameras** button. The camera selection page appears as shown below:

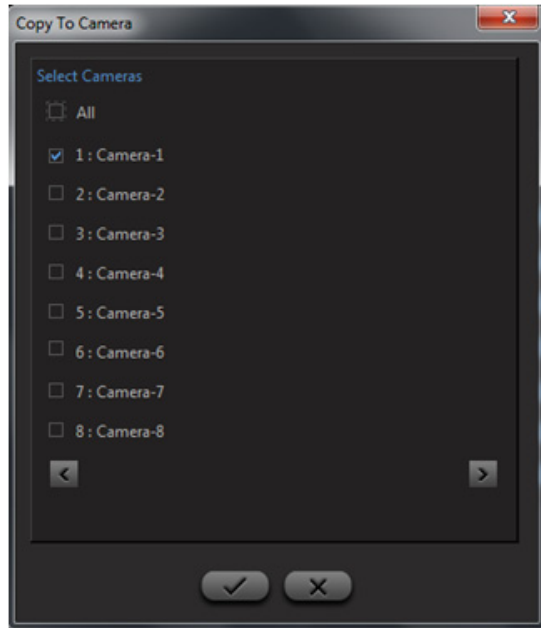

Select the boxes against the respective channels or select the **All** checkbox to copy it across all the channels.

Click on **Save** button and the system returns the user to the **Adaptive Recording** page. From this page one can click the **Default** button to set the value of all configurations to its default values or click **Save** to save the changes.

Schedule Snapshot

This option enables the user to schedule the snapshot instead of recording for a particular location at specified time. Click on the Configuration option from the left pane of the Device Client page. The Configuration Settings page appears. Select the Schedule Snapshot option.

Select the **Camera Number** from the drop-down list.

The SATATYA device has the functionality to upload the camera snapshot to an Email server, FTP server or Network drive.

Select the option for **Upload To** from the drop-down list. The options available are:

- Email Server
- FTP Server 1
- FTP Server 2
- Network Drive 1
- Network Drive 2

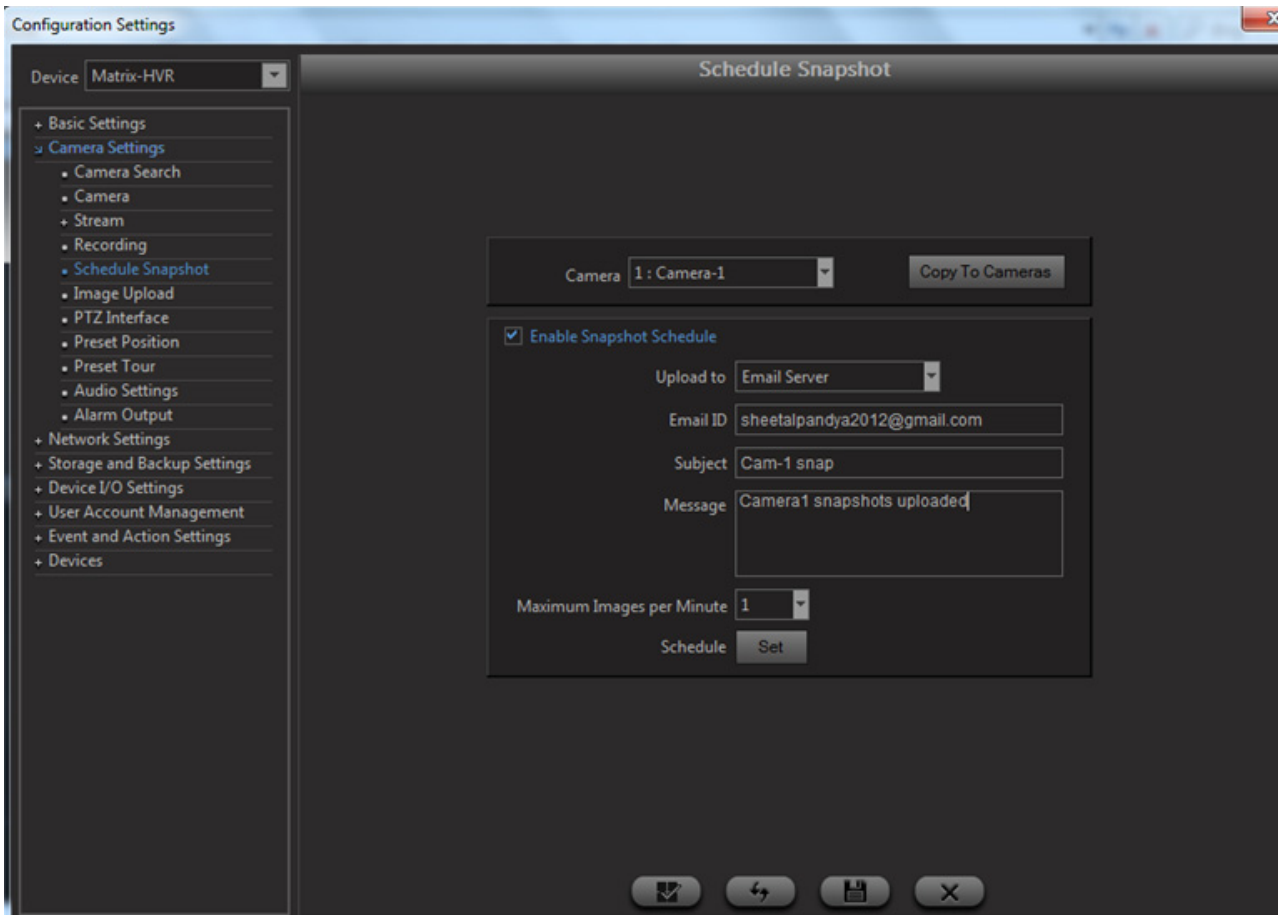

In the event of selecting the Email Server, specify the **Email address** to which the email with the image is to be sent. Also specify the **Subject** and the **Message** to be included in the email.

Select the number of images to be uploaded per minute from the **Max. Images Per Minute** drop-down list.

Click on **Set** button to set the Snapshot Schedule.

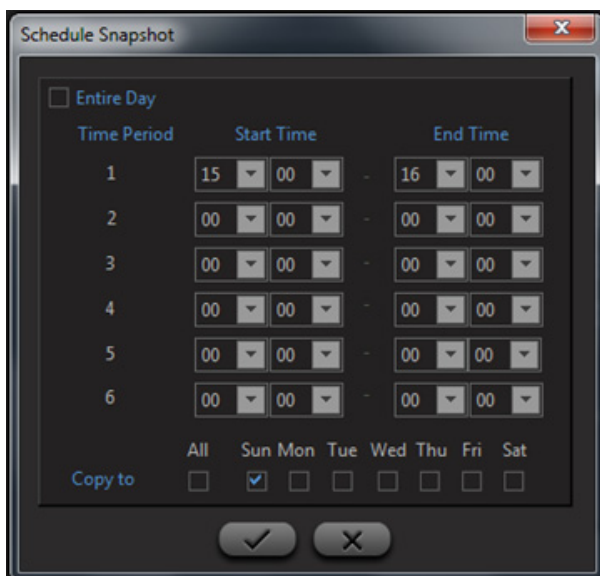

Specify the time periods for the scheduled snapshot by selecting the Start time and End time. Also you can select the Entire Day.

In order to copy the schedule to multiple days, check the boxes of the respective weekdays. Check the **All** box to copy the schedule to all the days of the week.

Click on **OK** once done.

Click on **Save** to save the changes.

Image Upload Settings

This option enables the user to set the image upload parameters for configured events. Click on the Configuration option from the left pane of the Device Client page. The Configuration Settings page appears. Select the Image Upload option. The Image Upload Settings page appears as shown below:

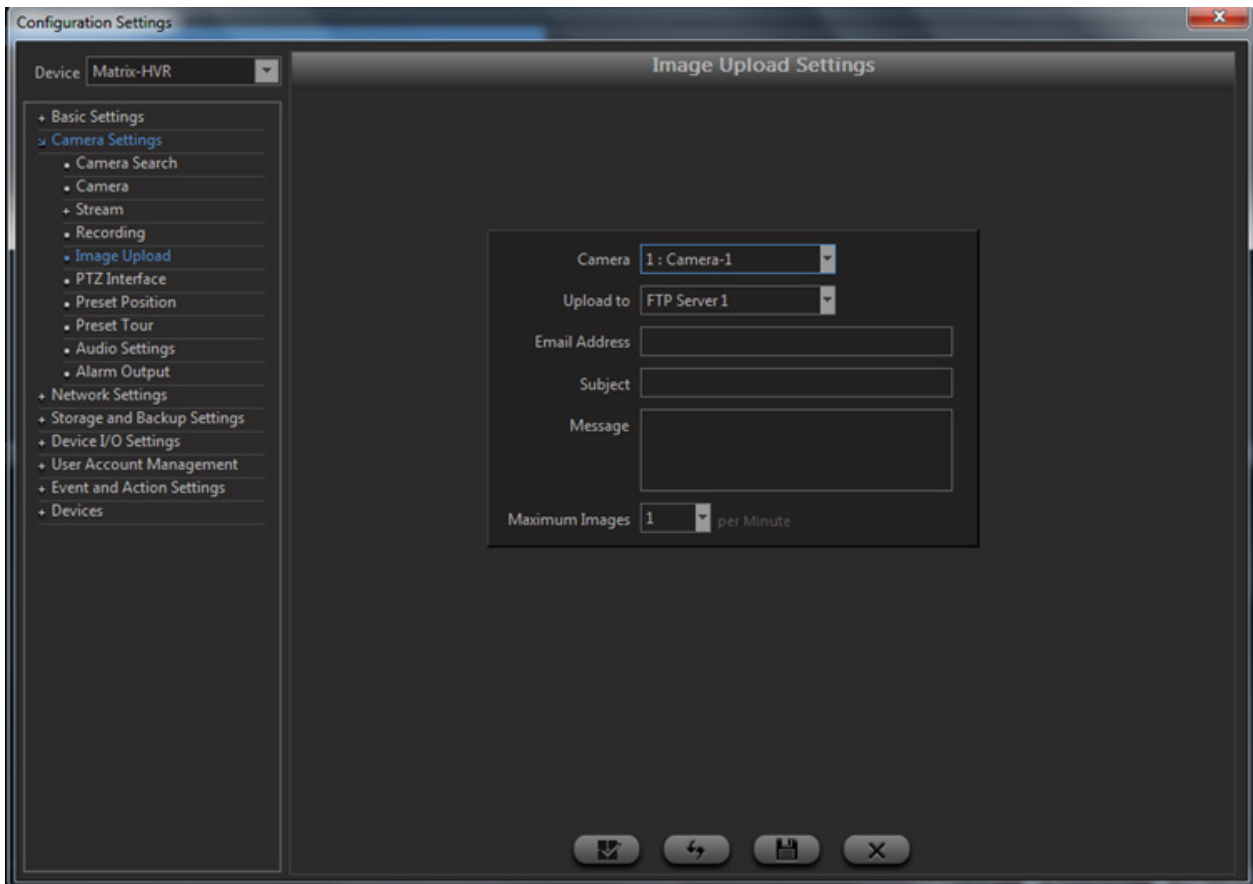

Select the **Camera Number** from the drop-down list.

The SATATYA device has the functionality to upload the image to an FTP server, send the image in an email or upload to a network drive. Select the appropriate option for **Upload To** from the drop-down list. The options available are:

- Email Server
- FTP Server 1
- FTP Server 2
- Network Drive 1
- Network Drive 2

In the event of selecting the email server, specify the **email address** to which the email with the image is to be sent. Also specify the **Subject** and the **Message** to be included in the email.

Select the number of images to be uploaded per minute from the **Max. Images Per Minute** drop-down list.

Click on **Save** to save the changes.

PTZ Interface

To control the PTZ functions of the camera, connect the RS485 port of the PTZ camera to the RS-485 port on the SATATYA Device.

Refer the camera manual for the DIP switch settings on the camera to set the RS 485 address as well as the protocol. Select the **PTZ Interface** option under the **Camera Settings**. The following window appears:

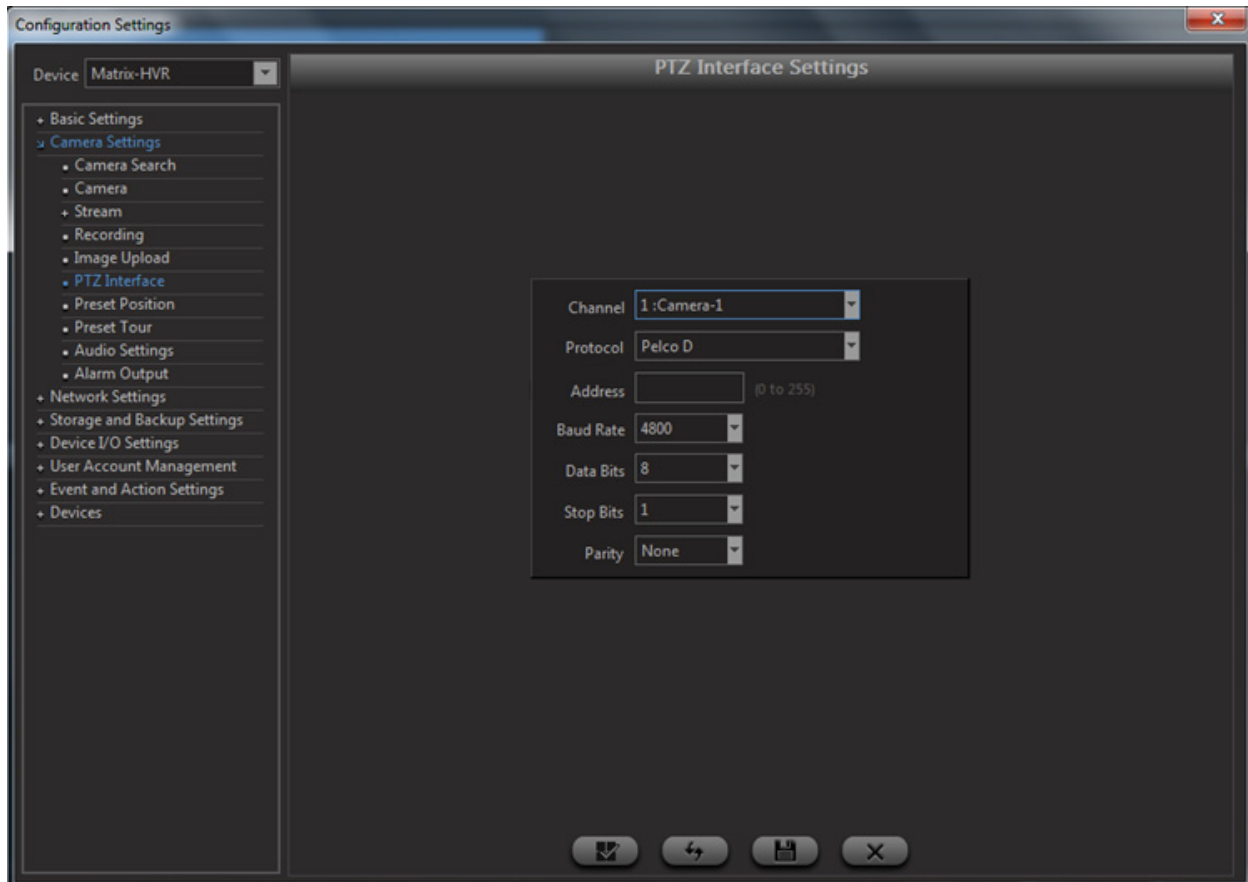

Select the **Channel** number which is connected to the PTZ camera.

Select or set the **protocol** type of the camera so that it is the same as the one installed on the site. The options available are:

- PELCO D
- PELCO P
- NONE

Specify the **RS-485 address** of the camera using the virtual keyboard. The address is as set using the dip switch on the camera.

The **Baud rate** to be specified is dependent on the camera and is to be set as per the site requirements.

Similarly, specify the **Data Bits**, **Stop Bits** and the **Parity** information as per the camera requirements.

Click on **Save** once done.

Preset Position

If a camera uses a Pan/Tilt/Zoom (PTZ) device, it is possible to define which preset position the device will move to when an event is triggered. Multiple preset positions for each camera can be configured using this functionality. The SATATYA device (HVR) can save up to 30 preset positions per channel. However, 40 Preset Positions per channel are supported in NVRX/NVRX P2 series.

Presets can be set to move a PTZ camera to a desired preset location at the click of a button. This option is used to create as well as modify preset positions.

Click on the **Configuration** option from the left pane of the Device Client page. The **Configuration Settings** page appears. Select the **Preset Position** option under **Camera Settings**. The Preset Position Settings page appears as shown below.

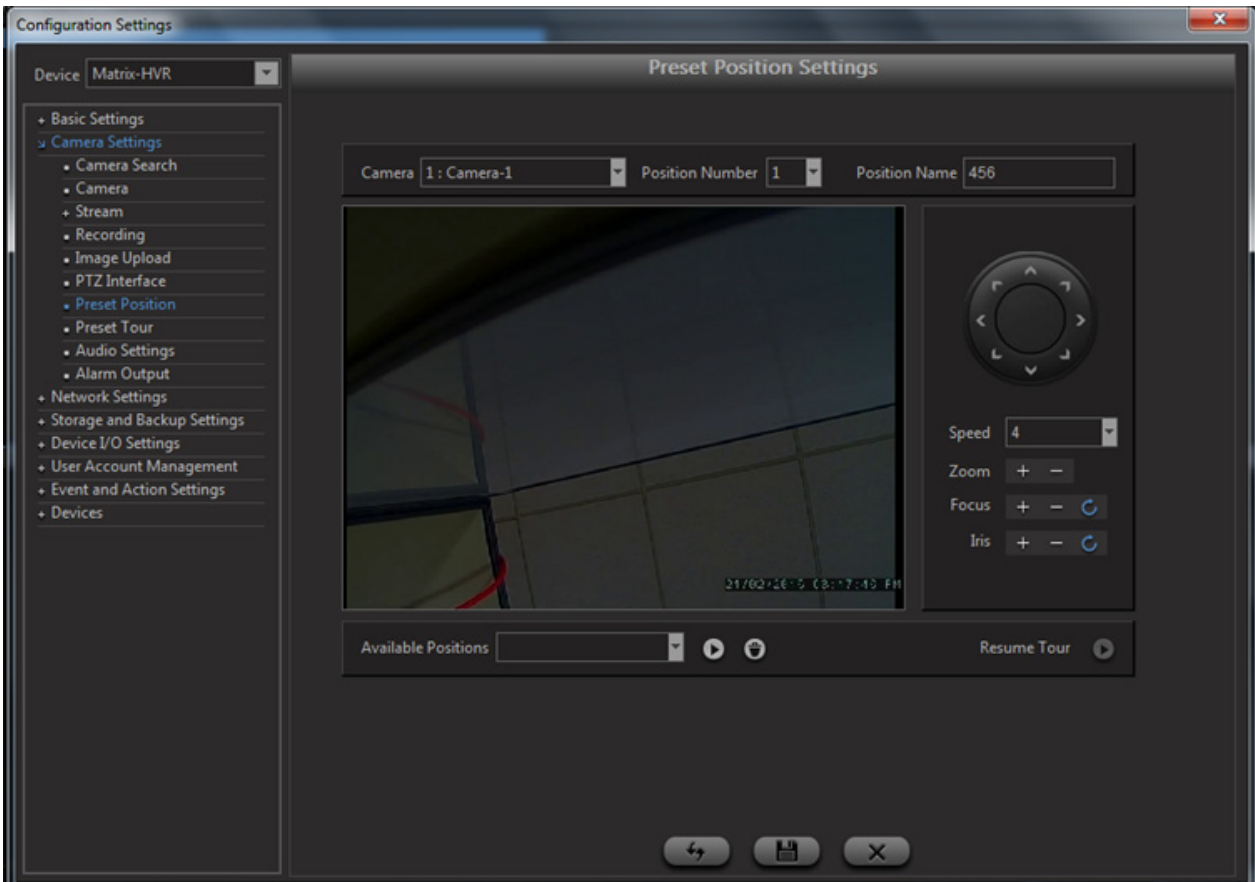

Select the channel of the PTZ **Camera** from the drop-down list. The system will display the 1x1 monitoring window of the selected channel on the page as shown.

Select the **Position Number** from the drop-down list.

Specify a user friendly **Name** for the position. Use the Preset Position arrow keys to move the camera to the required position.

Click on **Save** button when done.

User can now select a new position no. and configure the parameters for another preset position for the same camera.

To edit an existing preset position, select the configured position in the Position field. Click on the **Go** button. The camera will move to the preset position as already configured. Use the Preset Position arrow keys to move the camera to a new position and click on the **Save** button.

Click on **Delete** button to delete a configured preset position. The PTZ tour can be started by clicking **Resume Tour**.

Preset Tour

The Preset Tour functionality enables the administrator to create a PTZ tour with up to 20 preset positions. In order to access this option, click on the **Configuration** option from the left pane of the device client page. Select the **Preset Tour** option under **Camera Settings**. The Preset Tour Settings page appears as shown below.

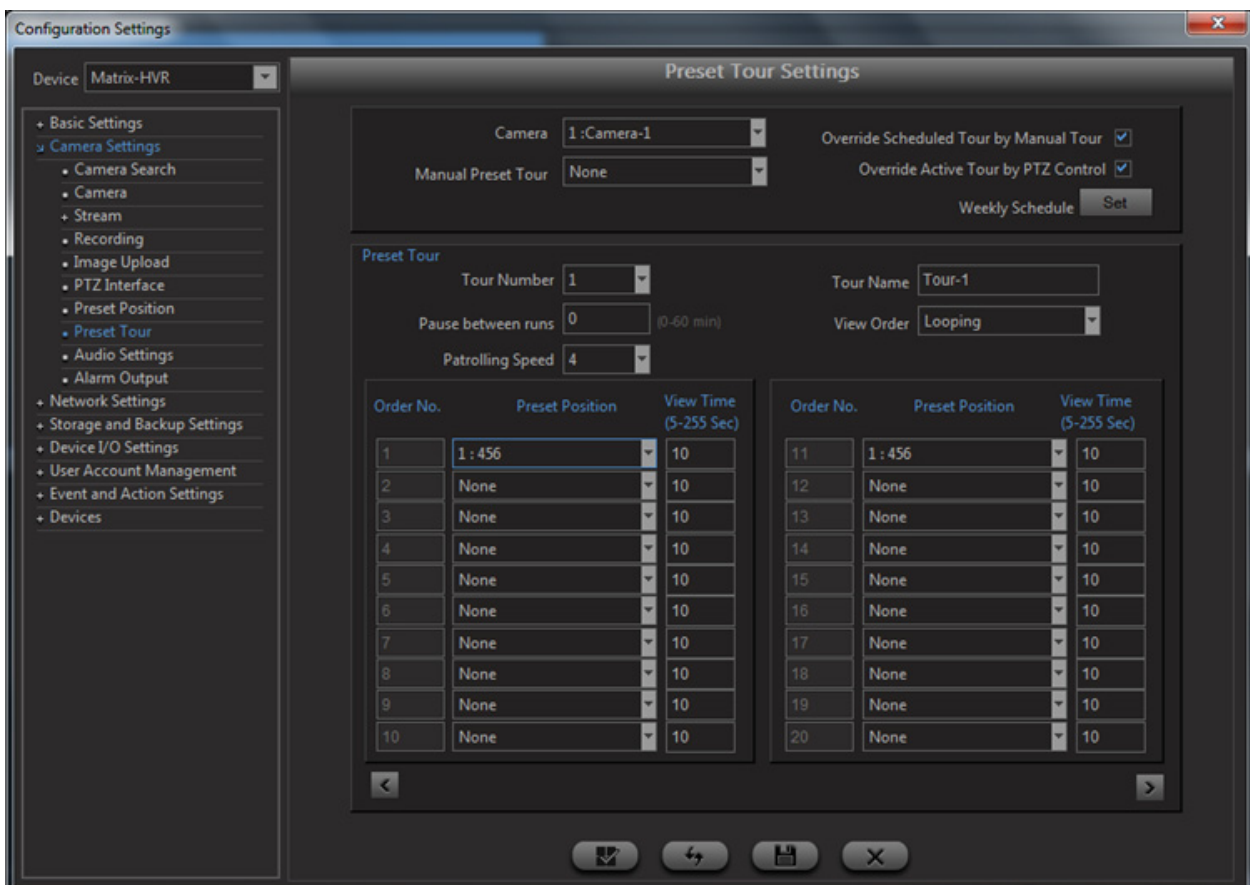

Camera: Select the Camera Channel from the drop-down list where the PTZ Camera is connected.

Override Scheduled Tour by Manual Tour: Check the box to Enable the user to Start Manual Tour from the monitoring window by clicking **PTZ**  button.

Manual Preset Tour: Select the Tour from the drop-down list which is to be manually operated from the **PTZ**  button of monitoring window. Before Selection of the Tour for Manual Operation, ensure that the Tour is configured.

Override Active Tour by PTZ Control: Check the box to Enable control of PTZ camera when PTZ tour is going on. While doing PTZ control if tour is active then the active tour will get paused and resume when clicked on resume button.

Select the Camera Channel on the monitoring window. Click the **PTZ**  button. The PTZ Control window appears as shown below. Click on Manual Tour button as shown below:

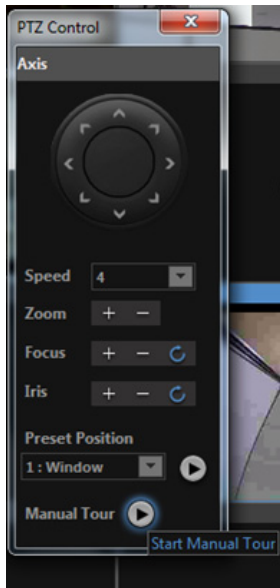

Weekly Schedule: Click on the **Set** button to define the Weekly Schedule for the PTZ Tour. The page appears as shown below:

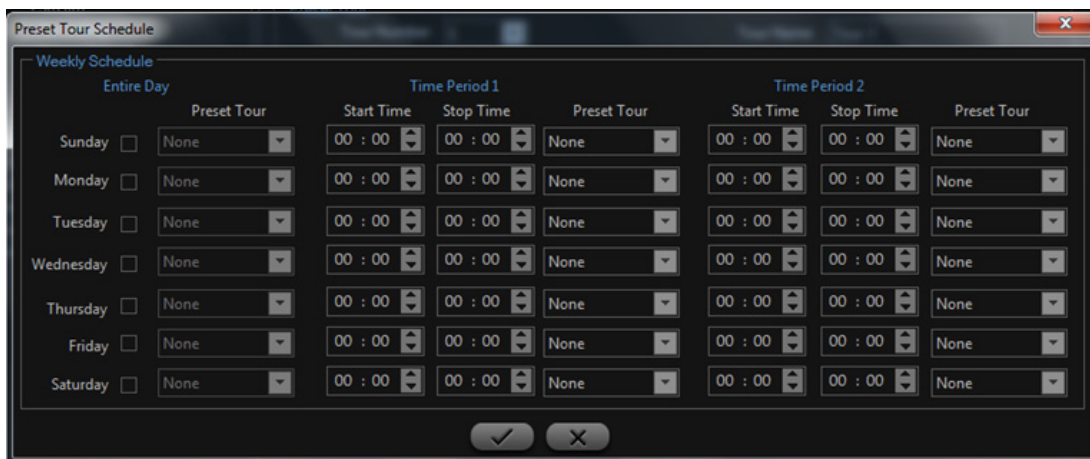

Set the **Start Time** and the **Stop Time** for the PTZ Tour using the up/down slider buttons. The system allows the administrator to define up to two time periods for a particular day as shown in the above figure.

Click on **OK** once done. The system returns the user to the PTZ Tour Settings page as shown earlier.

Preset Tour

This Section enables the administrator to create a PTZ tour with up to 20 preset positions as defined in [“Preset Position”](#) section. The administrator can set up to a maximum of 5 tours per channel.

Tour Number: Select the Tour Number from the drop-down list.

Tour name: Specify a user friendly Tour name.

Pause Between Runs: Specify the time in seconds between successive runs of the Tour.

View Order: Select the Positioning Order from the drop-down list. This defines the order in which the camera moves through the preset positions.

- **Looping:** The PTZ camera moves through the preset positions in sequential order from first to the last. On reaching the last position, the camera loops through and starts again from the first preset position.
- **Zigzag:** The PTZ camera moves up and down through the defined preset positions i.e. from first to last followed by last to first preset position.
- **Random:** The PTZ camera moves through the preset positions in random order.

Now select the preset positions for the tour from the drop-down list in the order as required. The **View time** defines the dwell time of the camera in the specified preset position.

Click on **Save** once done.

Audio Settings

In order to access this option, Click on the **Configuration** option from the left pane of the device client page. Select the **Audio Settings** option under **Camera Settings**. The Audio Settings page appears as shown below.

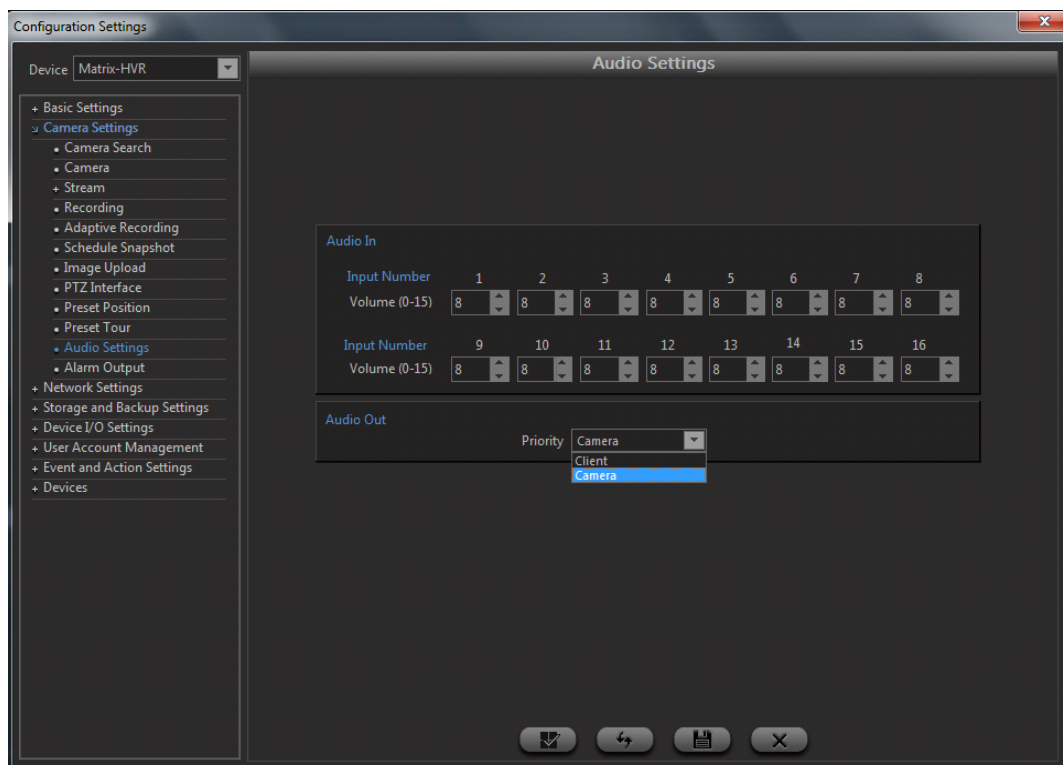

Audio IN: This functionality enables the user to set the **Volume** of the Audio Input Channel of device.

Specify the Volume for each of the audio channels by scrolling the arrow buttons to the required value. The range available is from 0 to 15.

Audio Out: Select the option as Client or Camera to whom the Audio out priority is to be given.



Audio Out Priority is considered when “Speak to Device” action is performed.

NVRs and HVR0408 variants Audio Settings page, only **Audio Out** settings is available as shown below:

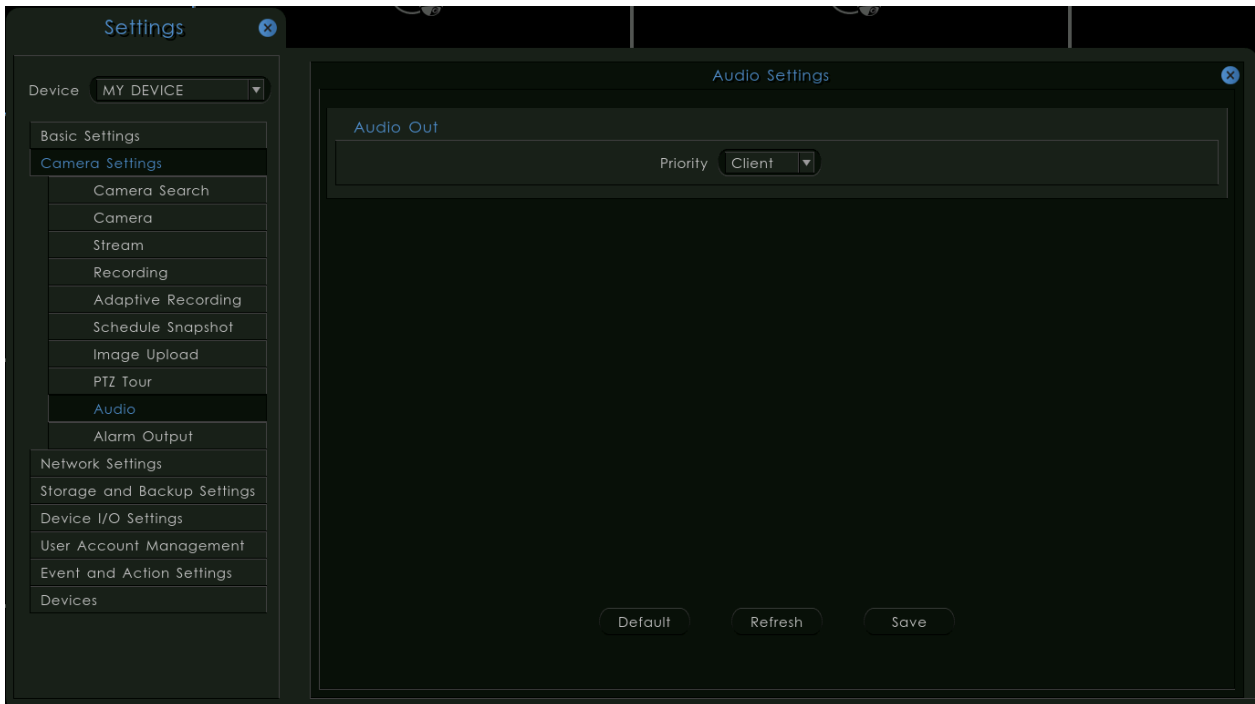

For details on Two Way Audio feature, See [“Two Way Audio” on page 181](#).

Click on **Save** once done.

Alarm Output

The Matrix SATATYA device has the functionality to activate alarm outputs on the cameras based on the occurrence of certain configured events. When the output relay is enabled on this page it will then be available to all events, which in turn can have the relay enabled or disabled, independently of each other.

In order to access this option, click on the Configuration option in the left pane of the device client page. The following page appears. Select the Alarm Output option under Camera Settings as shown. The Camera Alarm Output Settings page appears.

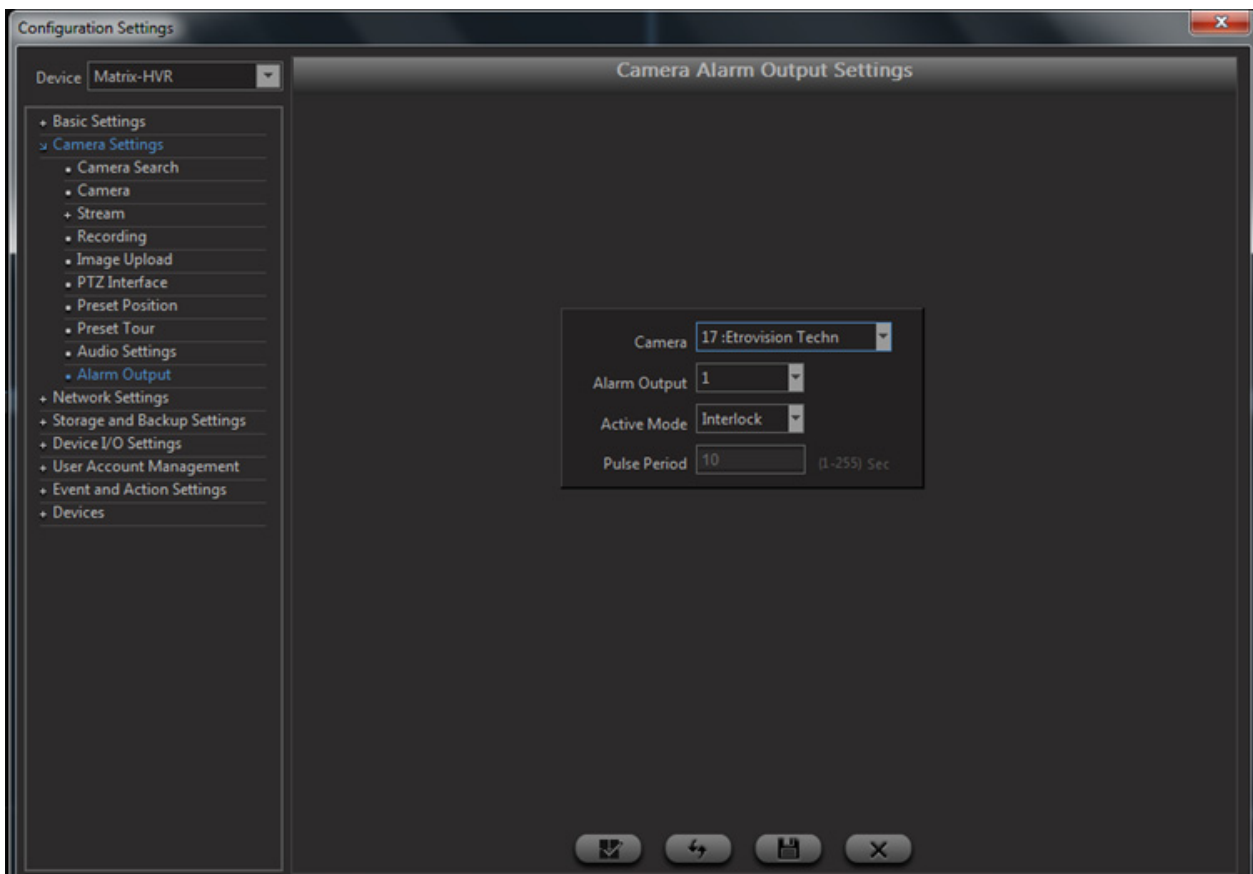

Select the Camera from the drop-down list.

Alarm Output: Select the output from the drop-down list. The number of outputs appearing in the drop-down list is dependent on the selected camera model.

Active Mode: This field will store the mode based on which the selected alarm output will remain activated, once triggered by an event. The active modes available are:

- Interlock
- Pulse

If the configured mode is **Interlock**, then the respective output will get activated by an event trigger and will be normalized once that event is normal.

If the configured mode is **Pulse**, then the respective output will get activated by an event trigger and will be normalized after a specified Pulse Period, starting from the time of activation of an event, irrespective of the state of that event.

The SATATYA Device comes with the following configured default IP address settings.

Ethernet Port 1 default settings:

IP Address: 192.168.1.123
Subnet Mask: 255.255.255.0
Gateway Address: 192.168.1.1

Ethernet Port 2 default settings:

IP Address: 192.168.2.2
Subnet Mask: 255.255.255.0
Gateway Address: 192.168.2.1

To know more about the availability of Ethernet ports in various STATATYA Devices, [See “Setting Network Parameters” on page 91.](#)

The following Network settings can be configured:

- “LAN 1”
- “LAN 2”
- “DHCP Server Settings”
- “Broadband Settings”
- “Static Routing”
- “IP Address Filtering”
- “DDNS”
- “Email Client Settings”
- “FTP Client Settings”
- “TCP Server Settings”
- “Media-File Access”
- “SMS Settings”
- “Monitor Client (Not Applicable for NVRX and NVRX P2 series)”
- “P2P”

LAN 1

To configure the Network Settings, click on the **Configuration** option from the left pane of the device client page. Select **Network Settings**. The **LAN1 Settings** Page appears as shown below.

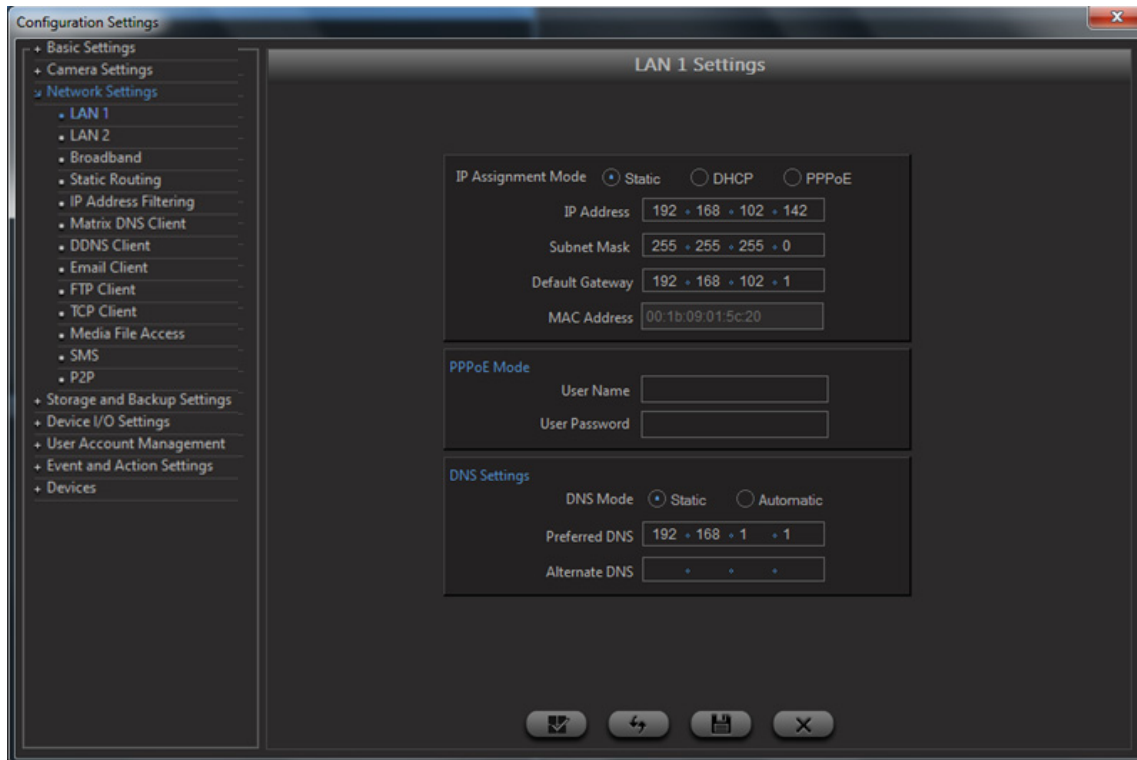

IP Assignment Mode

The NVRX/NVRX P2/HVR has three modes of IP assignment based on which the network settings of the HVR can be configured. The following three modes of IP assignments are available:

Static: On selecting Static mode the administrator can assign

- IP: Static IP address to the HVR based on the availability.
- Subnet Mask: The Subnet Mask for the LAN
- Gateway: The IP Address of the Gateway

DHCP: On selecting the DHCP option, the DHCP server automatically assigns an IP address to the HVR when it comes on the network and thus no physical IP address is to be assigned to the HVR by the administrator.

PPPoE: On selecting the PPPoE mode, the IP Address and the Subnet Mask will be assigned automatically by the PPPoE Server. The User Name and Password will be provided by the network administrator.

- User Name - The user ID for the connection.
- Password - The password for the connection

When you select the User Name and Password field, the Virtual Keypad will appear enabling you to enter alphanumeric characters.

MAC Address: This field displays the MAC address of the HVR's Ethernet port and cannot be edited.

Configuring Domain Name Server

The DNS Settings section enables the administrator to specify the server that normally provides the translation of domain names to IP addresses on your network.

In the event of selecting the DHCP option of IP assignment the user may choose the **Automatic** option for the DNS Server Mode.

In the event of choosing the **Static** option enter the IP address of the primary DNS server. If the server is not able to resolve a domain name immediately, it will then distribute the domain name query to other DNS servers on the network.

Specify the IP address of the secondary DNS server. This is the address of the server normally used to provide the domain name translation if the primary DNS server is unavailable.

Click on **Save** once done.

LAN 2

Now the user can configure the network settings of the LAN2 port. Select **Network Settings** and click on **LAN2**. The LAN2 Settings Page appears as shown below.



The SATATYA HVR is assigned a Static IP for LAN2 Port. The administrator can assign a **Static IP address** to the HVR based on the availability. And specify the **Subnet Mask** and the **Gateway** based on the network settings at the site.

MAC Address: This field displays the MAC address of the HVR's Ethernet port and cannot be edited.

Click on **Save** button to commit the changes.

DHCP Server Settings

DHCP Server is a network server that automatically provides and assigns IP addresses, default gateways and other network parameters to the client devices. NVRX/NVRX P2 series support a DHCP Server. To use the DHCP Server, you must configure the following parameter:

DHCP Server Settings in Local Client

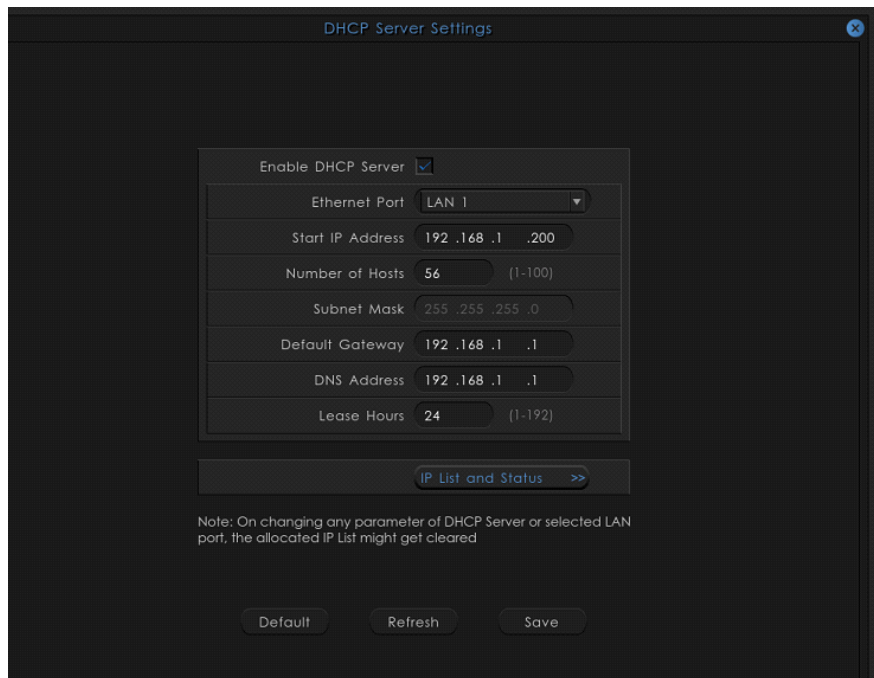

The screenshot displays the 'DHCP Server Settings' window. At the top, the title bar reads 'DHCP Server Settings'. The main content area includes the following fields:

- Enable DHCP Server:** A checked checkbox.
- Ethernet Port:** A dropdown menu set to 'LAN 1'.
- Start IP Address:** A text input field containing '192 .168 .1 .200'.
- Number of Hosts:** A numeric input field set to '56', with a range '(1-100)' indicated to the right.
- Subnet Mask:** A text input field containing '255 .255 .255 .0'.
- Default Gateway:** A text input field containing '192 .168 .1 .1'.
- DNS Address:** A text input field containing '192 .168 .1 .1'.
- Lease Hours:** A numeric input field set to '24', with a range '(1-192)' indicated to the right.

Below these fields is a button labeled 'IP List and Status' with a right-pointing arrow. A note below the button reads: 'Note: On changing any parameter of DHCP Server or selected LAN port, the allocated IP List might get cleared'. At the bottom of the window are three buttons: 'Default', 'Refresh', and 'Save'.

DHCP Server Settings in Device Client

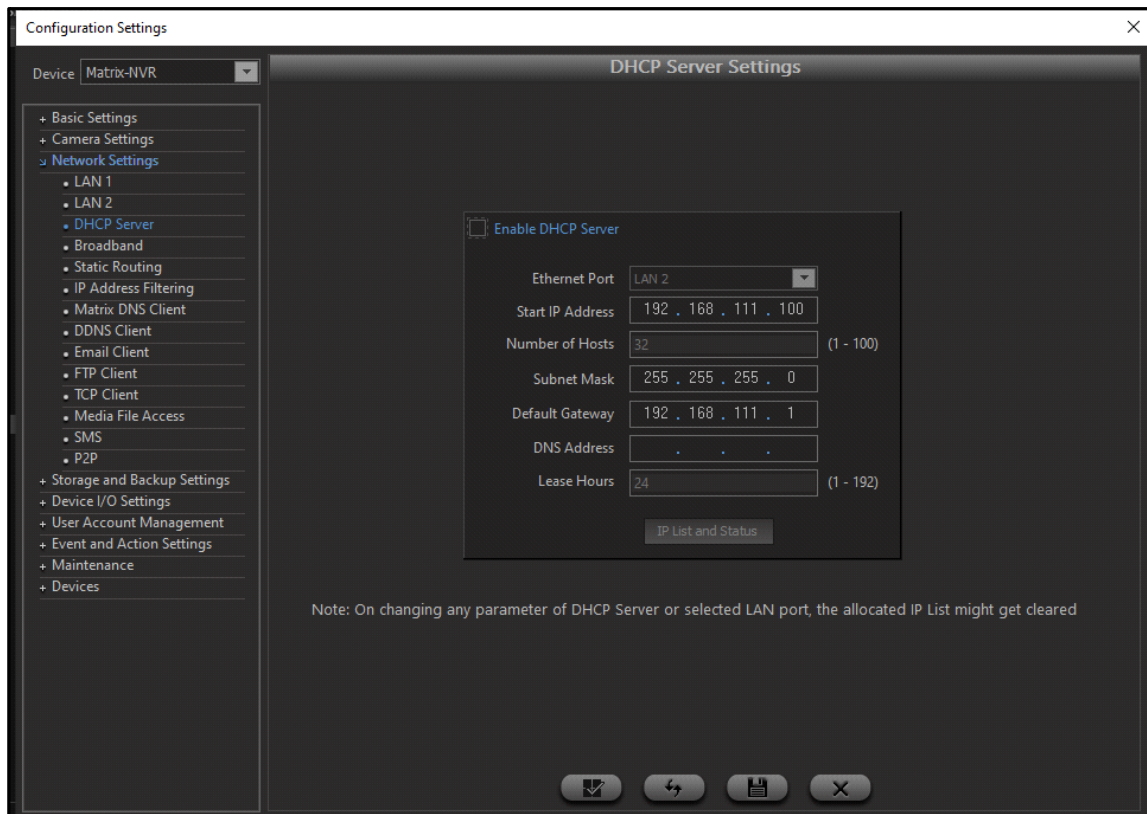

- Select the **Enable DHCP Server** check box.
- Select the desired **Ethernet Port** — LAN 1, LAN 2— which will be used for dynamic assignment of IP Addresses to the DHCP clients (IP cameras).



LAN1 and LAN2, will be displayed if the NVRX/NVRX P2 installed supports two ports.

In LAN 1 Settings if the IP Assignment Mode is set as DHCP or PPPoE, then LAN 1 will be disabled. Refer to [“LAN 1”](#).

- Enter the **Start IP Address**. It is the starting IP Address to be assigned to the DHCP clients. The DHCP Server will start assigning IP Addresses to the DHCP Clients from this IP Address onwards.
- Enter the **Number of Hosts** (that is the number of clients) to be assigned IP Addresses by the DHCP Server.
- Enter the **Subnet Mask** to be assigned to the DHCP clients.
- Enter the **DNS Address** to be assigned to the DHCP clients.
- Enter the **Lease Hours**. This is the maximum time for which the IP Address will be allocated to the DHCP client. Valid Range: 1 to 192 hours. DHCP clients should renew their lease within the Lease Hours. If the clients do not renew their lease before the expiry of the configured Lease Hours, the server will free the IP Address and this IP Address may be assigned to another DHCP client in LAN.
- Click **Save**.

Broadband Settings

The NVRX/NVRX P2/HVR supports mobile broadband as one of the modes of communication for remote access. The appropriate broadband USB dongle has to be inserted into the USB port available on the device for broadband communication.

In order to configure the parameters for mobile broadband communication, Select **Network Settings** and click on **Broadband** option. The Broadband Settings page appears as shown below:

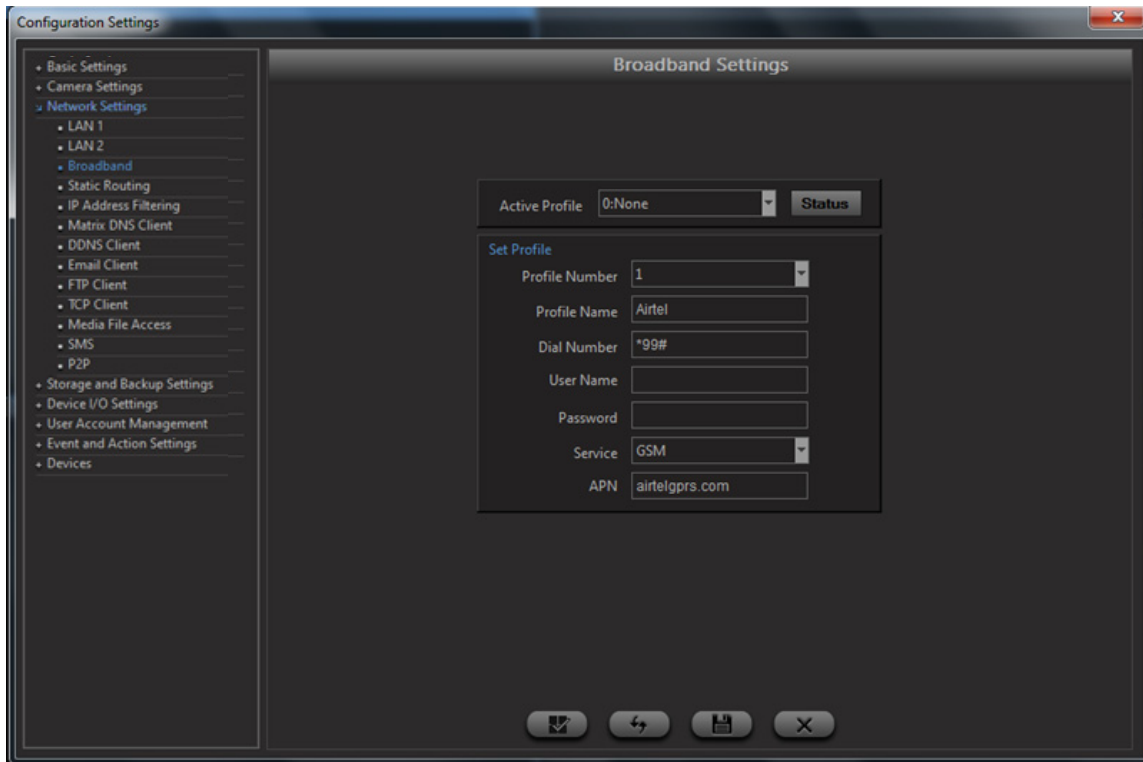

The following broadband network parameters can be configured from this page:

- **Active Profile:** In the event of having multiple broadband options, select the one currently connected to the USB port of the HVR by scrolling the arrows. The options are Airtel, BSNL, Vodafone, TATA Photon+ and Reliance.
- **Profile Number:** Each profile can be assigned a unique profile number. Select a number for this profile by scrolling the arrows.
- **Profile Name:** Specify a user friendly profile name for the connection.
- **Dial Number** - Specify the dial number as provided by the service provider which needs to be dialled to get connectivity. For example the dial number for Airtel is ***99#**.
- **User Name** - Specify the user name for the authentication.
- **Password** - Specify the password for the authentication.
- **Service** - Select the type of service from the options of GSM and CDMA.
- **APN** - Specify the access point name which is a URL specific to the service provider. It is required only if service selected is GSM.

Profile Number	Profile Name	Dial Number	Service	APN
1	Airtel	*99#	GSM	airtelgprs.com
2	BSNL	*99***1#	GSM	Bsnl.net
3	Vodafone	*99#	GSM	Portalnmms

Profile Number	Profile Name	Dial Number	Service	APN
4	TATA Photon+	*777	CDMA	NA
5	Reliance	#777	CDMA	NA

Click on the **Status** button to view the current status of the broadband connection.

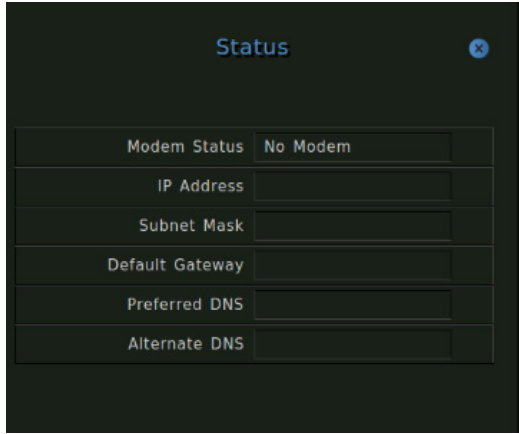

Static Routing

This option enables the administrator to program the NVRX/NVRX P2/HVR to forward packets to clients out of predetermined LAN ports. This option enables the administrator to define routes through a network by fixed paths (statically). This functionality enables the administrator to map destination addresses to the LAN ports of the SATATYA device. The main benefit of static routing is bandwidth optimization as well as enhancing the resource efficiency of the device.

In order to configure the parameters for static routing, Select **Network Settings** and Click on **Static Routing** option. The Static Routing page appears as shown below:

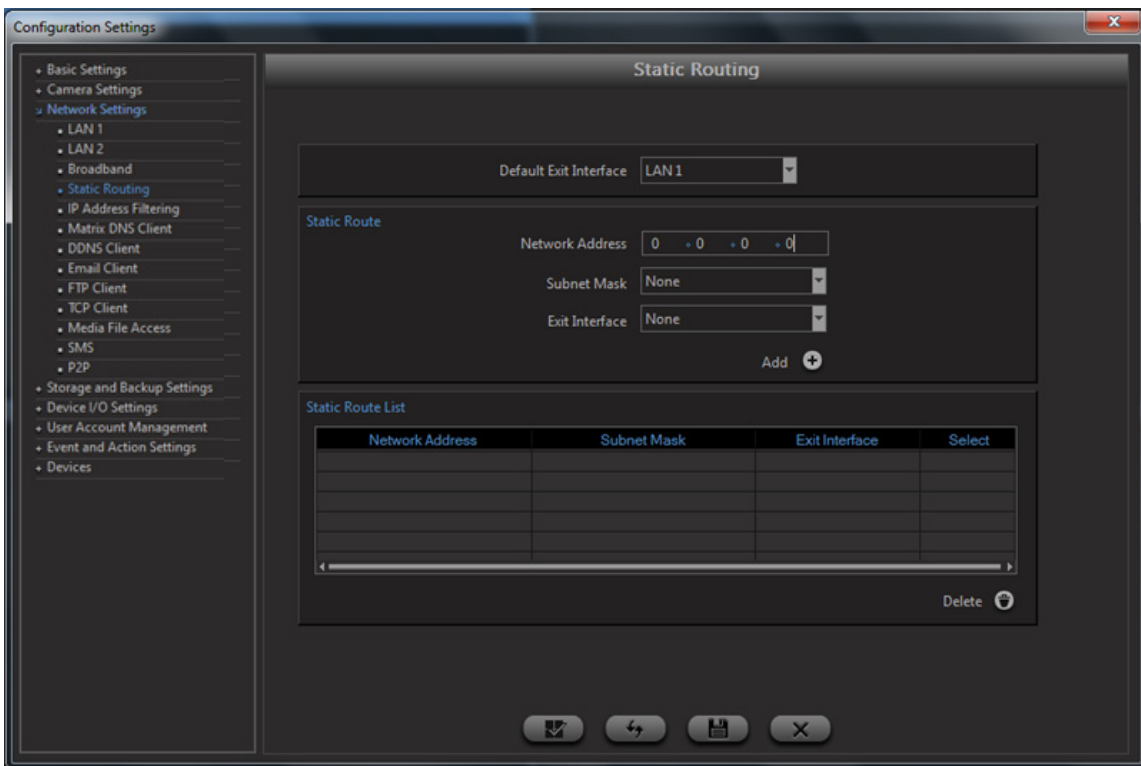

The following static routing parameters can be configured from this page:

- **Default Exit Interface:** In the event of a client not in the same subnet of the LAN ports then the system routes the packets through the default communication interface. Select the default exit interface from the drop-down list. The options are LAN and Broadband.
- **Network Address:** Specify the destination IP address of the client to which the packets are to be routed.
- **Subnet Mask:** Select the subnet mask for this route.
- **Exit Interface** - Select the communication port from the drop-down list which will route the packets to the destination IP address. The options available will be other than the default exit interface.

Click on the **Add** button to add the entry to the grid in the **Static Route List** section.

Click on the **Save** button to save the settings.

IP Address Filtering

This option enables the administrator to define and manage the computers on the network which can log into the NVRX/NVRX P2/HVR device client application. This functionality also enables the administrator to create a denial list of workstations which will be blocked from accessing the application.

In order to access this option, Select **Network Settings** and Click on **IP Address Filtering** option. The IP Address Filtering page appears as shown below:

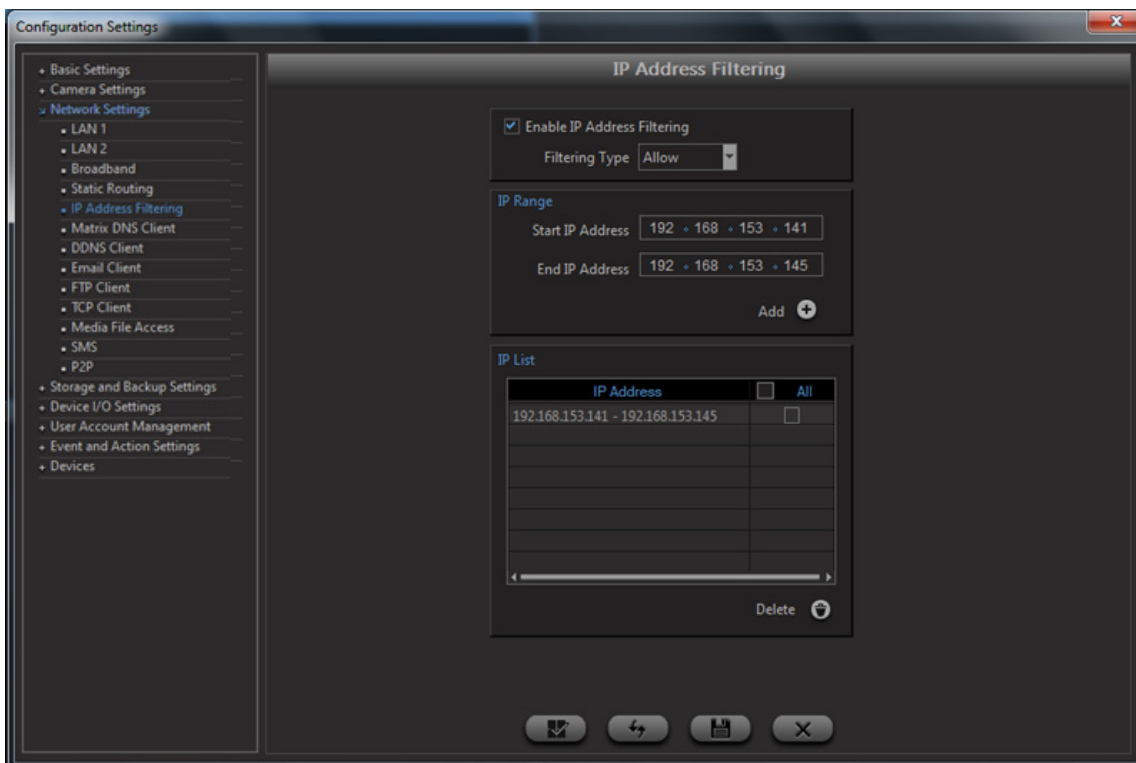

The Filtering Mode option enables the user to Allow or Deny an individual IP or a range of IPs from logging into the system. Check the box to **Enable filtering**.

Select the **Filtering Type** from the drop-down list. The options available are:

- Allow
- Deny

The IP Range option enables the user to define the **Starting** and **Ending** IP Address which shall be filtered as per the selected mode. The user can also specify a single IP Address by specifying it as the starting or ending IP Address.

Click on **Add** button to add the specified IPs.

The **IP List** section enables the user to view the configured IP Addresses as well select the desired ones and delete the same from those listed. Select the desired IP Addresses to be deleted by checking the check box against each and click on Delete button. The user can also select the entire listed IP Addresses by checking the 'Delete' check box, at the top of the column.

Matrix DNS Client

To access this functionality, go to **Network Settings** and Click on **Matrix DNS Client** option. The Matrix DNS Client Settings page appears as shown below:

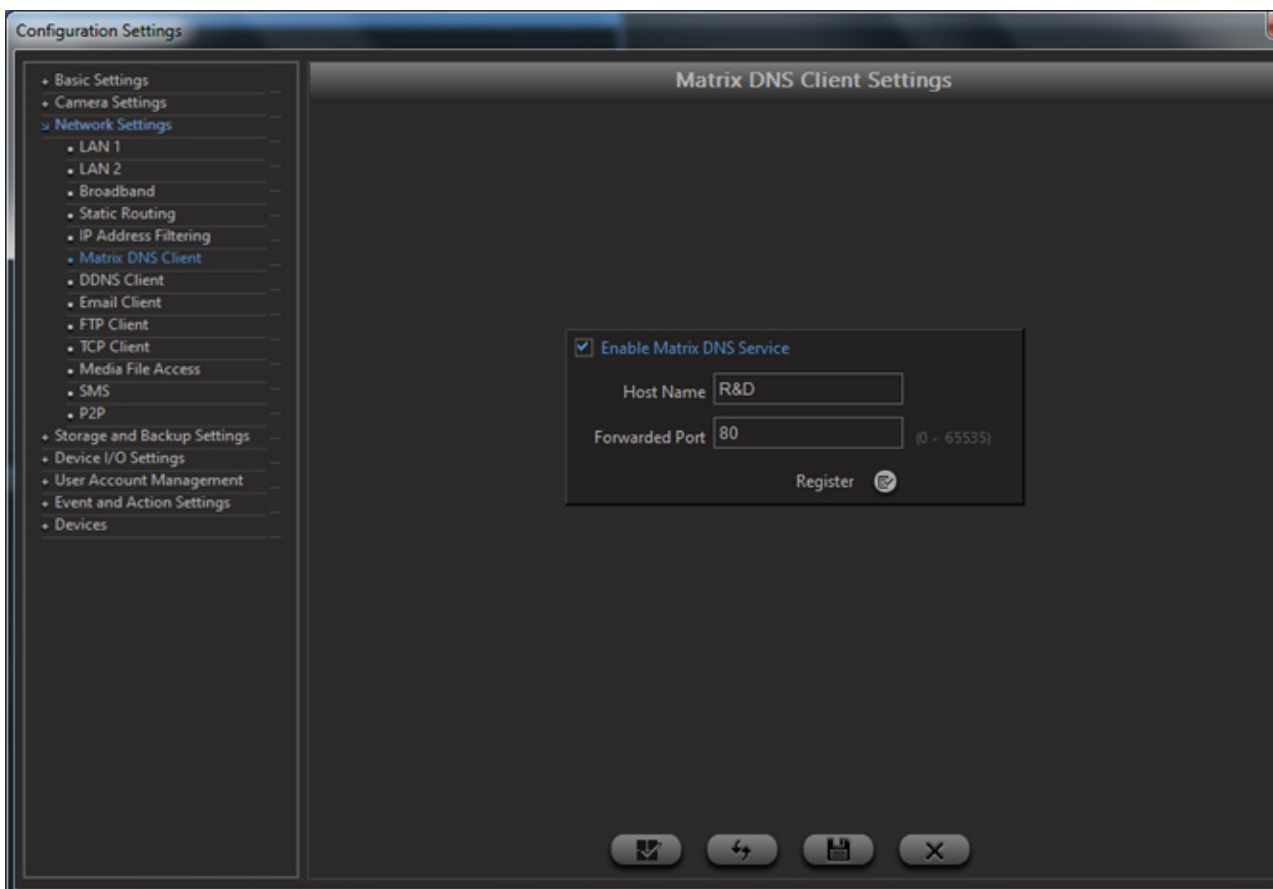

In order to enable this functionality, check the **Matrix DNS Service** box.

Enter the desired **Host Name** and **Forwarded HTTP Port**.

On clicking on **Register** button, device will send request to the DNS server containing MAC Address, IP Address, Host Name & Forwarded Port. Server will check whether MAC address is registered or not. If found unregistered then it will register it first and will then update the entered Host Name & Port against the MAC address of the device which is unique.

The Server may respond by giving following messages:

- 1) **Registration Successful:** This message is displayed only when the server successfully registers the entered host name and forwarded port.
- 2) **Registration Failed.Try Again:** This message is displayed when the server fails to register the entered host name & forwarded port.
- 3) **Host Name is already assigned to other Device:** This message is displayed when the server encounters a request for a host name that is already registered with any other device.

In the event of specifying the host name as “qa”, the user can now access the NVRX/NVRX P2/HVR from the Internet by specifying the following URL in the web browser: <http://www.qa.matrixdnserv.com>

DDNS

To access this functionality, go to **Network Settings** and Click on **DDNS Client** option. The DDNS Client Settings page appears as shown below:

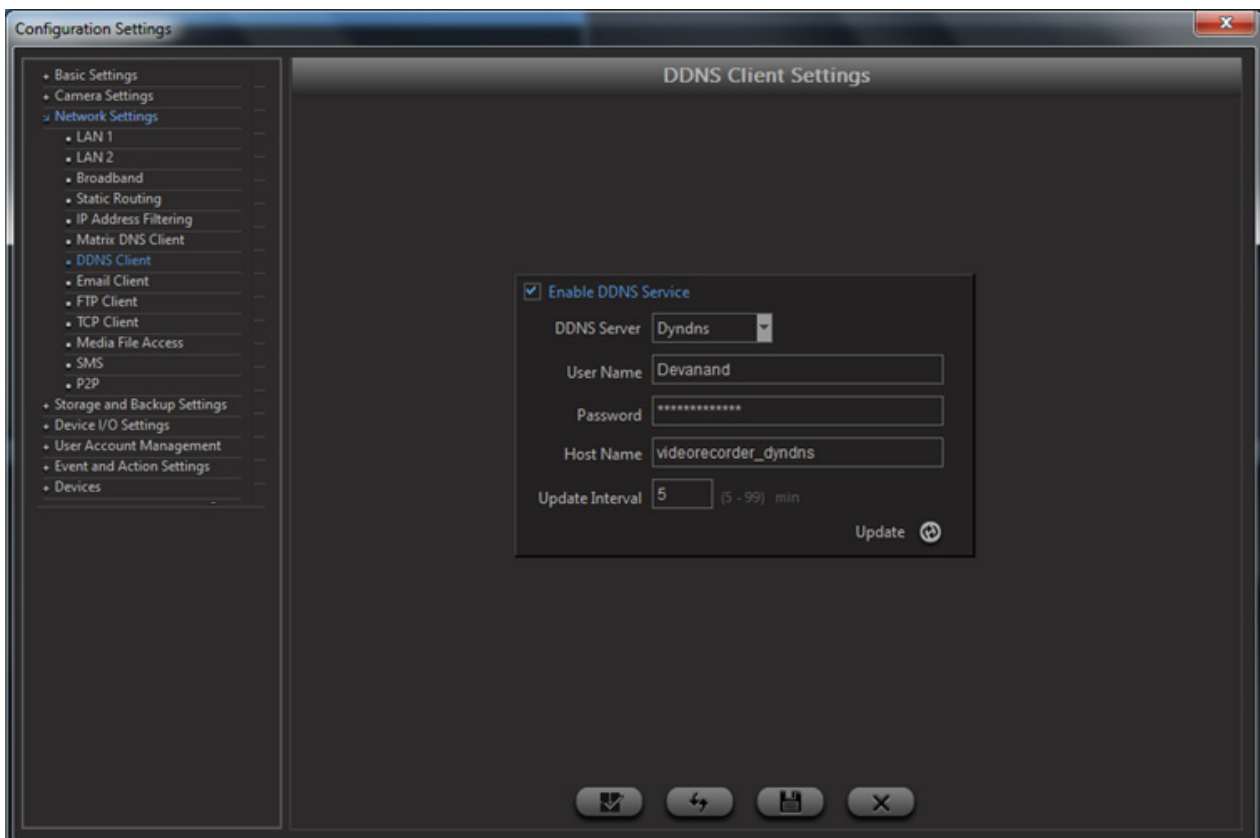

Enable DDNS Service: To configure the DDNS settings, Check the box to Enable the DDNS Service. The DynDNS option appears in the DDNS Server field by default and cannot be changed as shown in the above figure.

User Name: Specify the User Name as registered in the DynDNS network.

Password: Specify the Password as registered in the DynDNS network.

Host Name: Specify the host name as registered with the DynDNS web site.

Update Interval: Specify the Update Interval in minutes.

Click on the **Update** button to update the DynDNS site with the current IP of the device.

Click on **Save** once done.

Email Client Settings

The Matrix NVRX/NVRX P2/HVR provides various event based user alert functionalities. This option enables the system to send mails with defined text and subject to the specified users.

In order to configure the parameters of the mail server, Select **Network Settings** and Click on **Email Client** option. The Email Client Settings page appears as shown below:

The screenshot shows the 'Email Client Settings' configuration window. The left sidebar lists various settings categories, with 'Email Client' selected under 'Network Settings'. The main configuration area includes a checkbox for 'Enable Email Service' which is checked. Below this are input fields for 'Mail Server' (smtp.gmail.com), 'Port' (25), 'User Name' (sheetalraval), 'Password' (masked with asterisks), and 'Sender's Email ID' (sheetalpandya2012@gmail.com). There is also a checkbox for 'Encryption (SSL)' which is checked. A 'Test Mail' section contains a 'Receiver's Email ID' field (kunjalelectronics@gmail.com) and a 'Test' button. At the bottom of the window are four navigation icons: back, forward, save, and close.

Check the box to enable the **Email Service** and configure the SMTP server settings.

User needs to ensure that an SMTP Server is available on the network. The following parameters need to be set:

- **E-mail (SMTP) Server** - Specify the Host Name/IP Address of the SMTP Server to be used to send the e-mails. for eg: smtp.gmail.com
- **Port** - Specify the TCP Port for the SMTP Service as set on the SMTP Server. for eg: 587
- **Sender's E-mail ID** - Specify the sender's E-mail ID in this field. for eg: abhishekj1991@gmail.com
- **Encryption (SSL)** - The user has been provided with the option to enable/disable the SSL feature.
- **User Name** - Specify the user name as set in the e-mail account. for eg: abhishekj1991@gmail.com
- **Password** - Specify the password as set in the e-mail account.
- **Receiver's E-mail** - Specify the receiver's E-mail ID in this field. for eg: sheetalpandya2012@gmail.com

Click on **Test** button to test the connection.

Click on **Save** to save the changes.

The Subject of the mails can be defined from the Event and Action option as explained later in this section.

FTP Client Settings

The NVRX/NVRX P2/HVR has the capability to upload images to an FTP server based on various event triggers. This option enables the user to configure the FTP server settings. The administrator can define up to two FTP servers which can be then configured for uploading images or backup of image files from the NVRX/NVRX P2/HVR.

In order to configure the parameters of the ftp server, Select **Network Settings** and Click on **FTP Client** option. The FTP Settings page appears as shown below:

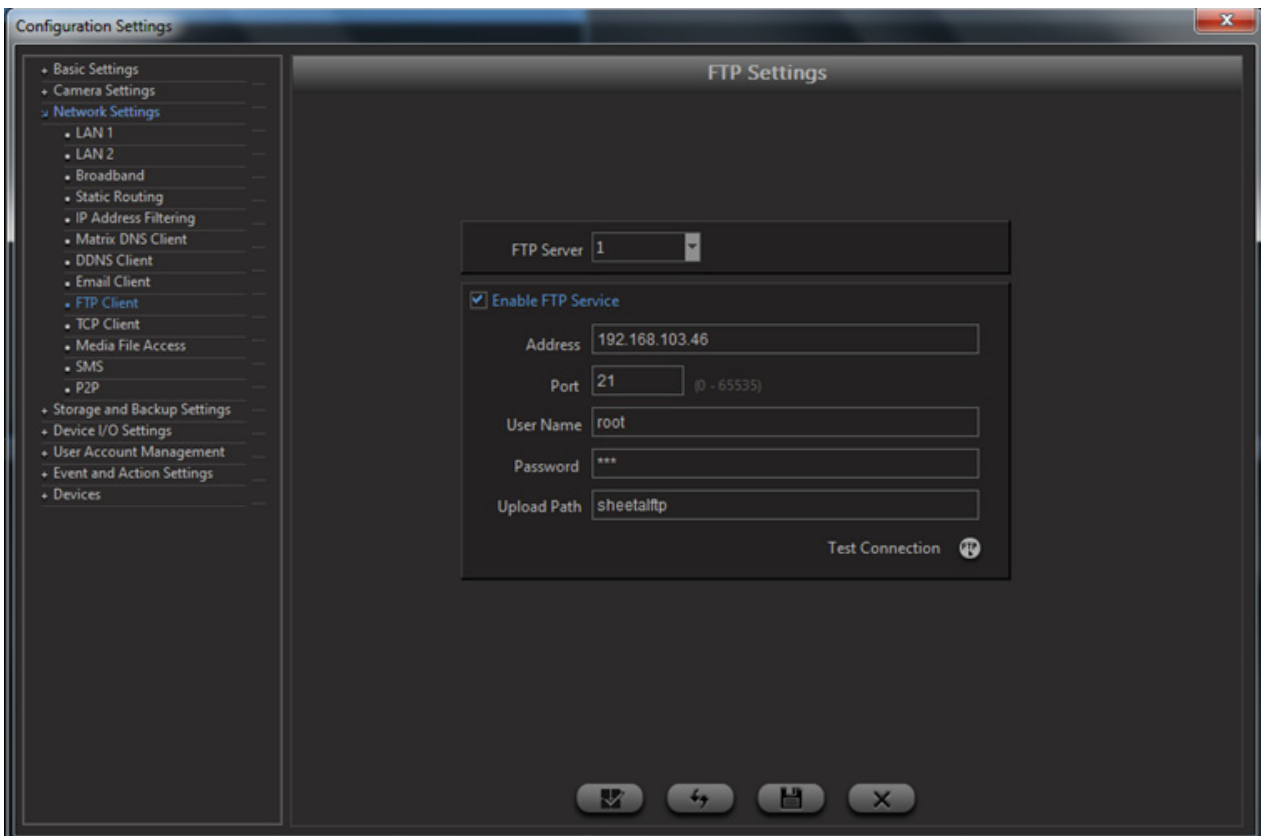

Check the box to enable the **FTP Service** and configure the FTP server settings

The following parameters need to be set:

- **FTP Server**- Select the FTP Server 1 or FTP Server 2 by scrolling the arrows.
- **FTP Address** - Specify the Host Name/IP Address of the FTP Server to be used for uploading the images. For eg: 192.168.103.46
- **Port** - Specify the FTP Port for the FTP Service as set on the FTP Server. For eg: 21
- **User Name** - Specify the user name as set on the FTP Server that shall be used for authentication verification.
- **Password** - Specify the password as set on the FTP Server that shall be used for authentication verification.
- **Upload Path** - Specify the path of a folder on the FTP Server, where the images will be stored.

Click on **Test Connection** button to verify the connection.

Click on **Save** to save the changes.

TCP Server Settings

As mentioned earlier, the NVRX/NVRX P2/HVR provides various event based user alert functionalities. This option enables the system to send alerts to a computer which has a resident tcp server application.

In order to configure the parameters of the TCP server, select **Network Settings** and Click on **TCP Client** option. The TCP Settings page appears as shown below.

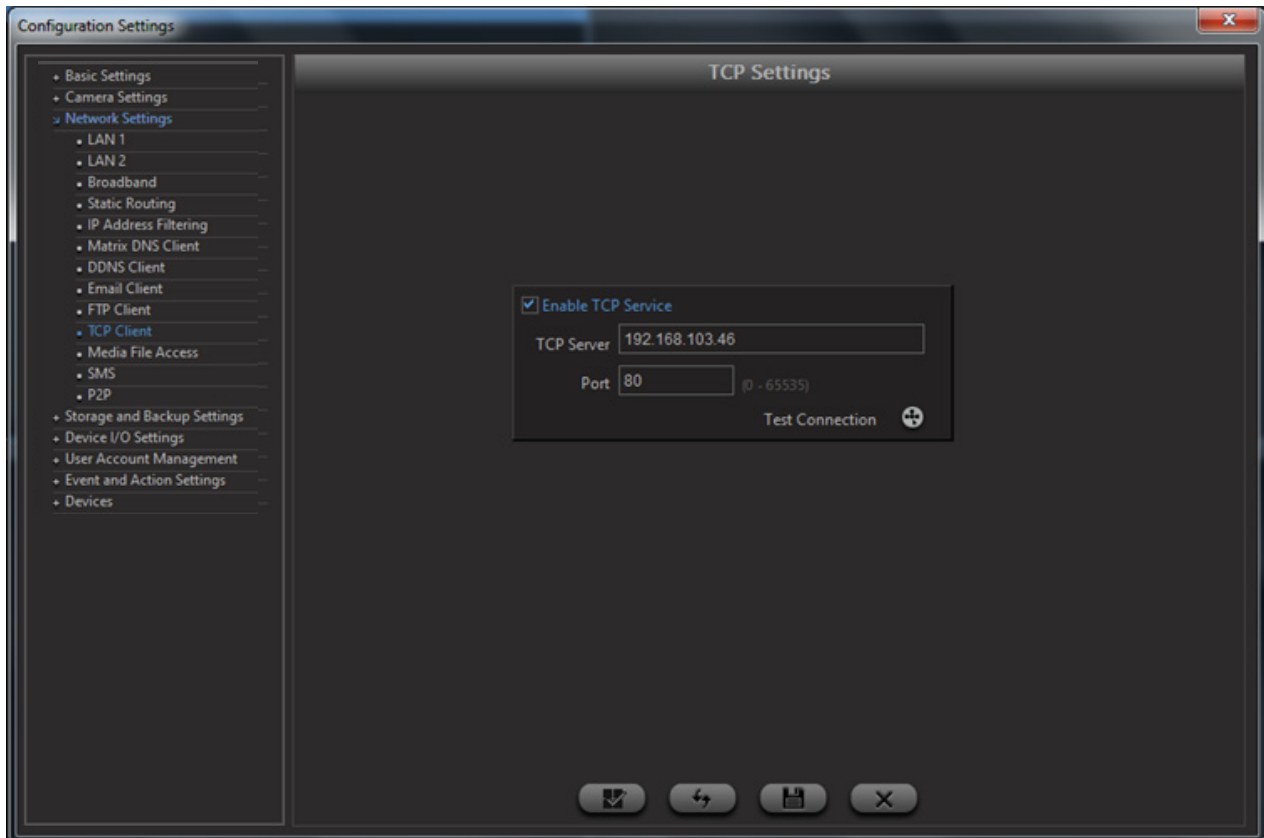

Check the box to enable the **TCP Service** and configure the TCP server settings.

The following parameters need to be set:

- **TCP Server** - Specify the Host Name/IP Address of the TCP Server to be used for notification. For eg: 192.168.153.142
- **Port** - Specify the TCP Port as set on the TCP Server. For eg: 65535

Click on **Test Connection** button to verify the connection.

Click on **Save** to save the changes.



In order to use the remote control while configuring the network settings, the user needs to first perform the binding procedure by pressing the Address key.

Media-File Access

This functionality enables the user to remotely access the network for recorded files stored inside the camera storage. The files can be accessed using **FTP**, that is File Transfer protocol used to transfer files from FTP Server to the Remote Client.

Click on **Media File Access** option under the Network Settings. The Media File Access Settings page appears:

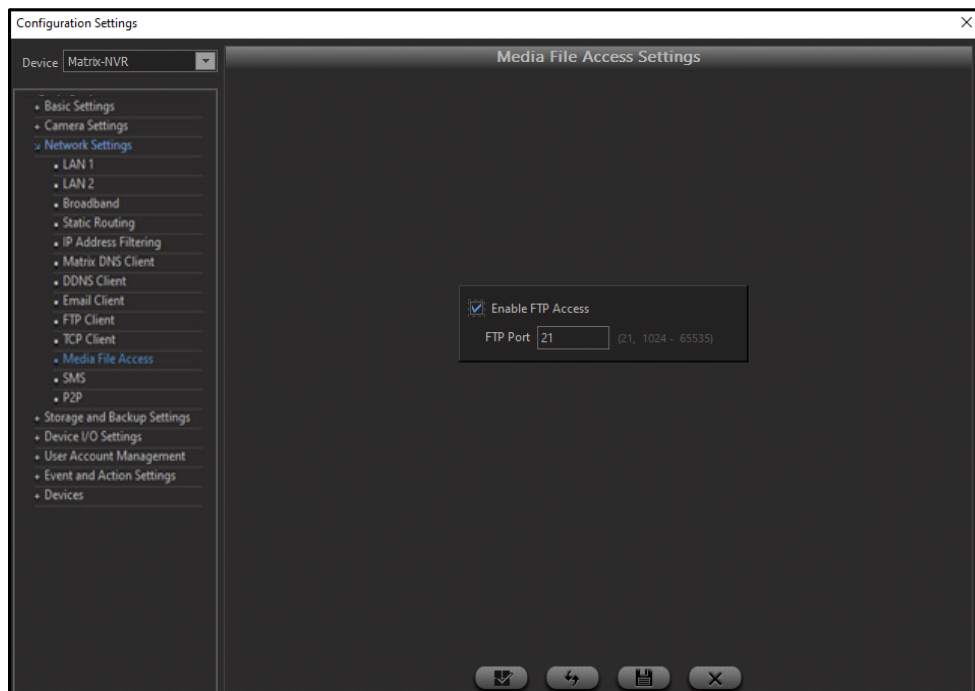

Select the **Enable FTP Access** check box. On enabling this option, the users can access the folders on the NVRX/ NVRX P2/HVR.

The following ftp path has to be specified in the windows explorer or any browser of the client computer: ftp://(ip address for HVR)

The system will prompt for the user name and password as defined on the NVRX/NVRX P2/HVR. Enter the same in the appropriate fields and click on OK to access the folders.

In **FTP Port** specify the listening port of the FTP Server on the NVRX/NVRX P2/HVR.

The users have only view and copy rights for the above option.

Click on **Save** once done.

SMS Settings

As mentioned earlier, the NVRX/NVRX P2/HVR provides various event based user alert functionalities. This option enables the system to send alerts to a configured cellphone number using either the web based SMS servers or the broadband connection of the NVRX/NVRX P2/HVR.

In order to configure the parameters of the SMS service, Select **Network Settings** and Click on the **SMS** option. The SMS Settings page appears as shown below.

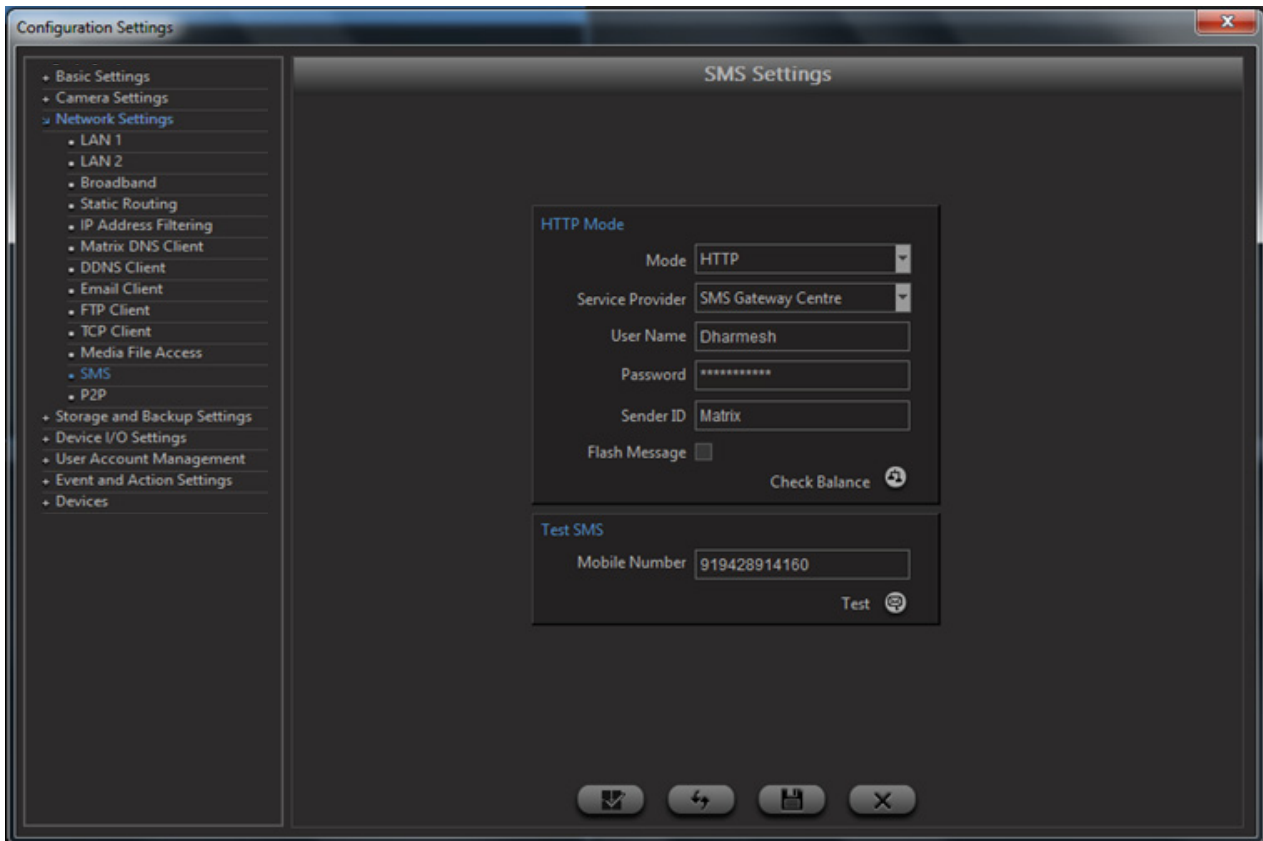

Check the box to enable the **SMS Service** and to configure the parameters of the SMS service provider.

Select the **Mode** via which the alert SMS is to be sent. The options are **HTTP** to send SMS via web service and **BROADBAND**.

Select the **Service Provider** for the HTTP mode by scrolling the arrows. The options are **SMS Gateway Center**, **SMS Lane**, **Business SMS** and **Bulk SMS**.

Specify the user account's **Username** and **Password** as registered on the service provider's site.



*If you have selected **SMS Lane** as the Service Provider, enter the Client ID in User Name and API Key in Password.*

Specify the **Sender ID** used to send the sender id in the message.

Flash Message: Some service providers also provide the option to send flash messages instead of text messages. Select this check box to send flash messages.

Check Balance: Click on this button to view the credit balance for the account. However, this operation is possible only after saving the configured service parameters. Click on the **Save** button to save the configured service parameters.

The user can now enter a phone number in the field provided and click on the **Test** button to test the settings.



*If you have selected **SMS Lane** as the Service Provider, the Test activity will not be functional.*

Monitor Client (Not Applicable for NVRX and NVRX P2 series)

Monitor Client displays the health status of device and informs about the occurrence of various events. For this the Monitor Client service should be enabled from the Network Settings of the Device.

To configure the parameters for Monitor Client, select **Network Settings** and Click on **Monitor Client** option. The Monitor Client Settings page appears as shown below:

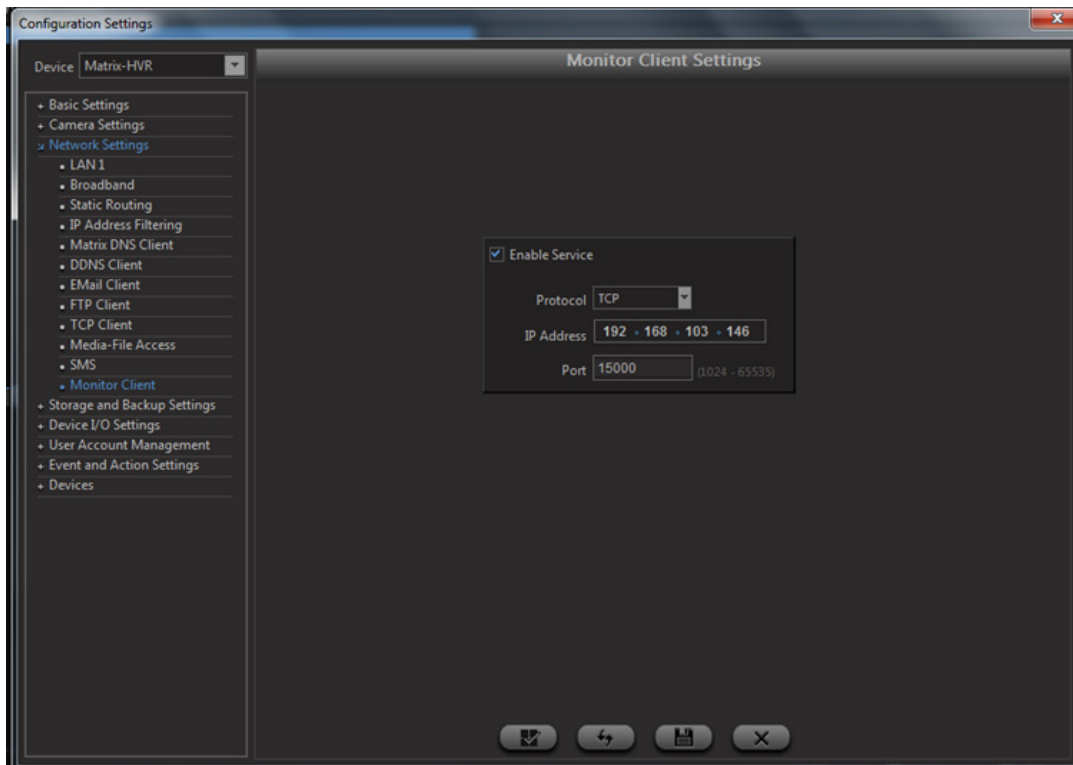

Enable Service: Check the box to enable the Monitor Client Service.

Protocol: Select the TCP or UDP protocol for communication of SATATYA Device with Monitor Client.

IP Address: Specify the IP address of the server PC where Monitor Client application is to be used.

Port: Specify the listening Port of the server.

Click on **Save** to save the monitor client settings.

P2P



This feature is applicable to NVRX/NVRX P2 series only.

When you need to access the Device connected behind the NAT using the Mobile Application (SATATYA SIGHT), you must enable the P2P functionality.

For this feature to work without any interruption a provision of Relay Server as Fallback Server is also provided, that is, if you have enabled P2P functionality and you are facing connectivity issues, an error message “Unable to reach the device” is displayed in your application, then you can enable the Fallback to Relay Server option. This will ensure Mobile Application is connected to the Device irrespective of the NAT type.



If you enable the Fallback to Relay Server option, the packets will be routed through the Matrix Cloud Server. Matrix does not extract any data from these packets. However, if you have security concerns then do not enable this option.

To be able to access the device from the Mobile Application (SATATYA SIGHT), you need to make sure that:

- both the Device and Client are connected to the Internet.
- the same (that is P2P/ Fallback to Relay Server) options are also enabled in the Device as well as the Mobile Client.

To configure the parameters for P2P in the device, click **Network Settings** and click **P2P**. The P2P Settings page appears as shown below:

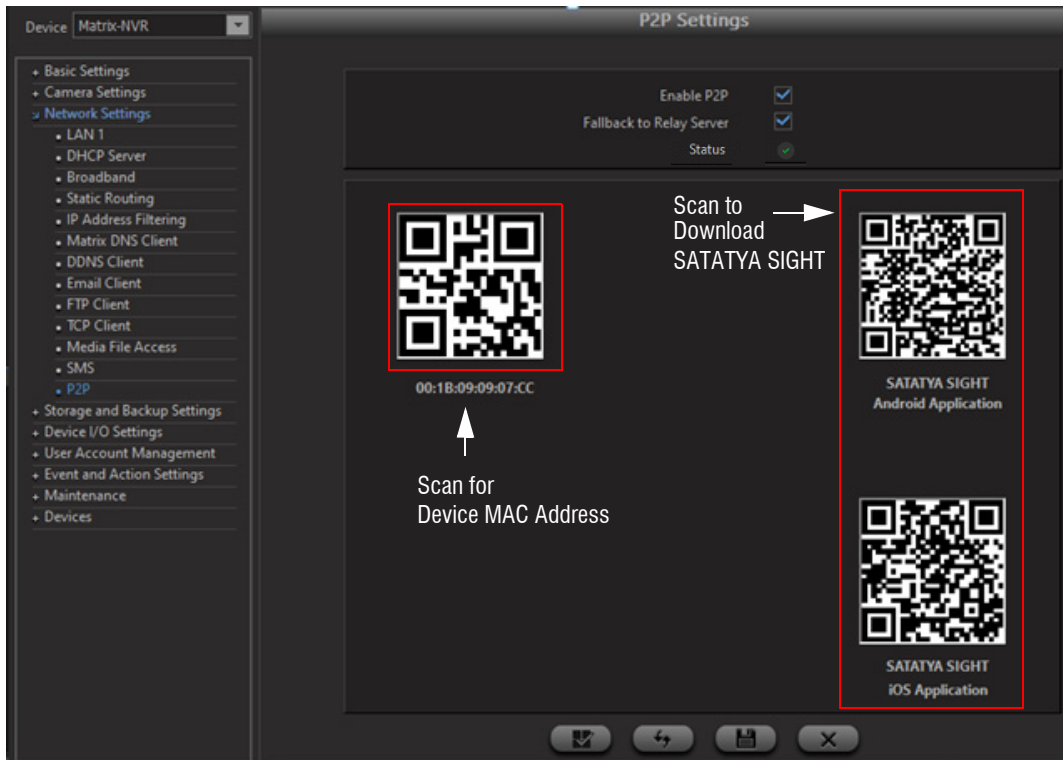

- Select the **Enable P2P** check box to enable.
- Select the **Fallback to Relay Server** check box to enable. If you have enabled P2P and are facing connectivity issues, then enabling Fallback to Relay Server option will ensure that the Mobile Application is connected to the Device irrespective of the NAT type.



Fallback to Relay Server is supported in Mobile Clients with Firmware Version V4R1.1 and later.

If you enable the Fallback to Relay Server option, the packets will be routed through the Matrix Cloud Server. Matrix does not extract any data from these packets. However, if you have security concerns then do not enable this option.

- The **Status** displays the P2P connectivity status — Connected, Disconnected.
- The MAC Address of the Device is embedded in the QR Code. This is required when you are configuring the SATATYA SIGHT in P2P Mode. If the MAC Address is not known the QR can be scanned and the same can be fetched.
- If the user needs to download the SATATYA SIGHT Android or iOS application the same can be done by scanning the respective QR Code.
- Click **Save**.

- If you need to access the Device from the SATATYA SIGHT, make sure you have done the necessary configurations in the application:
 - Configured the Name of the Device that needs to be accessed from the application.
 - Connection Mode is set as P2P.
 - Enable the Fallback to Relay Server check box if an error message “Unable to reach the device” is displayed in your application.
 - MAC Address of the Device is configured.
 - Configured the User Name and Password.

Storage and Backup Settings

The **Storage and Backup Settings** option enables the user to view the installed hard disk information on the NVRX/NVRX P2/HVR and also configure the following parameters.

- Storage Alerts
- Initializing Hard Disks
- HVR action when Hard Disk is full
- Backup recorded files at predefined schedules

[“HDD Management”](#)

[“HDD Group”](#)

[“Network Drive”](#)

[“Storage Management”](#)

[“Backup Management”](#)

[“USB”](#)

HDD Management

HDD Management is a significant feature of the system. It supports different RAID levels according to the way of storing the data in multiple physical disks interfaced to the NVR/NVRX/NVRX P2. To know more about RAID levels, See [“RAID Concept” on page 359](#).

HDD Management in NVRX/NVRX P2 series variants

To access this functionality, click **Settings > Storage and Backup Settings > HDD**. The HDD Management page appears.



The screen above shows RAID 10 Creation in NVRX variant.

To know more about RAID creation and Total Logical Volume in different NVRX series variants, See [“RAID Concept” on page 359](#).

HDD Management in other NVR and HVR variants

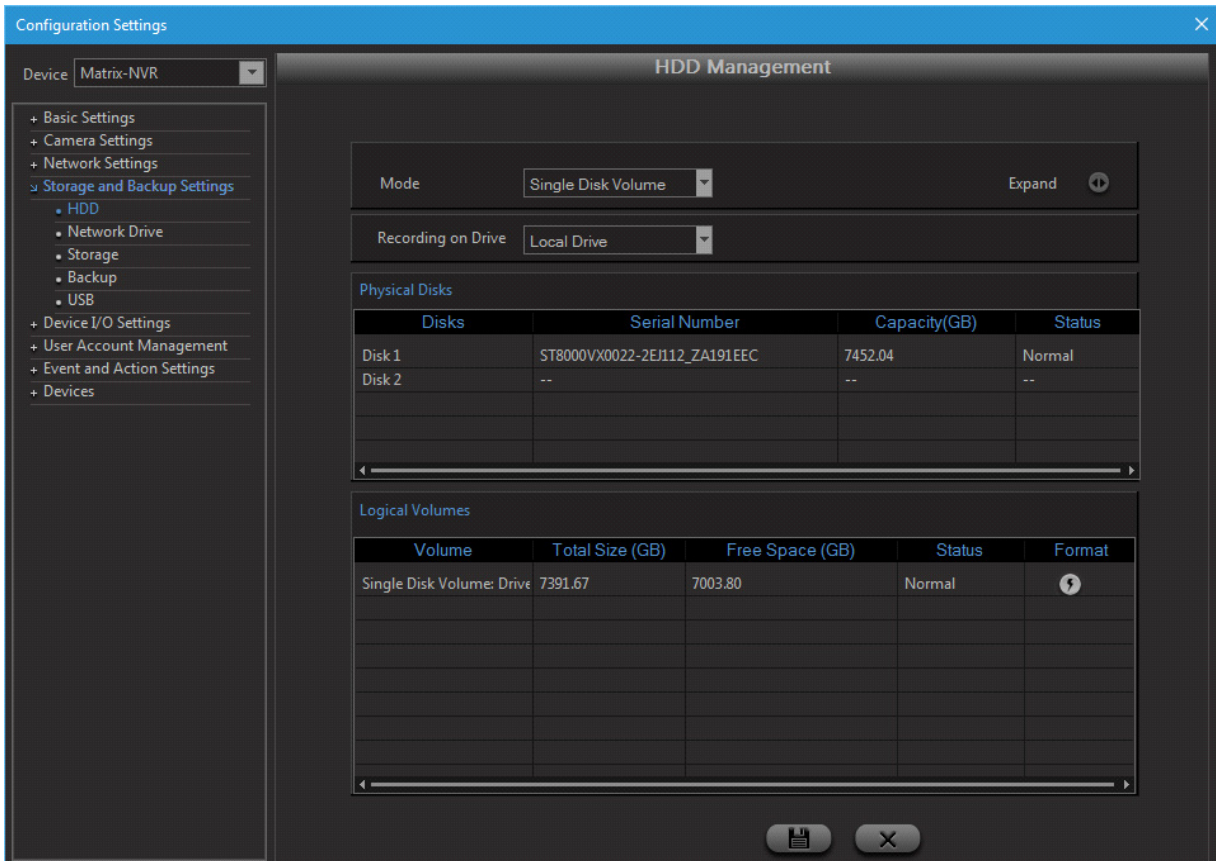

The SATATYA HVR provides the following modes for Storage management:

- Single Disk Volume
- RAID 0 (Disk Striping to enhance performance)



In HVR 1624P and HVR 0824P hard disk should be connected in SATA1 and SATA3 ports (or SATA2 and SATA 4 ports) for RAID 0 mode.

- RAID 1 (Disk Mirroring to provide fault tolerance)

Recording on Drive option enables the user to specify the storage location of the recorded files. Select the **Local** or the **Network Drives** as per the site requirements.

The **Expand** option is used in the event of the RAID 1 mode being set for the disks. This option is used to enhance the storage capacity without losing existing data.

For e.g. if the current RAID 1 configuration consists of 2 x 500GB disks and the user wants to upgrade to a 2 x 1TB RAID 1 configuration then the following steps need to be followed:

- Power down the HVR and remove one of the 500 GB disks and connect a 1 TB disk in its place.
- Power up the HVR and let the system mirror the data from the 500 GB disk to the 1 TB disk.
- Power down the HVR again and remove the second 500 GB disk and connect the other 1 TB disk in its place.

- Power up the HVR again and on completion of the reboot process, click on the **Expand** button to expand the disk mirroring volume to 1 TB.

The Physical Disks section displays the configuration and the physical status of the connected disks.

The Logical Volumes section will display the status of the disk volumes based on the configured Storage management mode. Format option is available to initialize the disks and create a new volume.

Click on **Save** once done.

Hard Disk Clean-up Pop-up

Hard Disk (HDD) clean-up pop-up allows the user to optimize the storage more efficiently.

When a certain amount of junk files are created in the HDD, this pop-up appears every time to clean the junk files either on the system reboot (local client) or when the new session is started (device client). The popup window is shown below.

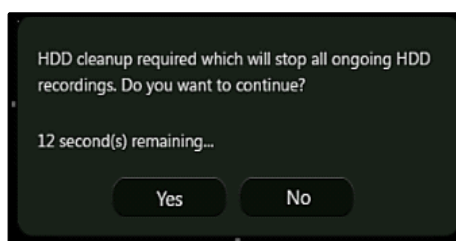

If you click on **Yes** button, the ongoing recordings will be stopped/paused and the HDD clean up process will start. More the data to be scanned more will be the time taken in HDD clean-up process. Once the HDD clean-up process completes, the recording, if scheduled will be resumed again.

If you click on **No** button, then the HDD clean-up pop-up will disappear, as a result, no HDD clean-up will be performed and the recording will be continued. The pop-up will appear again whenever a new session is started until the HDD is not cleaned.



It is recommended to clean the HDD because the junk files occupy the unnecessary space which may affect the recording process.

HDD Group



HDD Group is applicable for NVR9608X P2 only.

In NVR9608X P2, you can group the HDDs and allocate cameras to these groups.

To access this functionality, click **Settings > Storage and Backup Settings > HDD Group**. The HDD Group page appears.

The **HDD Group** displays the maximum number of Hard Disks installed in the system.

Select Volume displays the disks/RAID automatically. This is dependent on the **Mode** selected in the **Storage** tab.

Select Cameras displays all the cameras connected to the system.

You can create HDD Groups in which you can assign cameras to the desired Volumes. The recordings of these selected cameras will be stored in the selected Volumes.

For Example,

Under **Storage** tab, the **Mode** selected is Single Disk Volume.

Then, under **HDD Group** tab, all the disks will appear individually as per the number of HDDs connected.

Whereas, if the **Mode** is selected as RAID 0/1/5/10, then all the disks will appear as Logical Volumes according to the configured RAID. The maximum number of supported disks is 8.

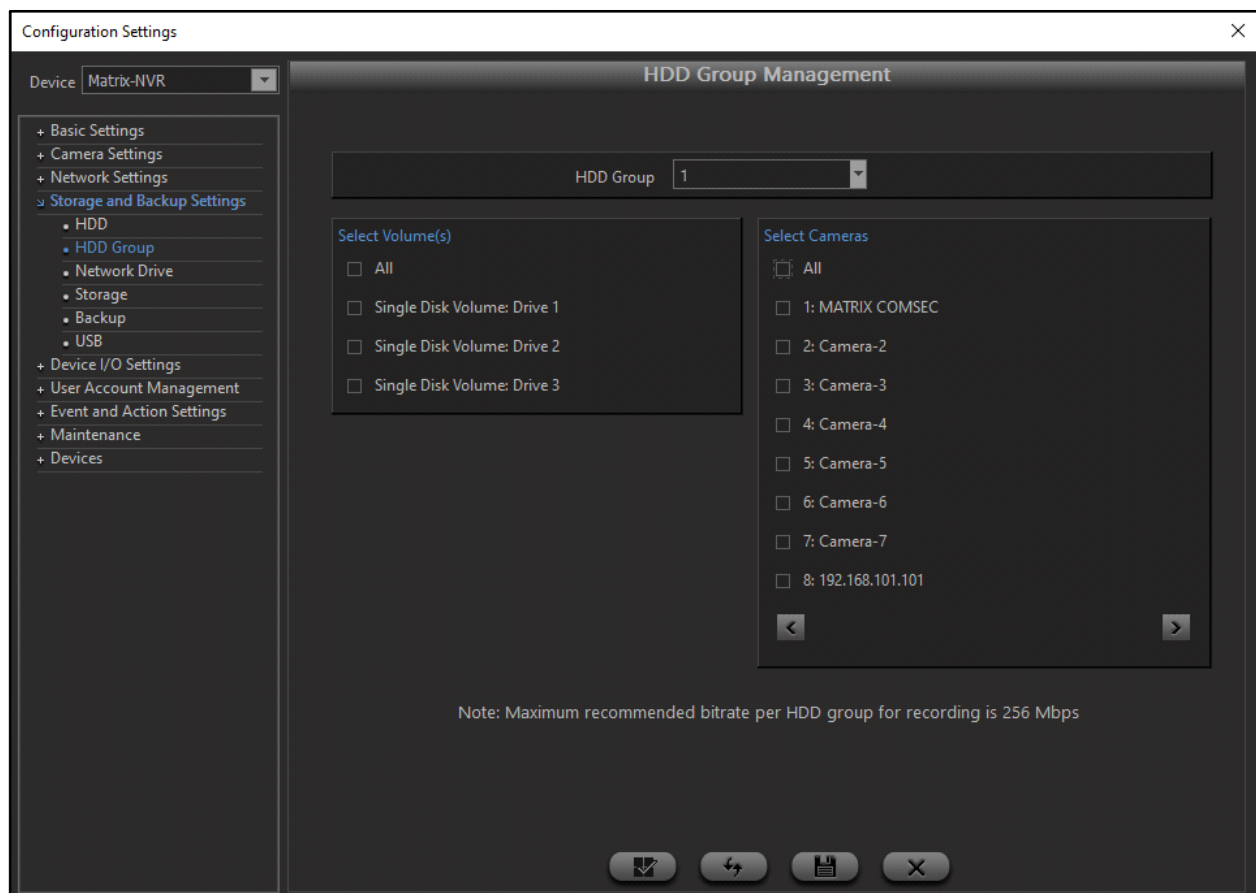

Configure the HDD Group parameters as per your requirement:

HDD Group: Select the desired HDD Group from the drop-down list to which you wish to allocate HDDs displayed under Select Volume(s).

Select Volume(s): Select the check boxes of the desired Volume(s) to be allocated to the selected HDD Group. For Example, HDD Group 1 can have Disk 1 and Disk 2, Group 2 can have Disk 3, Disk 4 and Disk 5 and so on. The Group number will be displayed once the disks are allocated to a group.

Select Cameras: Select the check boxes of the desired cameras that you wish to allocate to the Volumes assigned to the selected HDD Group. The recording of the selected cameras will be stored in the Volumes assigned to the selected HDD Group. The Group number will be displayed once the cameras are allocated to a group.

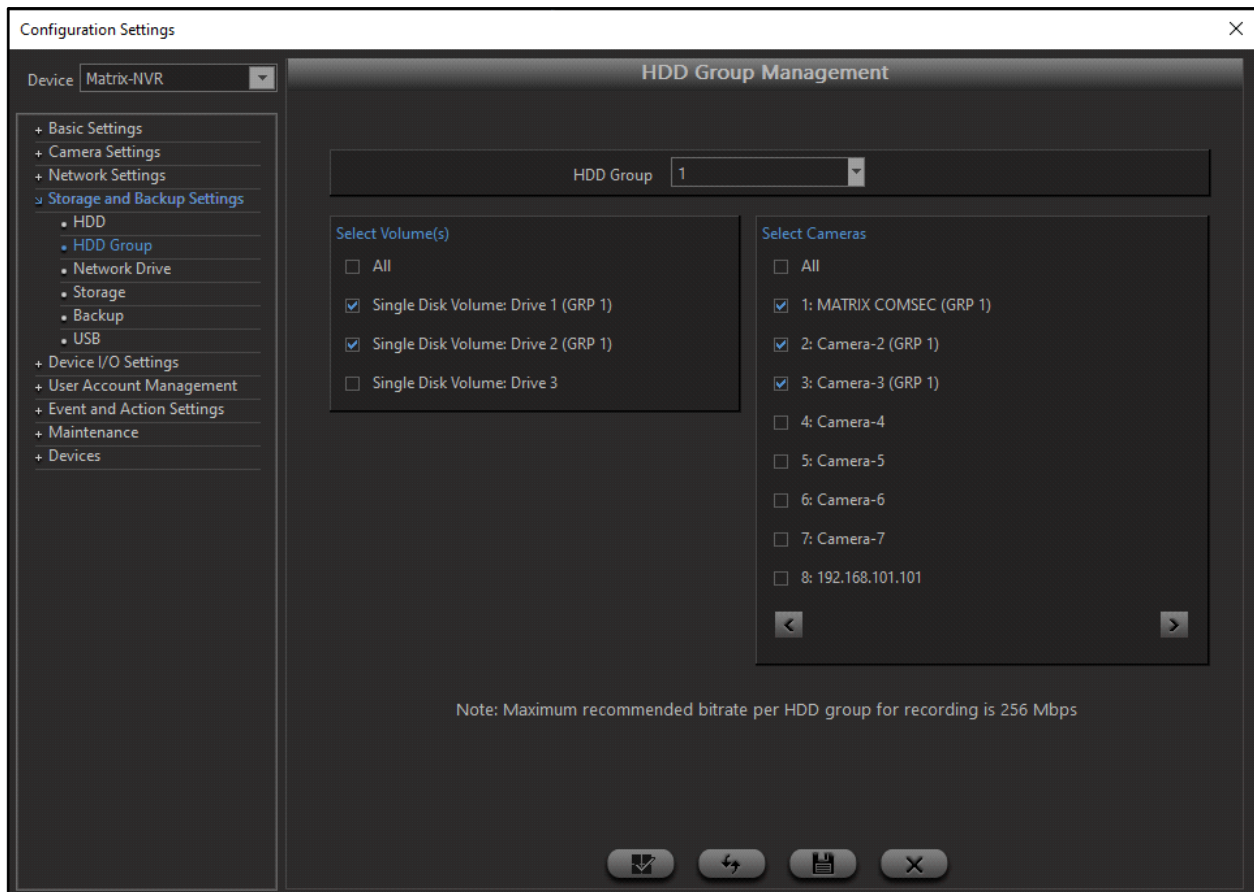

One Volume can be allocated to any one of the HDD Groups. Similarly, one camera can be allocated to any one of the Volume within a HDD Group. When a Volume which is already allocated to a group is selected to be allocated to other group, the following pop-up appears.

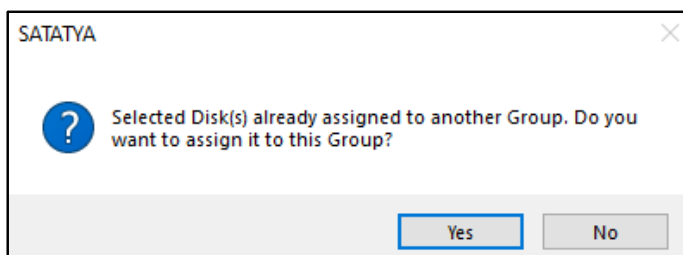

Click **Yes** to move the Volume to the selected group or click **No** to discard.

Similarly, when a camera which is already allocated to a group is selected to be allocated to other group, the following pop-up appears.

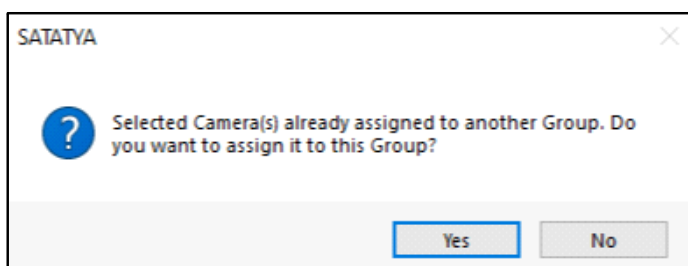

Click **Yes** to move the camera to the selected group or click **No** to discard.

Click **Save** to save the configuration. All the ongoing recording will stop and will resume as per the new HDD Group configuration.



It is recommended that the total bitrate of all the cameras in a HDD Group should be 256 Mbps for optimum performance.

Network Drive

This functionality allows the user to create more external storage space by defining a network drive. It also allows the end users to upload images, take backup as well as start recordings on the defined drive.

Select **Storage and Backup Settings** option and Click on the **Network Drive** option. The Network Drive page appears as shown below:

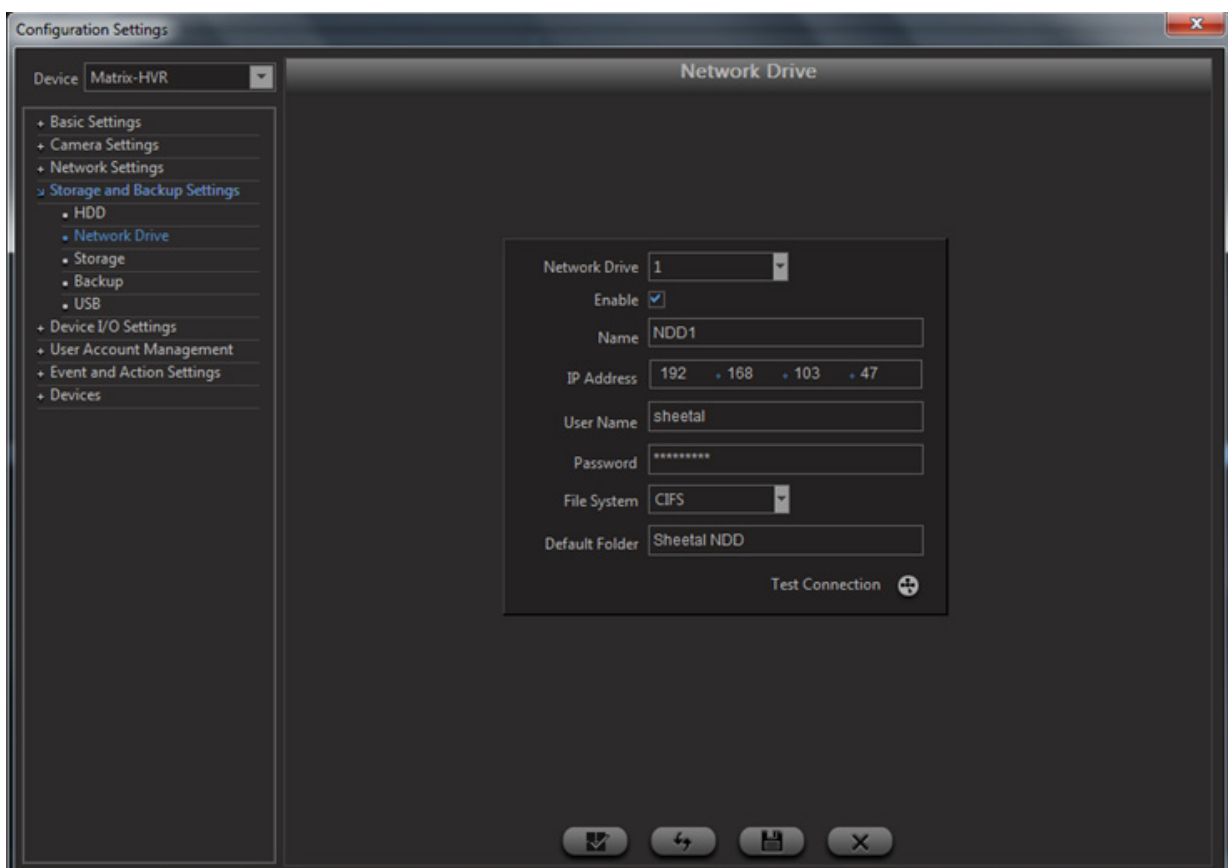

Network Drive: Select the network drive number from the drop-down list.

Click on **Enable** checkbox to activate the configured network drive.

Specify a user friendly name of the network drive in the field **Name**.

Specify the **IP Address** of the network drive.

Enter correct **User Name** and **Password** that will be sent for verification to the Network Drive.

File System: This field will specify the file system supported by the Network Drive PC i.e. CIFS or NFS.

Default Folder: This field will store the path of the folder on Network Drive, where the media files has to be recorded and transferred.

Storage Management

The NVRX/NVRX P2/HVR continuously monitors the free space on the hard disk. The user can define a set of actions for effective storage management using this option.

To access this functionality, click on the **Configuration** button from the left pane of the device client page. Select the **Storage and Backup Settings** option and click on **Storage**. The Storage Management Page appears as shown below:

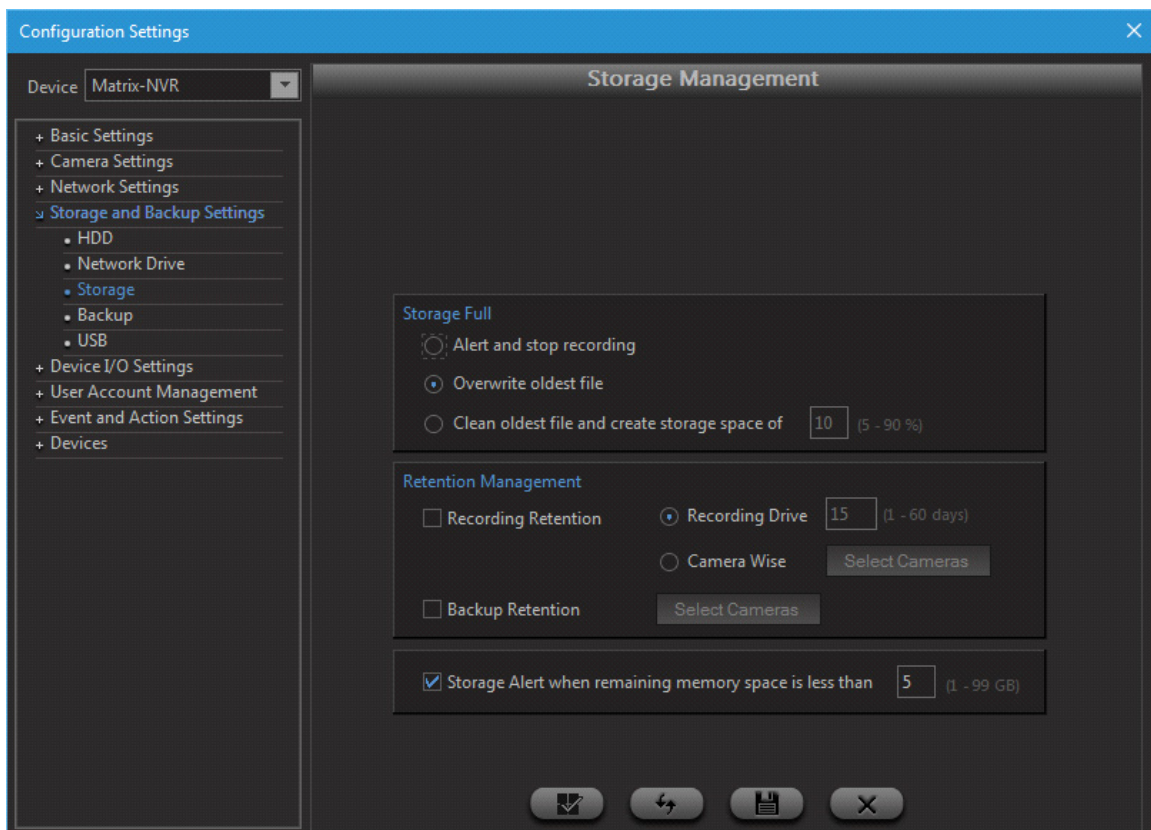

Storage Full

This section enables the user to define the action to be taken on disk full event. The options available are:

- Alert and stop recording (Alert could be in the form of a notification or alarm)
- Overwrite oldest file
- Clear oldest files to create storage space of defined percentage

Retention Management

This section enables the user to retain data of Recordings and Backups by configuring retention duration in day(s).

Recording Retention: Enable this checkbox to configure Retention Days for recordings. You can do it either for whole Recording Drive or Camera Wise recordings.

- If you choose to select **Recording Drive** option, then specify duration in days. This will clean up files older than the specified days from the recording drive for all the cameras.
- If you choose to select **Camera Wise** option, then you can specify retention duration for each camera individually, by clicking on **Select Cameras** as shown below. This will clean up files older than the days specified for each individual camera.

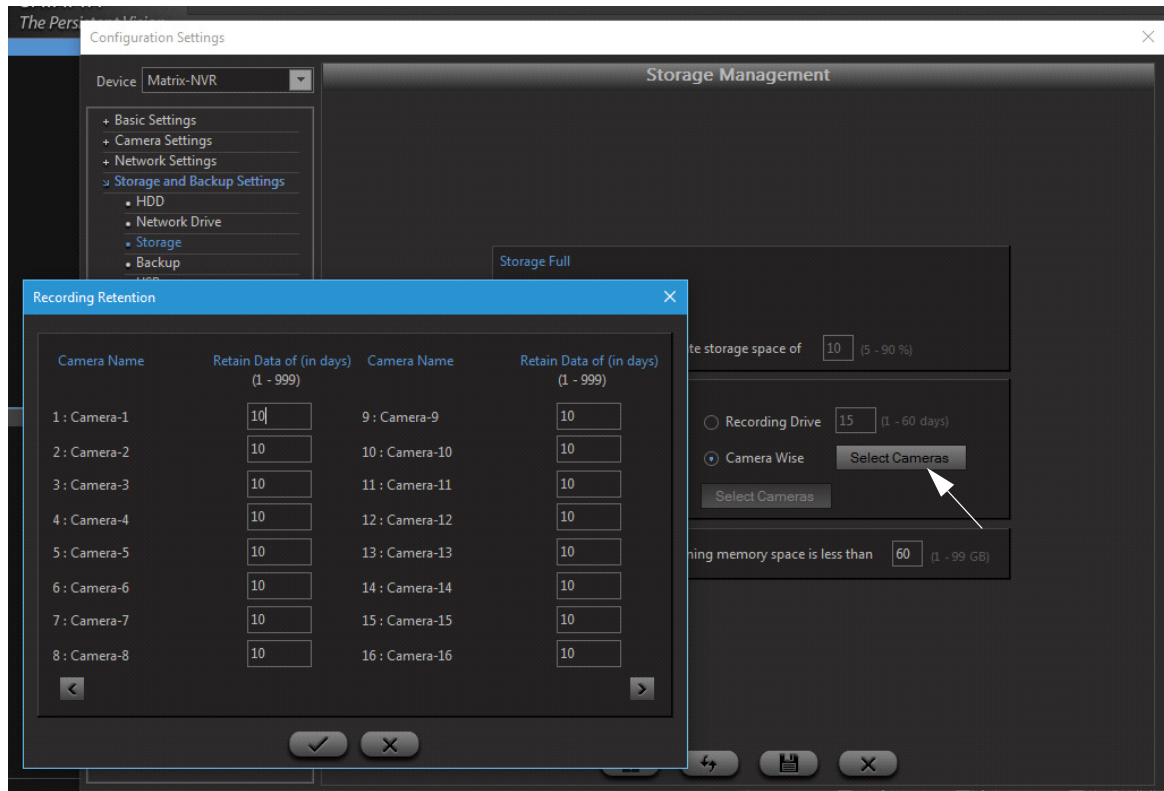

- **Backup Retention:** Enable this checkbox to configure Retention Days for Backup files. Click on **Select Cameras** button and specify retention duration for each camera individually as shown below. This will clean up files older than the days specified for each individual camera.

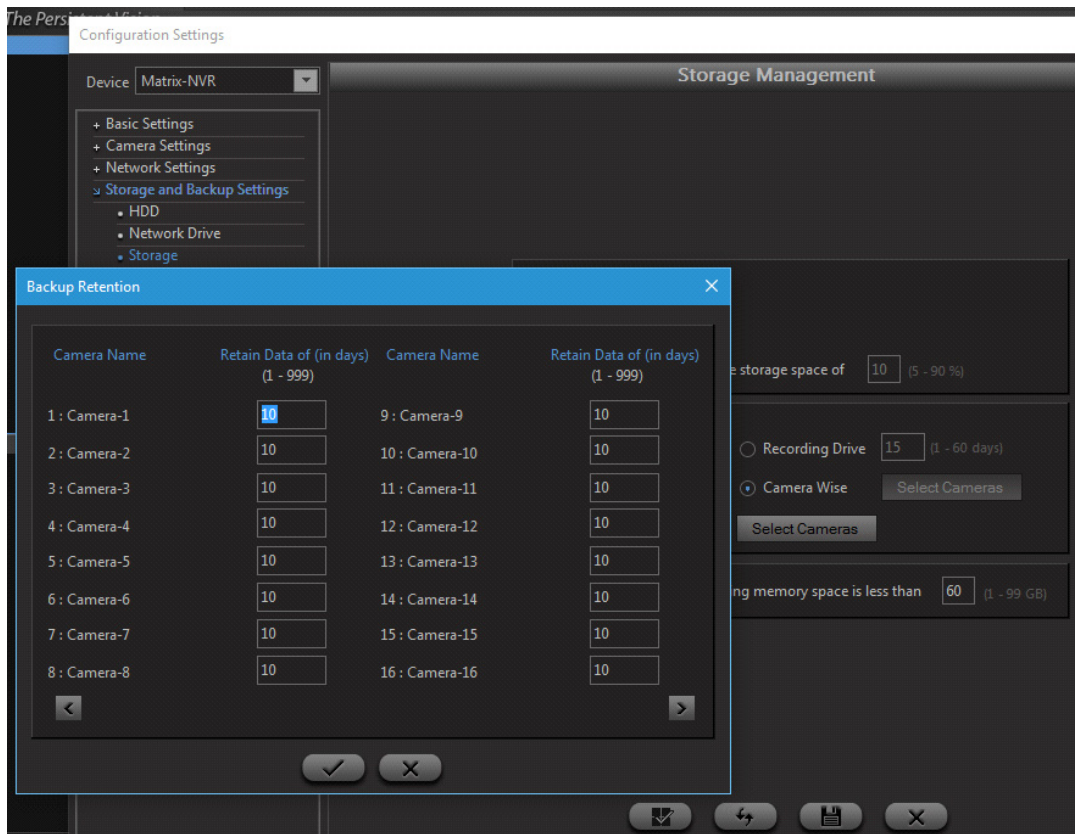

The user can also set an alert in the event of the free space going below a certain threshold level.

Check the **Storage Alert** box to enable this functionality. Specify the free space threshold level in GB in the space provided.

Click on **Save** once done.

Backup Management



Backup depends on the speed of the Hard Disk, hence configure the Backup duration wisely.

The SATATYA Devices enables the user to backup recorded files at predefined schedules to a USB drive, Network drive or an ftp location.

In order to access this functionality, click on the **Configuration** option from the left pane of the device client page. Select the **Storage and Backup Settings** option and Click on **Backup**. The Backup Management page appears as shown below:

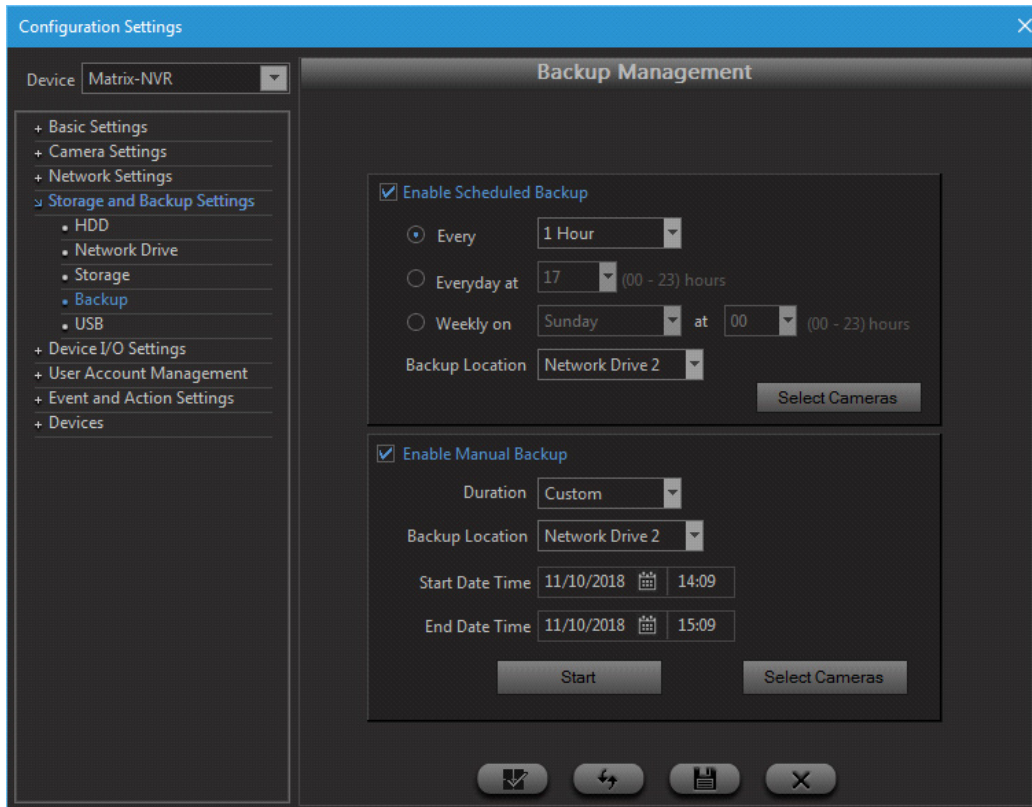

Backup can be taken in following two ways. For more information, click on the links below:

- [“Scheduled Backup”](#)
- [“Manual Backup”](#)

Scheduled Backup

This section enables the user to set the schedule for the automatic backup of recorded data. Check the **Enable Scheduled Backup** box to activate this functionality. The options available are as follows:

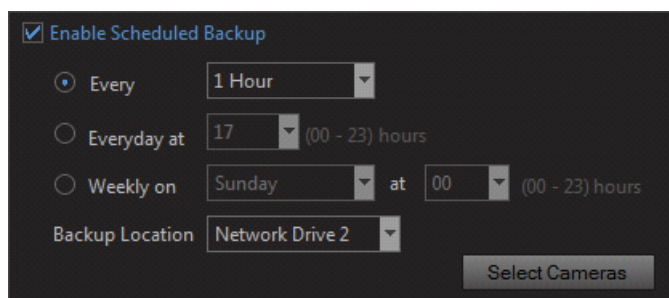

- **Every:** In the event of selecting this option the system performs an incremental backup every few hours as specified here.
- **Every Day:** On selecting this option the user needs to specify the time of hour in 24 hour format at which the incremental backup will be done.

- **Weekly:** If this option is selected, the user needs to specify the day of the week starting from 1 as Sunday, as well as the time of hour.
- **Backup Location:** Select the backup location from the list of drives and ftp servers in the drop-down list.
- **Select Cameras:** Click on this button to bring up the list of cameras in the pop up window. Select the check boxes against the cameras whose recordings are to be backed up. Click on OK when done.

Click on **Save** once done.

Manual Backup

The NVRX/NVRX P2/HVR also enables the user to take a manual backup as and when required. This section enables the user to configure the manual backup parameters. Check the **Enable Manual Backup** box to activate this functionality.

The screenshot displays a configuration window for manual backups. At the top, the 'Enable Manual Backup' checkbox is checked. Below it, the 'Duration' is set to 'Custom' via a dropdown menu. The 'Backup Location' is set to 'Network Drive 2' in another dropdown. The 'Start Date Time' is configured as '11/10/2018 14:09' and the 'End Date Time' is '11/10/2018 15:09'. At the bottom of the window, there are two buttons: 'Start' and 'Select Cameras'.

- **Duration:** Select the duration from the drop-down list, for which the manual backup is to be taken every time the manual backup option is selected.
- **Backup Location:** Select the backup location from the list of drives in the drop-down list.
- **Select Cameras:** Click on this button to bring up the list of cameras in the pop up window. Select the check boxes against the cameras whose recordings are to be backed up. Click on OK when done.
- **Start/End Date Time:** This option is enabled when **Duration** is selected as Custom. This functionality allows to configure user defined duration for backup rather than definite time. Specify the Start and End date-time for which you need to take the backup of the selected cameras.

Click on **Start/Save** to save the configurations and then click Start again to start the Manual Backup.

USB

The NVRX/NVRX P2/HVR enables the user to manage the connected USB drives for scheduled and manual backups. The port is available on the front face of the HVR to connect USB storage devices for scheduled and manual backups.

In order to access this functionality, click on the **Configuration** option from the left pane of the device client page. Select **Storage and Backup Settings** option and Click on **USB**. The USB Management page appears as shown below:

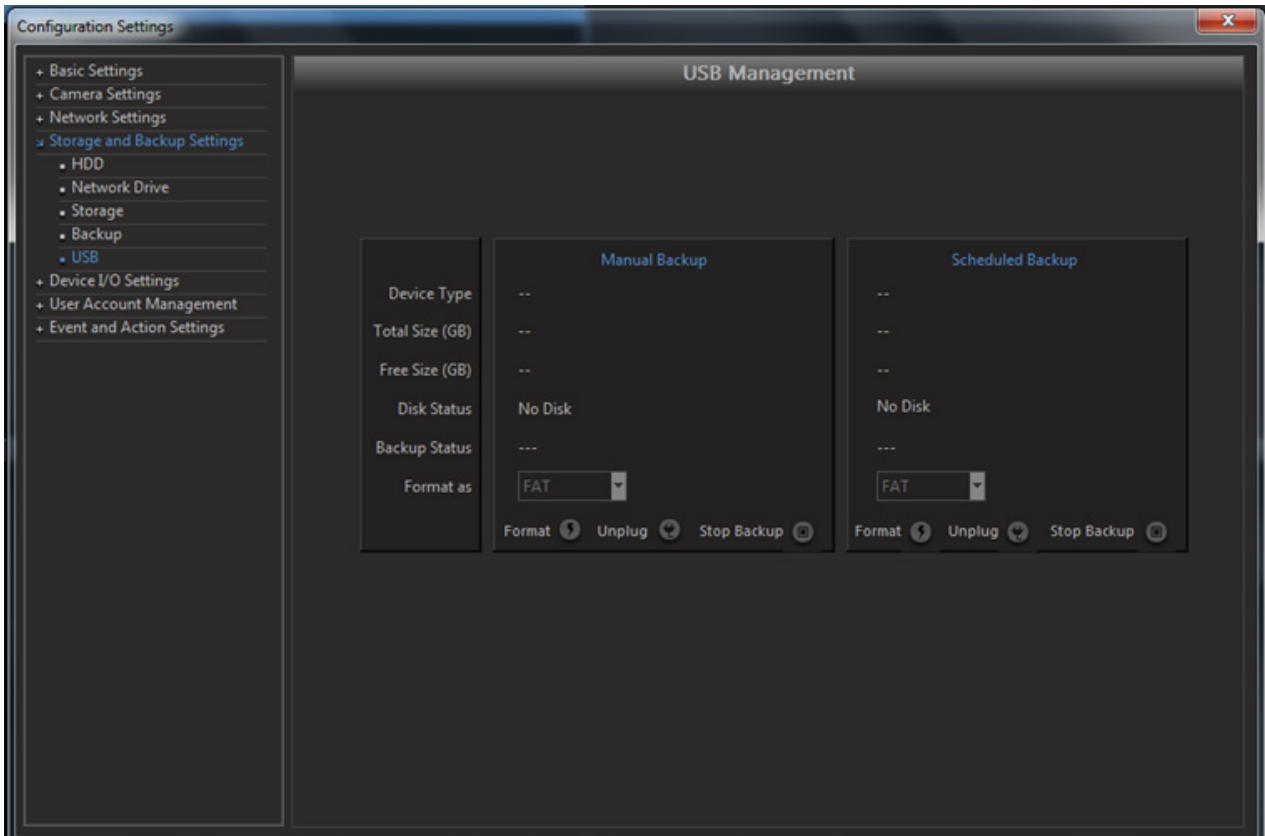

The page displays the details of the connected USB devices as well as the respective disk and backup statuses.

The system allows the user to format the connected USB in FAT (File Allocation Table) format by clicking on **Format** button as shown. However, this option needs to be used with discretion as the existing data on the USB disk will be erased when this process is initiated.

The **Unplug** button is provided to safely remove the USB drive from the SATATYA Device.

Stop Backup button enables the user to stop the scheduled or manual backup as and when required.

The Matrix SATATYA NVR Premium/NVRX/NVRX P2 (except NVRXS P2) and SATATYA HVR variants has an on-board capability of monitoring different input- output. The inputs can be connected to output ports of external alarm devices. The maximum distance of one line is 600m(2,000 feet) with a two conductor cable having a guage of AWG#22.



Device I/O Settings are not applicable to NVRXS P2 Series.

The number of IOs supported by different variants of SATATYA devices is shown below:

Device Input/ Outputs	NVR 64P/S	NVR 24P	NVR 8S	HVR 1624P	HVR 1624S	HVR 0824P	HVR 0824S	HVR 0408P	HVR 0408S
Max No. of Sensor Inputs supported	4	8	0	8	4	8	4	2	0
Max No. of Alarm Outputs supported	2	4	0	3	1	3	1	1	0

SATATYA NVRX/ NVRX P2 Series Variants	NVR0401XS P2 / NVR0801XS P2 / NVR1601XS P2	NVR0801X/ NVR1601X NVR0801X P2/ NVR1601X P2	NVR1602X/ NVR3202X NVR1602X P2/ NVR3202X P2	NVR3204X/ NVR6404X/ NVR3204X P2/ NVR6404X P2	NVR6408X/ NVR6408X P2/ NVR9608X P2
Max No. of Sensor Inputs supported	NA	2	2	2	2
Max No. of Alarm Outputs supported	NA	1	1	1	1

When the output relays are enabled, then they will be available to all events, which in turn can have the relay enabled or disabled, independently of each other.

[“Device Sensor Input Settings”](#)

[“Device Alarm Output Settings”](#)

Device Sensor Input Settings



Device Sensor Input Settings are not applicable to NVRXS P2 Series.

To configure the Input Settings, Click on **Configuration** option in the left pane of the device client page. Click on **Device I/O Settings** and select **Sensor Input**. The page appears as shown below.

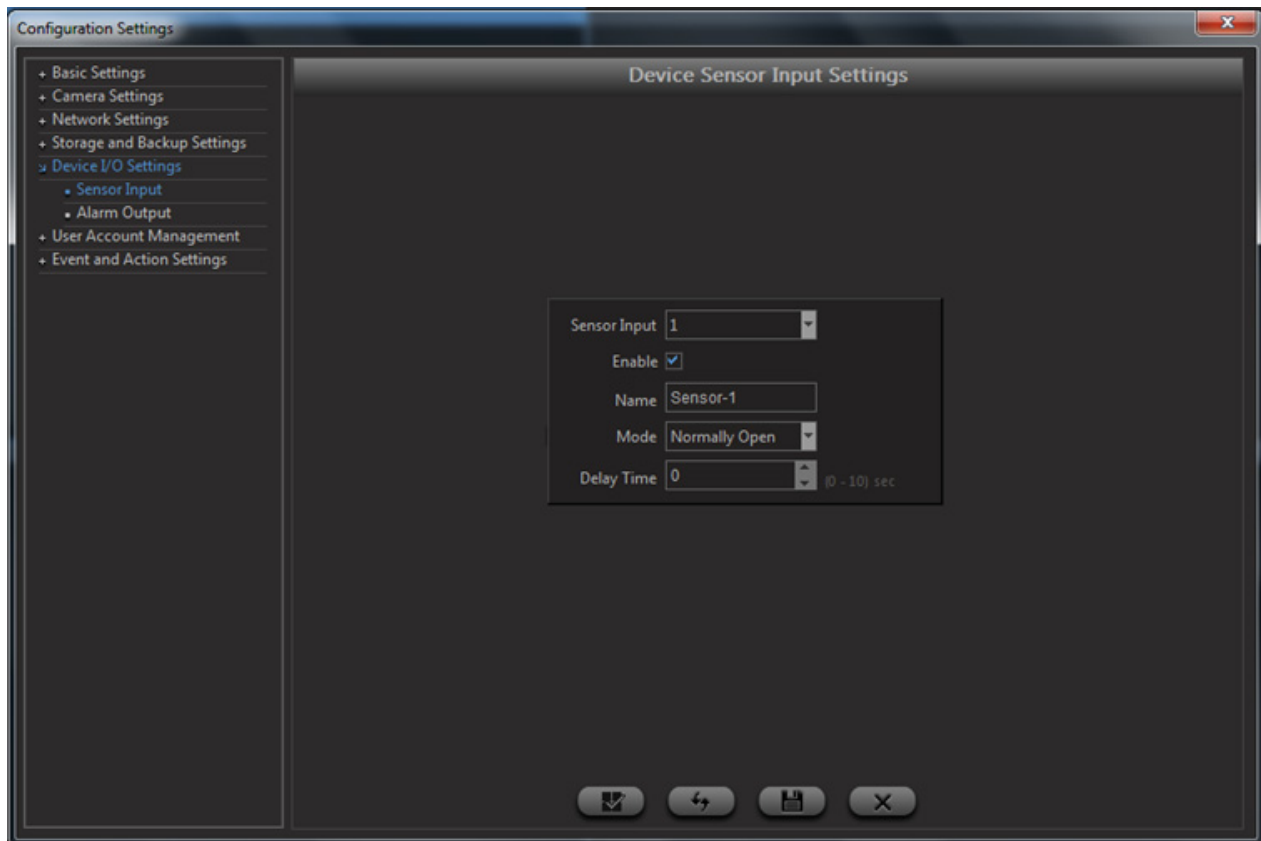

- Select the **Sensor Input** Number from the drop-down list.
- Click on the check box to **Enable** the Input.
- Specify a user friendly **Name** for the input for easy identification.
- The **Mode** Parameter allows selection of Normally Open (NO) or Normally Closed (NC) option based on the input required. This is dependent on the contacts of detector or alarm panel that is connected to this port.
- The **Delay Time** defines the minimum time an input must be in a given state i.e up or down, before being reported. For example, if a Normal state is changed to Alarm, the state must remain in Alarm for the specified seconds before an Alarm state is generated. Select the appropriate delay time in seconds for the selected input as per the site requirements.
- Click on **Save**  once done.

Device Alarm Output Settings



Device Alarm Output Settings are not applicable to NVRXS P2 Series.

To configure the Output Settings, Click on **Configuration** option in the left pane of the Device client page. Click on **Device I/O Settings** and select **Alarm Output**. The page appears as shown below.

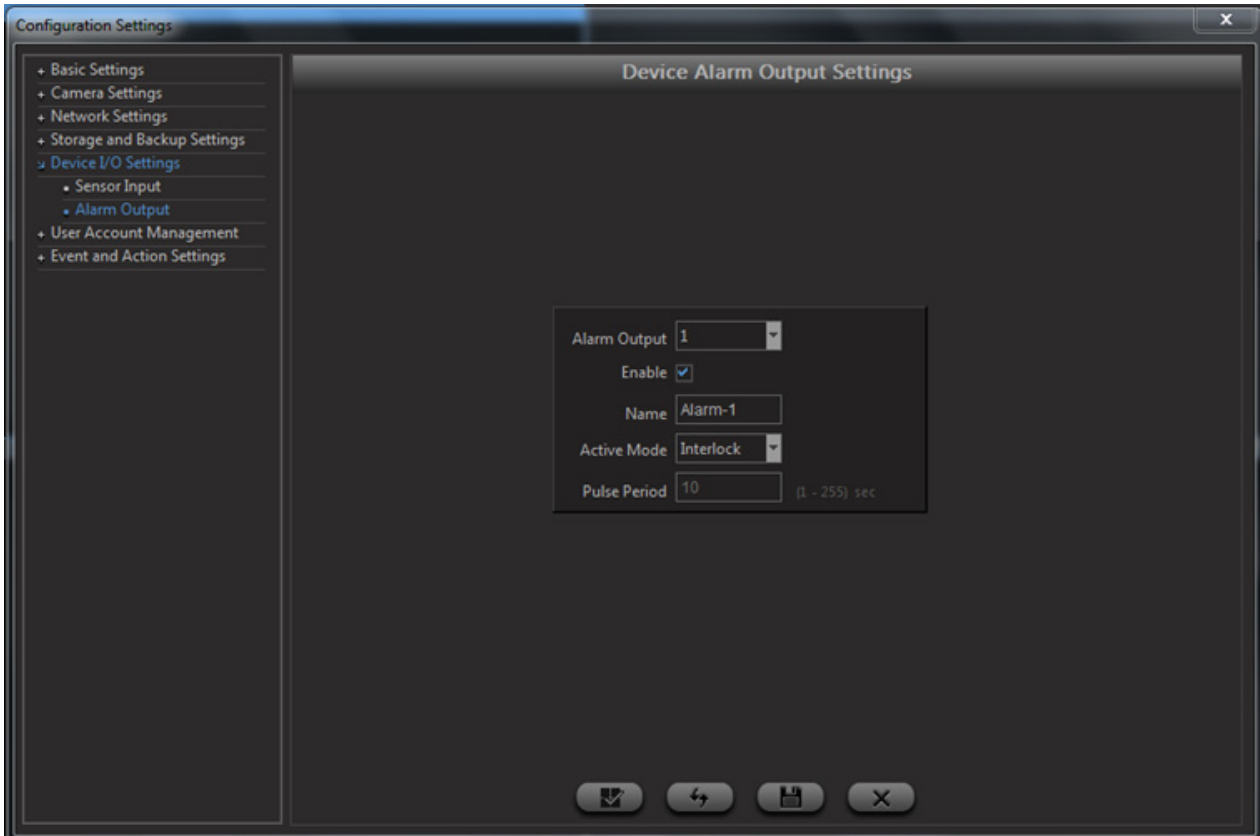

- Select the **Alarm Output** Number from the drop-down list.
- Click on the check box to **Enable** the Output.
- Specify a user friendly **Name** for the output for easy identification.
- The **Active Mode** Parameter has the following options:
 - **Interlock**: Once the Output Relay has been activated by the event, it will remain active as long as the event is active.
 - **Pulse**: The Output Relay will remain activated for the duration of the defined pulse time.
- In the Event of selecting the Pulse Mode, select the **Pulse Period** ranging from 1-255 seconds.
- Click on **Save**  once done.

The SATATYA device system supports the Event to Action linking feature to activate a predefined action based on an event. This option enables the administrator to define how an event will trigger certain actions as outputs. The events have been classified into the following categories:

“Camera Event”

- Motion Detection
- No Motion Detection
- View Tampering
- Camera Offline
- Camera Online
- Camera Sensors
- Recording Fail
- Trip Wire
- Object Intrusion
- Audio Exception
- Missing Object
- Suspicious Object
- Loitering
- Object Counting
- Recording Start



No Motion Detection in NVRX/NVRX P2 series is applicable only for Matrix camera's with firmware IPCamera_S05_FirmwareV02R12 and later.

No Motion in NVRX/NVRX P2 series is applicable for 2MP/ 5MP Ruggedized and 5MP All Color cameras only when the cameras are added via Camera Initiation or Brand and Model.

“Device Sensor”

- Sensor Active

“System”

- Manual Trigger
- On Boot
- Storage Alert
- Disk Volume Full
- Disk Fault
- Schedule Backup fail
- Firmware Upgrade

Camera Event

To configure the input settings, click on the **Configuration** option from the left pane of the device client page. Select the **Event and Action Settings** option and click on **Camera**. The Camera Event and Action settings page appears as shown below:

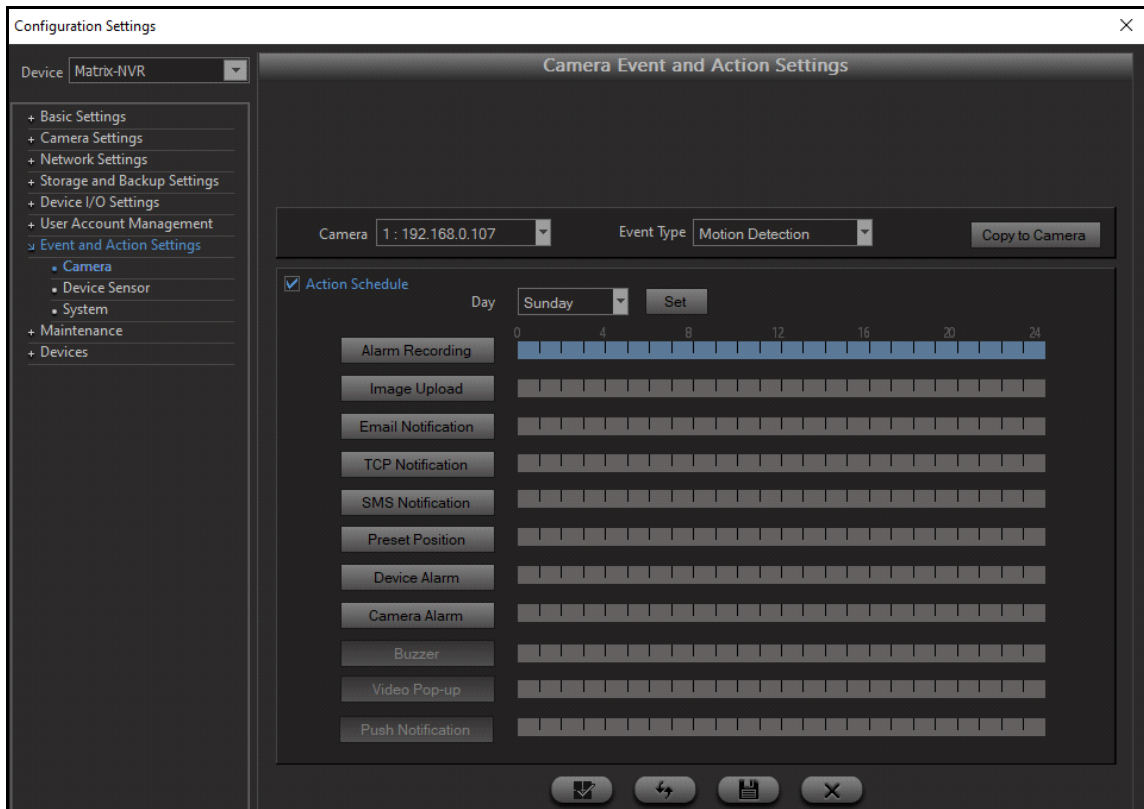

The user can now define a new Camera Event and Action linkage as follows.

Camera: Select the Camera from the drop-down list.

Event Type: Select the Event Type from the drop-down list.



Only supported Event types will be available for configuration depending on the selected camera brand and model.

For **Motion Detection** and **Camera Sensors** Event Types, the **Grand Stream Camera** gives notification on the configured HTTP Server when motion is activated / detected on the camera and when Alarm IN Status is changed to active on the camera.

To enable this Event and Action, check the box **Upload to HTTP Server** for Motion and Alarm Actions from the Camera web page as described below.

In the Camera web page, select the **Alarm Server** option. The Alarm HTTP Server Settings page appears. You have to do the following configurations.

Specify the **Server Name**. Eg: HVR

Specify the **URL** as Device IP Address: HTTP Port/alarm?alarm_type=%d&channel=%d

E.g.: 192.168.102.146:80/alarm?alarm_type=%d&channel=%d

Action Schedule:

Select this check box to enable the Action buttons. This option allows the administrator to configure the time periods during which these event-action linkings need to be activated.

Select the **Day** from the given options for which the action is to be scheduled. Click the **Set** button. The following page appears.

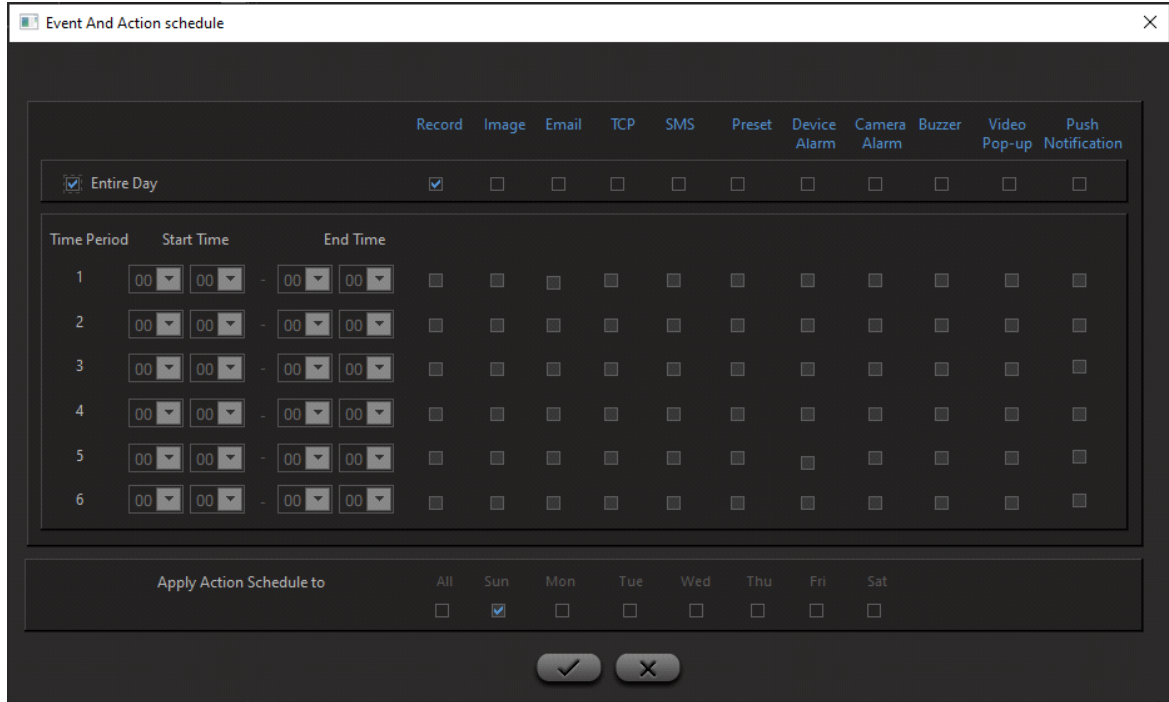

Time Period	Start Time	End Time	Record	Image	Email	TCP	SMS	Preset	Device Alarm	Camera Alarm	Buzzer	Video Pop-up	Push Notification
1	00:00	00:00	<input checked="" type="checkbox"/>	<input type="checkbox"/>	<input type="checkbox"/>	<input type="checkbox"/>	<input type="checkbox"/>	<input type="checkbox"/>	<input type="checkbox"/>	<input type="checkbox"/>	<input type="checkbox"/>	<input type="checkbox"/>	<input type="checkbox"/>
2	00:00	00:00	<input type="checkbox"/>	<input type="checkbox"/>	<input type="checkbox"/>	<input type="checkbox"/>	<input type="checkbox"/>	<input type="checkbox"/>	<input type="checkbox"/>	<input type="checkbox"/>	<input type="checkbox"/>	<input type="checkbox"/>	<input type="checkbox"/>
3	00:00	00:00	<input type="checkbox"/>	<input type="checkbox"/>	<input type="checkbox"/>	<input type="checkbox"/>	<input type="checkbox"/>	<input type="checkbox"/>	<input type="checkbox"/>	<input type="checkbox"/>	<input type="checkbox"/>	<input type="checkbox"/>	<input type="checkbox"/>
4	00:00	00:00	<input type="checkbox"/>	<input type="checkbox"/>	<input type="checkbox"/>	<input type="checkbox"/>	<input type="checkbox"/>	<input type="checkbox"/>	<input type="checkbox"/>	<input type="checkbox"/>	<input type="checkbox"/>	<input type="checkbox"/>	<input type="checkbox"/>
5	00:00	00:00	<input type="checkbox"/>	<input type="checkbox"/>	<input type="checkbox"/>	<input type="checkbox"/>	<input type="checkbox"/>	<input type="checkbox"/>	<input type="checkbox"/>	<input type="checkbox"/>	<input type="checkbox"/>	<input type="checkbox"/>	<input type="checkbox"/>
6	00:00	00:00	<input type="checkbox"/>	<input type="checkbox"/>	<input type="checkbox"/>	<input type="checkbox"/>	<input type="checkbox"/>	<input type="checkbox"/>	<input type="checkbox"/>	<input type="checkbox"/>	<input type="checkbox"/>	<input type="checkbox"/>	<input type="checkbox"/>

Entire Day: Select this check box if the event to action linking is to be activated throughout the day. Select the check boxes of the respective event that is to be linked with the action.

Time period: To specify the time period for linkage activation, select the start and the end time in the time period section and check the **Actions** box to enable the actions to be linked to the event during the specified time period.

Click on ALL or the selected days if the same schedule is to be applied to other days also.

Click on OK to save the settings and return to **Event & Action** home page.

Alarm Recording: Click on the Alarm Recording button to bring up the list of cameras. Check the boxes against the cameras whose video needs to be recorded. Click on the OK button to save the settings.

Image Upload: Click on the Image Upload button to bring up the list of cameras. Check the boxes against the cameras whose images are to be uploaded to the configured **FTP server**.

Email Notification: Click on the Email Notification button to configure an action to send an email to the specified email address using the configured **SMTP server**. Specify the email address in the **Mail Address** field. By default,

the system will send the name of the event in the subject line as well as the details of the event in the main message. However, the user can also define the subject as well as the message to be sent in the email.

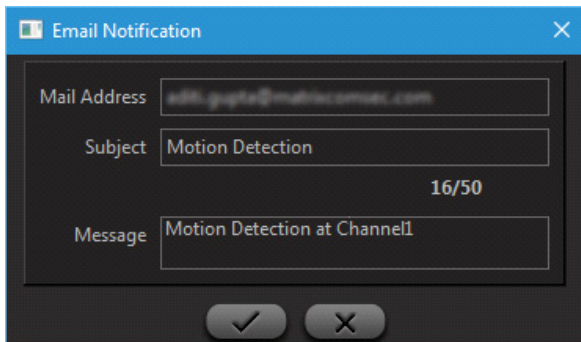

SMS Notification: This option requires a GSM modem to be connected to the serial port of the HVR and the modem settings configured from the **RS-232** option. On the occurrence of the event the system will send an SMS to the specified cell phones. The cellphone numbers are specified in the **Mobile No 1** and **Mobile No 2** fields. Click on the SMS Notification button to specify these parameters.

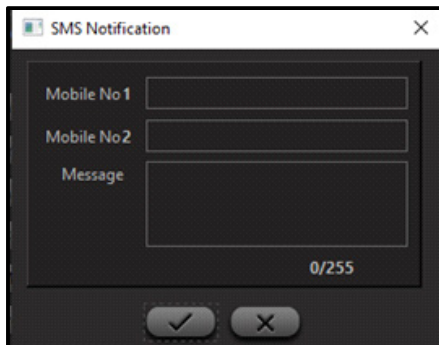

The Telecom Regulatory Authority of India (TRAI) have imposed SMS Scrubbing, that is every SMS content needs to be verified before it is delivered to the users. Hence it is mandatory for all businesses using SMS to register the SMS content template prior with their Service Provider. This is regulated to avoid spam, fake and fraudulent communication through SMS.

Once registered, the Service Provider will provide a Template ID against the registered SMS content.

*If you have selected **SMS Lane** as the Service Provider, make sure you enter the Template ID after the message content. Format: **&TemplateID=<value>***

TCP Notification: This option enables the administrator to configure an action to send a message to the specified tcp server as configured from the **Network** option as explained earlier. Click on the TCP Notification button and specify the message to be sent to the tcp server if required. This is only required if the default message as configured on the system is to be overridden.

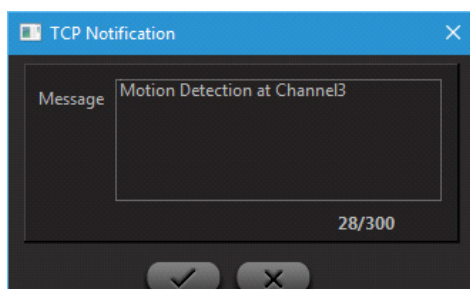

Go to PTZ Preset: This option enables the administrator to configure an action wherein the specified camera moves to the selected preset position. Click on the Preset Position button and select the Channel and the preset position from the drop-down lists. The Preset positions are configured from the **Preset Position** option under **Camera Settings** as described earlier.

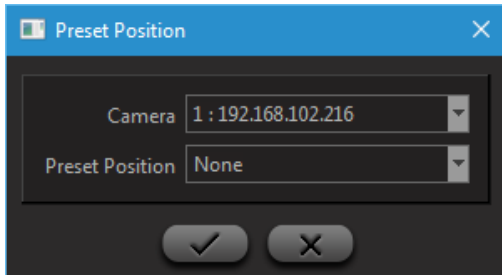

Device Alarm: This option enables the administrator to activate single or multiple relay ports on the occurrence of the specified event. Click on the Device Alarm button and check the boxes against the appropriate alarm ports which need to be activated. However, the relay ports need to be configured from the **Alarm Output** option before being assigned to an event.

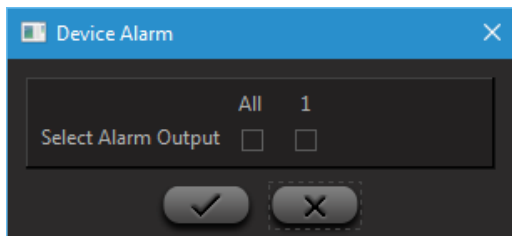

Device Alarm option is not applicable to NVRXS P2 Series.

Camera Alarm: This option enables the administrator to activate single or multiple relay ports at the cameras on the occurrence of the specified event. Click on the Camera Alarm button and select the camera from the drop-down list. Check the boxes against the appropriate alarm ports on the Camera which needs to be activated. However, the relay ports need to be configured from the **Alarm Output** option before being assigned to an event.

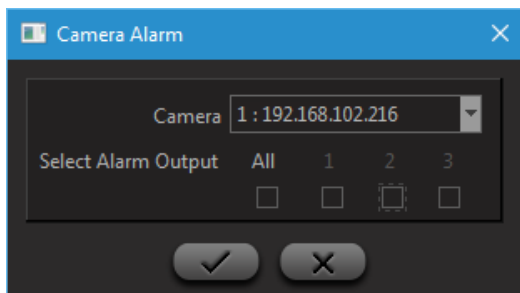

Buzzer: This option enables the administrator to play the buzzer on the occurrence of a configured event.

Video Pop-up: This option enables the administrator to open the video pop-up window and view the Live View of that respective camera on which the configured event occurs. This pop-up can be configured on the basis of user rights assigned from the ["User Account Management"](#) page.



*Video pop-up feature is available for Motion Detection/No Motion Detection, View Tampering, Trip Wire, Object Intrusion, Audio Exception, Camera Online and Loitering events.
It is restricted to 3x3 layout only. i.e. No layout other than 1x1, 2x2 and 3x3 will appear on event occurrence.*

Now, if a user having rights configures video pop-up action against the Motion/No Motion Detection event and if “Receive Video pop-up” option is enabled from Local Settings page, then the video pop-up window will appear on the occurrence of motion detection.



If camera audio is ON and if Video Pop-up appears, then after the pop-up gets closed, the camera audio should turn ON for the same camera.

Push Notification: This option enables the System Administrator to send Push Notification on the occurrence of a configured event. Push Notification will be sent by the NVRX/NVRX P2 to Firebase Cloud Messaging (FCM) which in turn will be sent it to the mobile client (SATATYA SIGHT) users. Make sure Push Notification is enabled for the user. For details refer to [“User Account Management”](#).

Device Sensor



Device Sensor settings are not applicable to NVRXS P2 Series.

To configure the input settings, Click on the **Configuration** option from the left pane of the device client page. Select **Event and Action Settings** and Click on **Device Sensor**. The Device Sensor Event and Action Settings page appear as shown below:

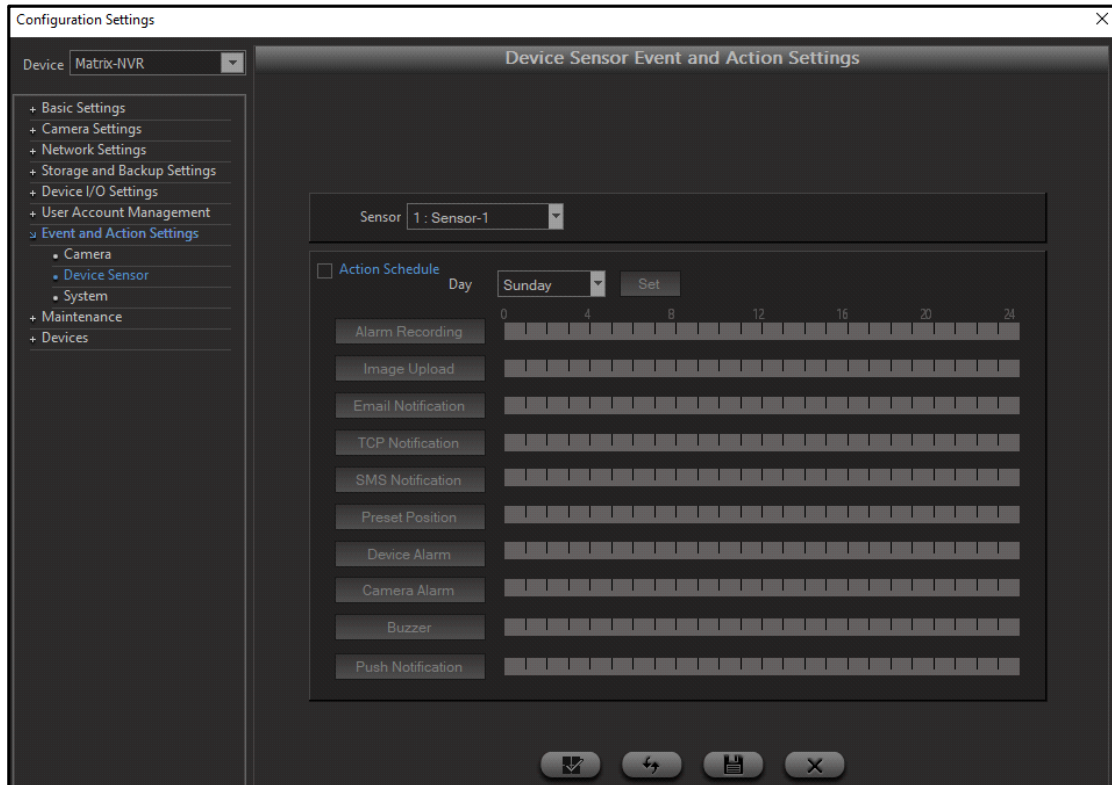

The user can now define a new Device Sensor Event and Action linkage as follows.

Sensor: Select the Sensor from the drop-down list. The number of ports available in the drop-down list will depend on the device variant.

Action Schedule: Select the check box to Enable the Action Schedule.

For more information on Action Schedule see [See "Action Schedule:" on page 335.](#) on **Camera** Event and Action Settings.

System

The administrator can configure the system **buzzer** on the NVR to be activated based on the occurrence of system events. Select this check box to enable the option as shown.

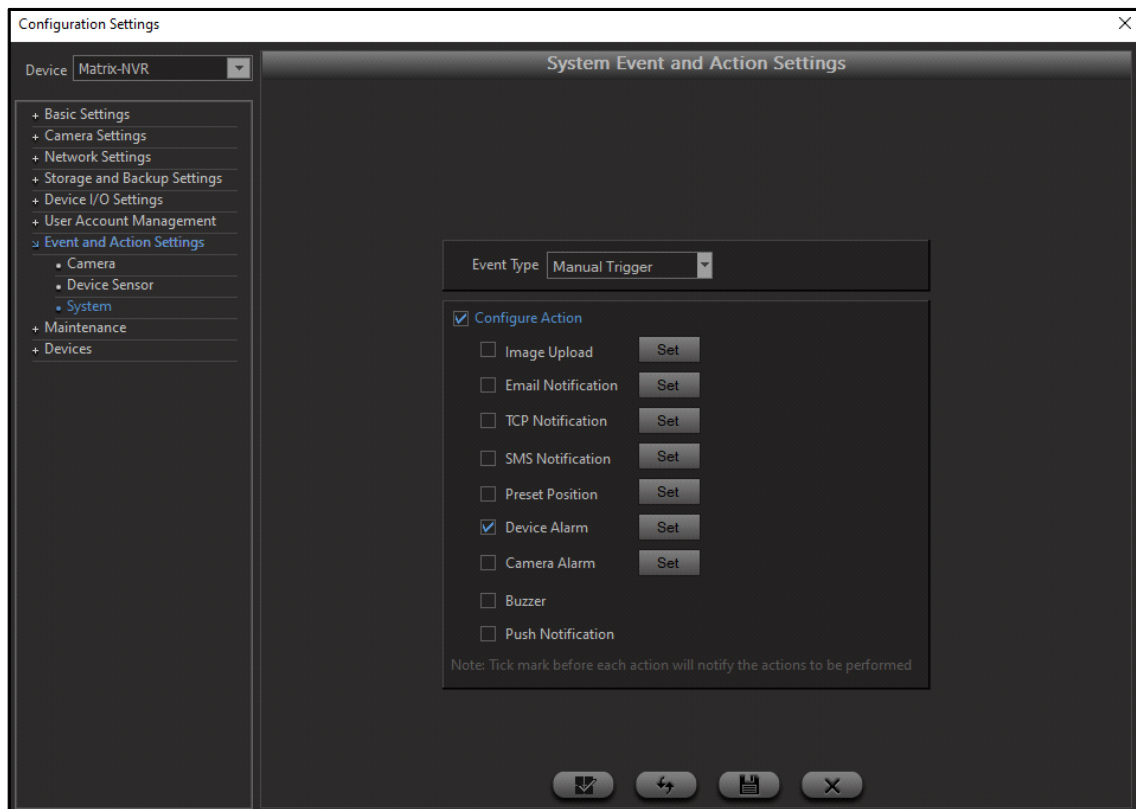

The user can now select an Event Type and Action linkage as follows.

Event Type: Select the Event Type from the drop-down list. The available options are:

- Manual Trigger
- On Boot
- Storage Alert
- Disk Volume Full
- Disk Fault
- Scheduled Backup Fail
- Firmware Upgrade

Configure Action: Select the check box to Enable the required Actions.

For setting different Actions, [See "Action Schedule:" on page 335.](#) on **Camera** Event and Action Settings.

Buzzer: Select the check box to enable the action of Buzzer. This option is available in Systems only.

Push Notification: Select the check box to enable the action of Push Notification. This option is available in Systems only.

As per the detection of the events and running actions, user will get the respective icons on the camera monitoring window, refer [See "Icons on Monitoring Window" on page 341.](#)

Icons on Monitoring Window

As per the detection of the events and running actions, user will get the respective icons on the camera monitoring window. Which are explained as below.



Audio On: It appears on the live view for the camera whose audio is currently enabled.



Audio Exception: It appears on the live view if the audio signals stop receiving suddenly by the device due to any reason.



Close: It displays on the camera caption. Click to close the live view and remove particular camera from the live view.



Loitering Detection: It appears when the Loitering Detection event is occurred. Loitering is often indicative of suspicious activity and some imminent act of violation.



Missing Object: It appears when any object goes missing from the missing object zone of the live view.



Motion Detection/No Motion Detection: It appears when the Motion Detection/No Motion Detection events occur. Motion Detection event enables the detection of any motion by an object or agent (such as people, vehicles etc.). No Motion Detection event is generated when no motion is detected for the configured duration.



No Motion Detection in NVRX/NVRX P2 series is applicable only for Matrix camera's with firmware IPCamera_S05_FirmwareV02R12 and later.

No Motion in NVRX/NVRX P2 series is applicable for 2MP/ 5MP Ruggedized and 5MP All Color cameras only when the cameras are added via Camera Initiation or Brand and Model.



No Video: It appears if the camera is not assigned yet and no video is available for the live view.



Decoding Error: In Local Client, It appears on the camera monitoring window for the particular cameras to indicate that the maximum decoding capacity for the live view or playback has been reached.



Camera Offline: It appears on the live view if the camera is offline.



Object Intrusion: It appears when the Object Intrusion event is occurred. The Intrusion Detection enables the detection of any new object or agent (such as people, vehicles etc.) entering or leaving an Intrusion Zone.





Other Error: It appears on the live view when the video is loss or the video stream is unable to be reached to the device from particular camera.



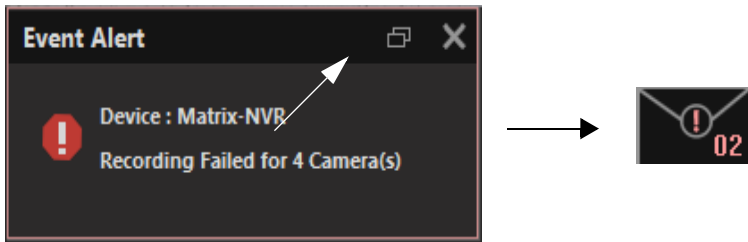

Recording: It will appear on the live view for the camera whose recording is started.

 **Recording Failed:** It appears when the recording is failed for the camera due to any reason. Whenever the recording gets failed, the pop-up will also appear on the monitoring window as shown below.





It shows the device and number of camera(s) for which the recording is failed. Click on the  icon to minimize the pop-up.

 **Suspicious Object Detection:** It appears if the suspicious object, vehicle or person is detected into the zone drawn on the live view.

 **Trip Wire:** It appears under the Trip Wire event occurrence if the Object or person crosses the line drawn on the live view.

 **View Tempering:** It appears under the View Tempering event occurrence if any attempts detected to impair the normal camera functioning.

 **Video Loss:** It appears at the Local Client whenever the Video Stream is stopped to be reached from the camera. At Device Client, **Video Loss**  symbol will appear on the live view in case of video loss.

Devices option allows the user to connect other SATATYA devices (maximum 20 devices) and establish reliable communication with a particular SATATYA device. The connection type available are IP Address, DDNS and Matrix DNS Server.



With models NVR0801X P2, NVR1601X P2 and NVR1602X P2, NVR3202X P2, NVR3204X P2, NVR6404X P2, NVR6408X P2, NVR9608X P2, NVR0401XS P2, NVR0801XS P2, NVR1601XS P2 the devices that can be connected are:

- *HVR: HVR1624P, HVR0824P, HVR0408P, HVR1624S, HVR0824S and/or HVR0408S. Vice-versa is not compatible for any device.*
- *NVR: NVR24P, NVR8S, NVR64S, NVR64P, NVR16S and/or NVR16H. Vice-versa is not compatible for any device.*
- *NVRX: NVR0801X, NVR1601X, NVR1602X, NVR3202X, NVR3204X, NVR6404X, NVR6408X and Vice-versa will be compatible only after you update these devices with Firmware Version V8R1.*
- *NVRX P2: NVR0801X P2, NVR1601X P2 and NVR1602X P2, NVR3202X P2, NVR3204X P2, NVR6404X P2, NVR6408X P2, NVR9608X P2 and Vice-versa will be compatible only after you update these devices with Firmware Version V8R4.*

To access this functionality, click on **Devices** option from the Configuration Settings. The page appears as shown below:

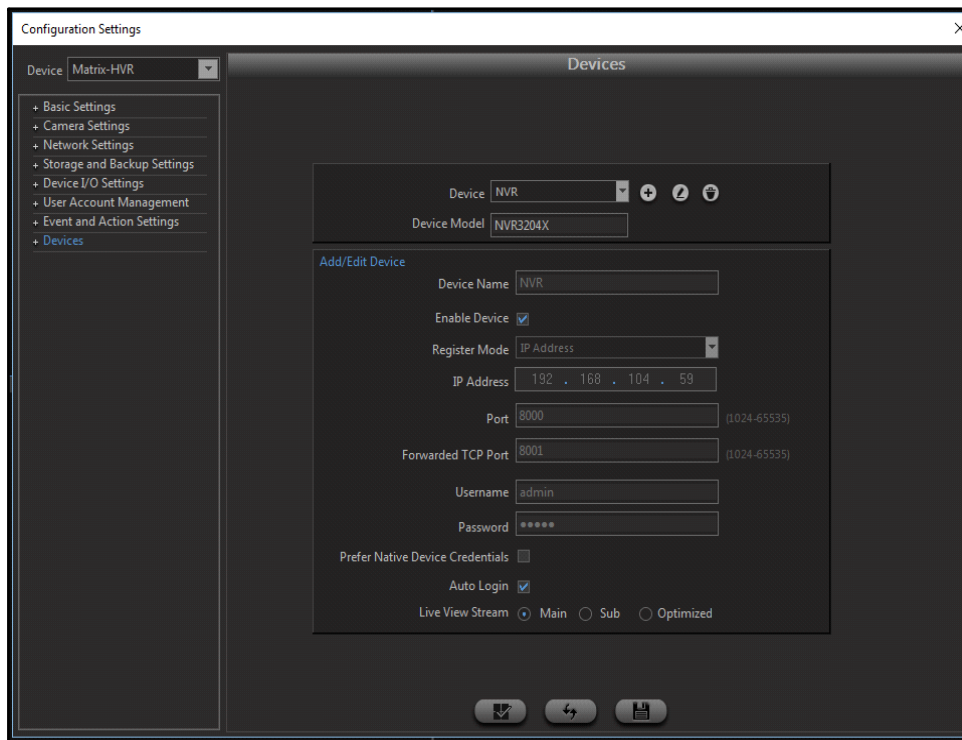

Device Model: Device model name of the added device will be displayed in this field.
For example: NVR3204X

Click on **Add Device** button to add a new device.

Device Name: Specify a user friendly **Device Name** such as HVR 24S.

Enable Device: Check the **Enable Device** box to activate the communication of HVR24S with the current device.

Register Mode: Select a **Register Mode** from the drop-down list to add the device. The options available are:

- **IP Address** - Specify the IP Address of the device to be added.
- **DDNS** - Specify the Host Name of the device to be added. For e.g.: matrixcosec.dyndns.info
- **Matrix DNS -MAC Address** - Specify the MAC Address of the device to be added.
- **Matrix DNS -Host Name** - Specify the Host Name of the device to be added.

Port: Specify the listening (forwarded TCP) port of the device to be added.

Forwarded TCP Port: Specify the listening port of the device located at the other network. Here, the forwarded port is used to connect the Network devices.

Example:

Consider the two Network Devices ND1 and ND2. The Network Device ND1 and the PC at which user has installed the Device Client are configured at the same network, while Network Device ND2 is configured at the other network.

Suppose user has done the following configuration in **Device Client -> Device Configuration -> Devices** for Network Devices ND1 and ND2.

ND1: Port = 8000, Forwarded TCP Port = 8001.

ND2: Port = 8000, Forwarded TCP Port = 8002.

SCENARIO 1: Connecting Network Device ND1 through the Device Client.

When the user tries to connect to the network device ND1 from the Device Client, the request goes to the normal **Port = 8000**. The network Device ND1 will be connected successfully as the both device client and ND1 are configured at the same network.

SCENARIO 2: Connecting Network Device ND2 through the Device Client.

When the user tries to connect to the network device ND2 from the Device Client, then the request first goes to the normal **Port = 8000**. After recognizing that the request has arrived from the other network, then the request goes to the **Forwarded TCP Port = 8002**. The Network Device ND2 will be connected successfully after being served by the Forwarded TCP Port.

Username and Password: Specify the **Username** and **Password** of the current device to which other devices are added.

Prefer Native Device Credentials: When this checkbox is enabled, then the username and password entered while adding the device will not be used on device client. It will always try to login on all cascaded devices with credentials which is provided for login on “my device”.

If any device is added through admin type user credential and if viewer user login is done on my device then on my device; only rights based camera listing will be there. On cascaded devices, all cameras will be listed as there will be admin login in cascaded device.

It is available in Local Client and Device Client.

Auto Login: Check the **Auto Login** box to activate the auto login into the device.

Live View Stream: Select the Main, Sub or Optimized option of stream for the live view. In optimized option, for 2x2 layout and above layouts substream will be displayed.

Click on the **Save** button to save the configuration.

Click on the **Set to default** button and below pop-up will appear on the screen.

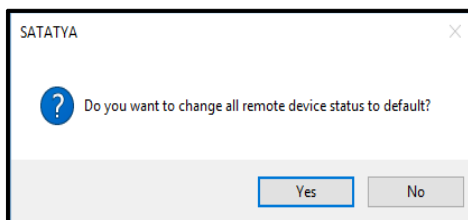

Click on the **Yes** button to reset all the configured remote devices with the default status and **No** button to cancel the reset.

User account creation and management involves creation of new login users as per the site requirement as well as managing the login user access rights and password. Users with the Administrator role have maximum rights and powers.

The **User Account Management** option allows the System Administrator to define additional users who will be using the SATATYA device as well as the device client application. Using this option, you may specify the System Rights and other information for the users based on their roles. In addition, you must provide each user a unique set of ID and Password. You can add maximum 128¹ users out of which 10 can be active at a time. You can also define a Password Policy which dictates how passwords can be set for each user account. For details, refer to ["Password Policy"](#).

The administrator can also delete an existing user or modify their settings.

User Account Management

You can configure these parameters from the Local as well as the Device Client.

In order to access this option in Local Client, click **Settings > User Account Management > User Account**. The User Account Management page appears:

In order to access this option in Device Client, click **Device Configuration > User Account Management > User Account**, the User Account Management page appears:

1. 128 Users for NVRX/NVRX P2 Series only. For other series it is 120 Users.

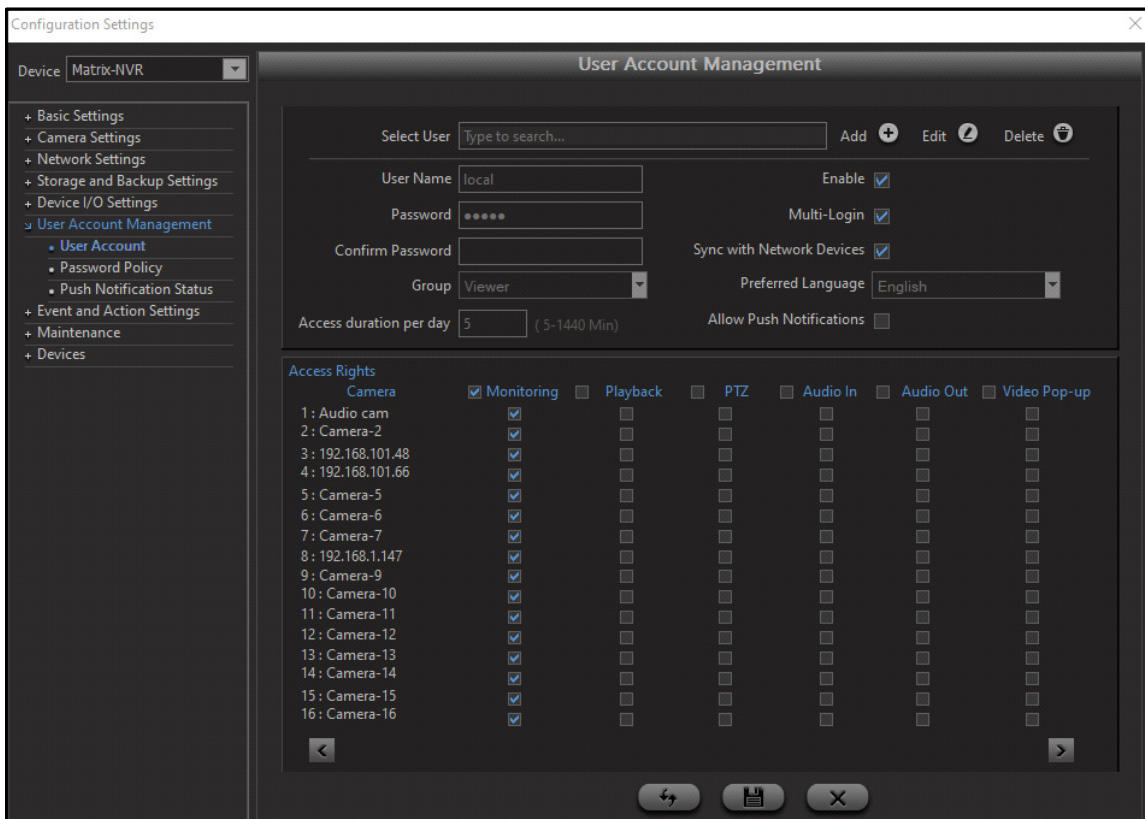

Click **Add** to add a new user and configure the following parameters:

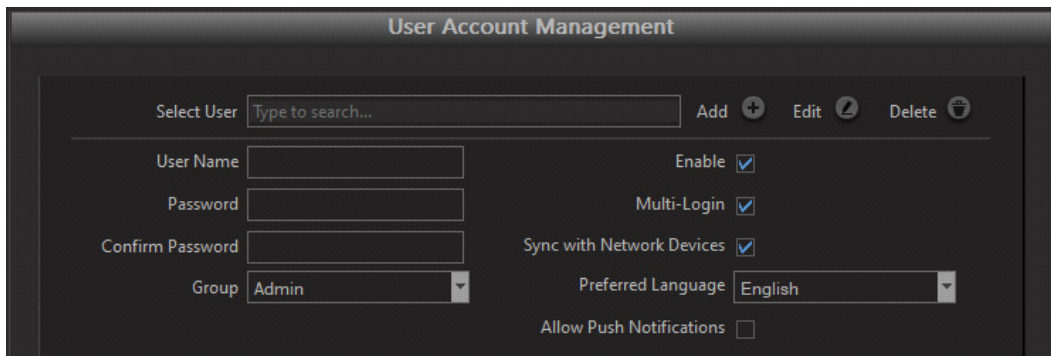

User Name: Specify the desired User Name.

Password: Specify the password for the user. The Password must have atleast:

- a minimum of 5 characters to a maximum of 16 characters.
- 1 Uppercase (A-Z)
- 1 Lowercase (a-z)
- 1 Number (0-9)
- 1 Character -_.,()[]:@!#\$%+&

Confirm Password: Re-enter the password in Confirm Password.

Enable: Select the Enable check box to activate the user.

Multi-Login: If you want multiple users to login using the same login credentials, select the Multi-Login check box.

Group: Click the drop-down list and assign one of the roles as per the user's access level. The options are **Admin**, **Operator** and **Viewer**. The Admin group has the maximum access rights while the Viewer group has the least access rights.



By default the users with user group 'Operator' and 'Viewer' will be disabled and can be enabled only by the users whose user group is 'Admin'

Preferred Language: This displays English.

Access Duration Per day: For users belonging to viewer group, access duration per day can be specified in the range of 5 to 1440 minutes.

Sync with Network Devices: When a new custom user is created with this check box enabled, and if the cascaded devices connected with MY DEVICE (native device) does not contain this user, then the same user which was created in MY DEVICE (native device) would be created in all the cascaded devices.

Through this flag the newly added users are automatically synced will all other cascaded devices to reduce overhead of creating same user in multiple cascaded devices.

Allow Push Notification: Android and Apple have removed the support of application functionalities that maintain a persistent connection to the Server (that is, if the application is in the background or in exit mode). The only way to reach these clients is Push Notification through Firebase Cloud Messaging (FCM) Server. The FCM acts as an intermediary between the message sender (SATATYA NVRX/NVRX P2) and client (SATATYA SIGHT).

For SATATYA NVRX/NVRX P2, if notifications for various events like Motion Detection, View Tampering, etc. need to be sent to the users on SATATYA SIGHT application, you must enable Push Notification, in the SATATYA NVRX/NVRX P2 as well as SATATYA SIGHT.

Push Notifications can be configured as actions against desired events. For details refer to "[Event and Action Settings](#)". If the SATATYA SIGHT application is in the exit mode or in the background and you want the mobile client users to receive notifications — camera, sensors, system events — then select the Allow Push Notification check box. The notification will be displayed to the users.



Make sure you have enabled Push Notification in the SATATYA SIGHT application. Push Notification is supported in SATATYA SIGHT from firmware version V3R7.4 and onwards.

You can view the list of mobile clients for which the Push Notifications are being sent by SATATYA NVRX/NVRX P2 in the **Push Notification Status** Table. For details refer to "[Push Notification Status](#)".

Access Rights: This section enables the administrator to edit the access rights to various functionalities of the NVRX/NVRX P2/HVR for users belonging to the **Viewer** group. The user access rights for each camera can be edited for the following functionalities:

- Monitoring
- Playback
- PTZ Control
- Audio In
- Audio Out
- Video Pop-Up

Click on **Save** to save the configuration.

The administrator can also edit or delete any existing user.

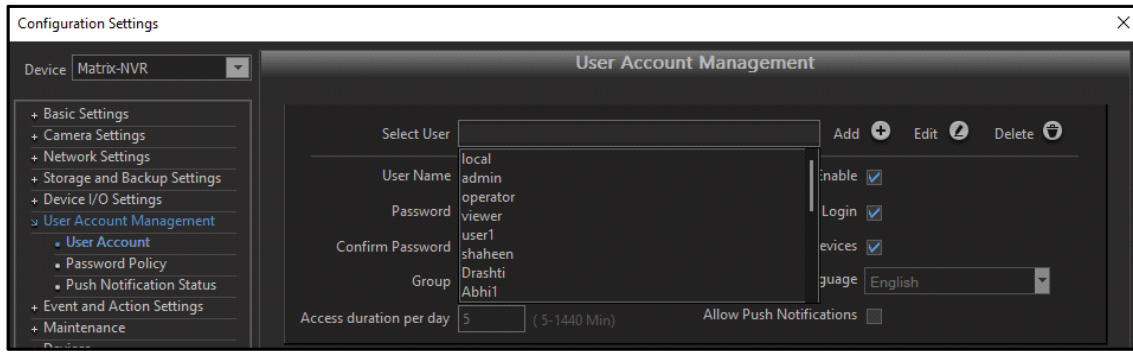

The users created in the system will be displayed in the list when your cursor placed in the **Select User** field.

The newly created admin user can edit the rights of users created under admin, operator and viewer group. The default admin, operator and local user's cannot be edited.

Edit:

In **Select User**, type the initial letters, the list of matching names appears. Click the desired name to select. Click on **Edit** button to modify the user account settings.

Delete:

In **Select User**, type the initial letters, the list of matching names appears. Click the desired name to select. Click on **Delete** button to delete the selected user.

Example:

A new admin user "Sheetal" is created, operator user "Swati" is created and Viewer user "Aditi" is created by the admin. When Sheetal logs into the Device Client, then she can edit the rights of Swati and Aditi.

In Local Client, the users created in the system will be displayed in the drop-down list in Select User field as shown below.

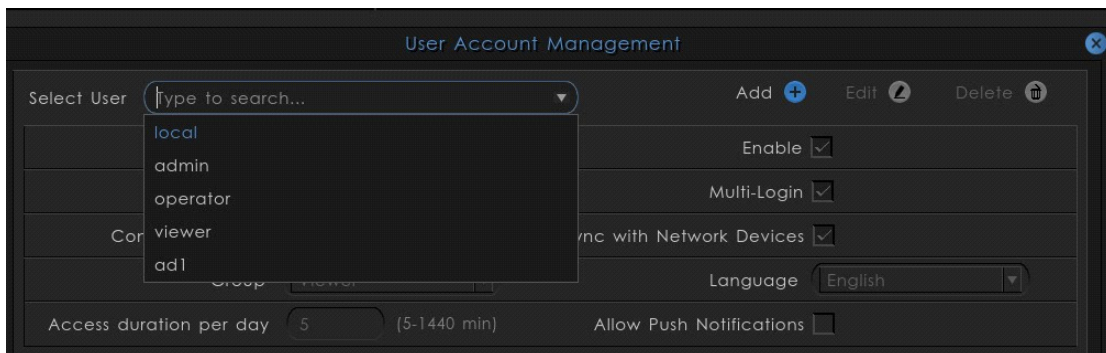

Password Policy

The password policy feature imposes restrictions on how a password can be set for any user account, be it for default users (admin, operator, viewer), or any other custom SATATYA user. It controls three aspects of a password - Password Strength, Password Validity and Account Lockout Policy. The policy will be applicable for new user creation and for first-time user login on device initiation.

In order to access this option in Local Client, click **Settings > User Account Management > Password Policy**. The Password Policy page appears.

In order to access this option in Device Client, **Device Configuration > User Account Management > Password Policy**. The Password Policy page appears.

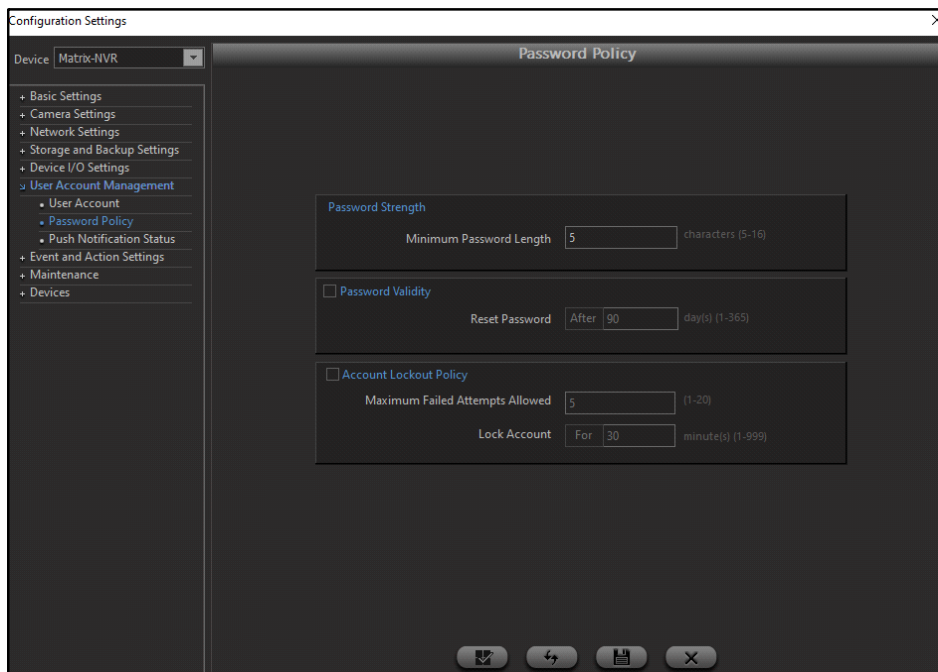

Password Strength

Set a minimum character count required for setting a new password. The allowed range is 5-16.

The Password must have atleast:

- a minimum of 5 characters to a maximum of 16 characters.
- 1 Uppercase (A-Z)
- 1 Lowercase (a-z)
- 1 Number (0-9)
- 1 Character - _.,()[]:@!#\$*+/\

Password Validity

Enable this option to set a validity period for all passwords. On enabling this option, the password will expire after a period (days) defined in the **Reset Password** field and a new password must be set by user.

Account Lockout Policy

Enable this option for a user account to get automatically locked when a certain number of failed login attempts have been made after the expiry of account lockout time. Specify the **Maximum Failed Attempts Allowed**

(applicable for NVRX/NVRX P2 Series but in older version it is Maximum Invalid Login Attempts Allowed). The attempts range is 1-20. Define a **Lock Account For** period in (minutes) after which account login should be restored for the locked account. The time duration range is 1-999 minutes.



If user enters incorrect User Name / Password and Account Lockout Policy is enabled, then remaining attempts will also be displayed along with the existing message. Hence, message displayed will be "Incorrect User Name or Password. You have <n> login attempt(s) left."

Save the settings to apply the Password Policy.

Push Notification Status

The mobile clients receiving the Push Notification are displayed in this table. This table will display a maximum of upto 10 registered clients. If new clients need to be registered an existing entry needs to be deleted by the System Administrator.

The screenshot shows a web interface titled 'Configuration Settings' with a sidebar menu on the left. The main content area is titled 'Push Notification Status' and contains a table with the following data:

User Name	Model Name	Inactivity Timer (HHH:MM)	Delete
admin	Manthan's iPhone	197:34	

The following details are displayed for each mobile client:

- **User Name:** The name of the user who is logged into the mobile client.
- **Model Name:** The Model Name of the mobile client.
- **Inactivity Timer:** After the timer duration expires and if the user has not logged into the mobile client, then Push Notifications will be stopped and the respective client entry will be removed from the status page. This timer will be reset every-time the user logs into the mobile client. Timer Duration is fixed as 10 days.
- **Delete:** The System Administrator can delete any entry if Push Notifications are no longer required for that mobile client user.



*The entry in the table will be removed automatically, if the **Allow Push Notification** check box is disabled or if the user is disabled/deleted/blocked by the System Administrator.*

Monitoring and Control Options

The purpose and utilities of Matrix SATATYA device is shown in the below figure. The SATATYA device provides the following functionalities of monitoring and control of the device. These options enable the user to:

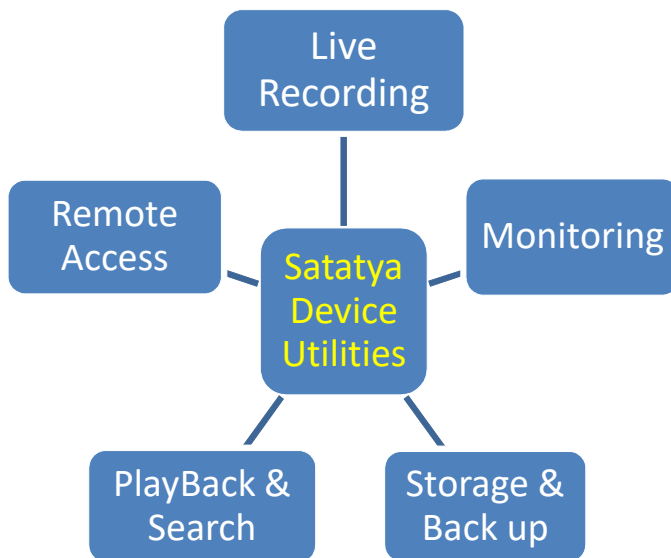

The SATATYA device provides the following functionalities for the monitoring and control of the device. These options enable the user to:

- Search and view recorded video [See “Search and Playback” on page 153.](#)
- Control Alarm outputs and Manual Trigger [See “Manage” on page 138.](#)
- Control user access [See “Users” on page 138.](#)
- Control system operations like
 - System Shutdown
 - System Restart
 - Default configuration [See “Manage” on page 138.](#)
- Upgrade Firmware [See “Firmware Upgrade:” on page 207.](#) and [See “Firmware Management” on page 355.](#)
- Modify Password [See “Change Password” on page 201.](#)

- View event logs and health status of the device [See “Event Log” on page 192.](#)

Firmware Management

NVRX/NVRX P2 supports Auto Firmware Upgrade through the FTP. Using Auto Firmware Upgrade, NVRX can automatically download the firmware files stored at a central location and upgrade its firmware. The files can be stored on the Matrix FTP Server or any other third party FTP Server.



Auto Firmware Upgrade is supported from Firmware Version V7R13 and later.

To configure Auto Firmware Upgrade parameters,

- Click on the **Configuration** option from the left pane of the Device Client.
- Click **Maintenance**. Click **Firmware Management**. The Auto Firmware Upgrade page opens.

The screenshot shows a web-based configuration interface for a Matrix-NVR device. The main window is titled "Configuration Settings" and has a sub-header "Firmware Management". On the left, there is a navigation menu with options: Basic Settings, Camera Settings, Network Settings, Storage and Backup Settings, Device I/O Settings, User Account Management, Event and Action Settings, Maintenance (expanded), and Devices. Under "Maintenance", "Firmware Management" is selected. The main content area contains the following settings:

Auto Firmware Upgrade	Never
Daily At (HH:MM)	00:00
FTP Server	MATRIX COMSEC
Address	
Port	21 (1 - 65535)
User Name	
Password	
Firmware Path	
Check for Update	<input type="checkbox"/>

- Select the desired **Auto Firmware Upgrade** option — Never, Notify Only, Download and Upgrade.
Default: Never.

- **Never:** The NVRX/NVRX P2 will never initiate the Auto Firmware Upgrade process.
- **Notify Only:** When the firmware zip file of a version higher than the current NVRX/NVRX P2 firmware version is present on the FTP, then an event will be generated.

When a new firmware is available, then the event will be logged in the Event Log against which the user can configure the desired action. For details, refer to [“Event and Action Settings”](#).

- **Download and Upgrade:** The NVRX/NVRX P2 will check for new firmware files at regular intervals (as configured in Daily At) on the FTP Server. If upgraded files are available these will be downloaded and the upgrade process will be initiated automatically.

To set the schedule, that is, the time interval after which the NVRX/NVRX P2 needs to check for new firmware files on the FTP Server, you must configure the time interval in **Daily At**.



The system will reboot after Download and Upgrade of the firmware.

- Select the desired **FTP Server** — MATRIX COMSEC, Custom.

If you select **MATRIX COMSEC**, you do not have to configure the parameters —Address, Port, User Name, Password, Firmware Path. These will appear blank but will be fetched automatically.

If you select **Custom**, you must configure the parameters —Address, Port, User Name, Password, Firmware Path

- Configure the FTP Server **Address** on which the firmware files are stored. NVRX will fetch the firmware for upgrade from here.
- Configure the **Port**. This is the FTP listening port on which FTP communication will be done.
- Configure the **User Name** of the FTP Server.
- Configure the **Password** of the FTP Server.
- Configure the **Firmware Path**, that is, the folder path on the FTP Server where the Version-wise firmware folders are stored within which the respective firmware zip files are present. You must enter the Path till the folder wherein the Version-wise folders are present.

For example: ftp://192.168.101.222:5000/Firmwares/NVR/16Channel/V7R12/web/
NVR1602X_32X_64X_firmware_V07R08.zip is the FTP URL then, you must configure Firmwares/NVR/
16Channel as the Firmware Path.

- Click **Check for Update**, to manually check for firmware updates available on the FTP Server.
- Click **Submit** to save.

You can upgrade the firmware manually also, if you have the firmware files in your PC. For details refer to **Firmware Upgrade** in [“Manage”](#).

Appendix

Glossary of Terms

Active X: Active X is Microsoft software component technology which facilitates sharing of information between differing applications. Video recorders (NVRs and HVRs) utilize Active X to remotely view security cameras online.

Compression: Compression Techniques are used in Digital CCTV to reduce the file sizes of recorded video images. Typical compression formats used for video are: MJPEG, MPEG-4, H.264 & H.265.

PAL (Phase Alternate Line): This is the Video encoding standard for Europe.

NTSC (National Television Systems Committee): A committee that worked with the FCC in formulating standards for the present day United States color television system and is their video encoding standard.

Iris: This parameter enables the user to set the degree to which the aperture opens or closes to maintain proper light levels on the security camera sensor. Works similar to the iris on the human eye to adjust for light.

Zoom: To enlarge or reduce, on a continuously variable basis, the size of a televised image primarily by varying lens focal length.

Resolution: The number of horizontal lines a system can display.
Digital Resolution (e.g. 720 x 576)

720 = number of points in each row that make up the picture

576 = number of rows

Frame Rate: The quality of a Digital Surveillance Systems is often determined by the Total Frame Rate it can record at. The higher the Frame Rate, the higher the quality of recording and the more Real Time your CCTV recording will be - Real Time recording for 1 camera is 25 Frames Per Second (PAL).

Motion Detection: Recording method for digital surveillance systems. When someone walks in front of a camera, the pixels change and the SATATYA device defines this as motion. The surveillance system will then record these images to the hard disk. This is a popular recording setup as every event recorded is actually motion driven as opposed to a static image if the system was set to record 'round-the-clock'.

Sensitivity: The sensitivity of a camera is configured on the digital surveillance system. Motion Detection based recording uses relies on the sensitivity of the cameras to trigger recording.

Hue: Corresponds to colors such as red, blue, etcetera.

Saturation: In color, the degree to which a color is diluted with white light or is pure. The vividness of a color, described by such terms as bright, deep, pastel, pale, etc. Saturation is directly related to the amplitude of the chrominance signal.

Brightness: The attribute of visual perception in accordance with which an area appear to emit more of less light. (Luminance is the recommended name for the photo-electric quantity which has also been called brightness.)

Contrast: The range of light to dark values in a picture or the ratio between the maximum and minimum brightness values.

RAID Concept

RAID level is used to improve the performance of the system by load sharing and providing fault tolerance and redundancy. This maintains redundant data which can be used to restore data on the event of disk failure.

SATATYA HDD Management allows the HDD modes according to the way of storing the data in multiple physical disks interfaced to the NVR. Each physical disk is considered as an Individual memory slot; and the data is filled up in succession.

SATATYA Devices supports High reliability RAID 0, RAID 1, RAID 5 and RAID 10 HDD modes. In which, SATATYA NVR and HVR variants supports RAID 0 and RAID 1 HDD modes. SATATYA NVRX/NVRX P2 Series variants supports RAID 0, RAID 1, RAID 5 and RAID 10 (only in NVRX Series variants) HDD modes. For the detailed explanations of supported RAID types, [See "Types of HDD Modes in NVRX" on page 359.](#)

Among all the NVRX/NVRX P2 variants, there is difference in number of available SATA interfaces and Ethernet ports. So based on SATA interfaces, RAID level can be configured. For the RAID creation using different combinations of HDD. [See "RAID Creation in NVRX series variants" on page 363.](#)

Types of HDD Modes in NVRX

Single Disk Volume

In Single Disk Volume each physical disk is considered as an Individual memory slot; and the data is filled up in succession.

Total Logical Volume Calculation

If Volume of HDD1= V1, then Logical Volume= V1
Suppose HDD1= 2TB, then Logical Volume= 2TB

RAID 0

Minimum 2 HDDs are required. The data is striped in the 2 blocks. Thus, the data stored in disk 1 will not be available in disk 2. Hence, there is no redundant data available.

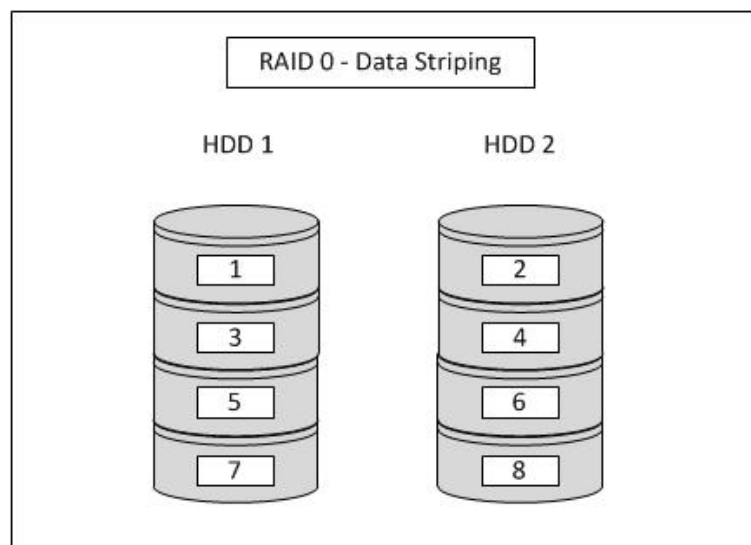

Total Logical Volume Calculation

If Volume of HDD1= V1 and HDD2= V2,
then Logical Volume= V1+V2

Suppose HDD1= 2TB and HDD2= 1TB, then Logical Volume= 2TB + 1TB= 3TB

RAID 1

Minimum 2 HDDs are required. The data in the 2 blocks is mirrored. Thus, the data stored in disk 2 will be the replica of the data available in disk 1. Hence, redundant data is available.

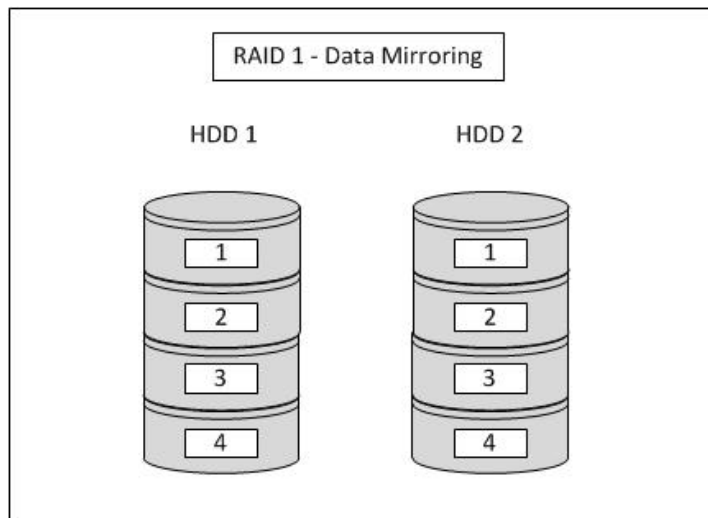

Total Logical Volume Calculation

If Volume of HDD1= V1 and HDD2= V2,
then Logical Volume= Lowest of the two disks

Suppose HDD1= 2TB and HDD2= 1TB, then Logical Volume= 1TB

RAID 5

Minimum 3 HDDs are required. It stores data as well as parity in the disks. The data is striped and parity is randomly distributed in the disks. Parity is written into one disk by XOR-ing the data of other disks and this parity is stored randomly in different disks.

Now, if any one hard disk gets failed, then from the Parity bit which is the result of XOR-ing the data of the other two disks, data can be retrieved easily by performing the reverse operation.

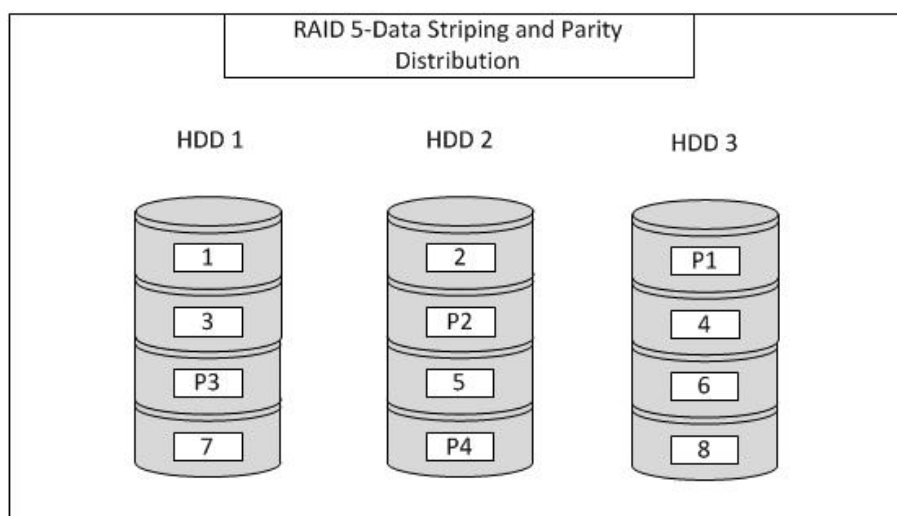

Total Logical Volume Calculation

If Volume of HDD1= V1, HDD2= V2 and HDD3= V3,
then Logical Volume= (Number of HDDs -1) X Minimum Disk Size.

Suppose HDD1= 2TB, HDD2= 1TB and HDD3= 1TB, then Logical Volume= (3-1)X1= 2TB

RAID 10

Minimum 4 HDDs are required. It is the combination of RAID 1 and RAID 0.

Out of the four disks, the first two disks HDD1 and HDD2 will contain mirrored data. The second two disks, HDD3 and HDD4 will also contain mirrored data.

The combination of (HDD1 and HDD2) and (HDD3 and HDD4) will contain striped data as shown in the screen below.

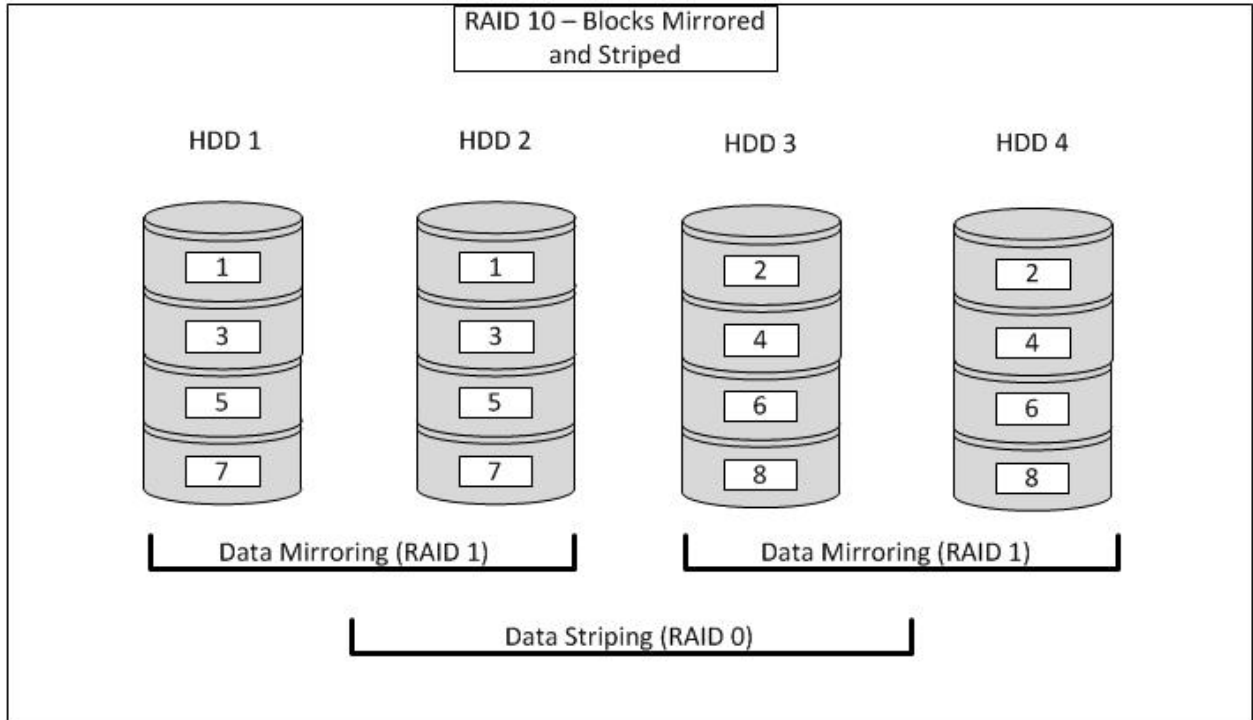

Total Logical Volume Calculation

If Volume of HDD1= V1, HDD2= V2 HDD3= V3 and HDD4= V4, then Logical Volume= V1+V3 or V1+V2.

(Combinations can be any, [See “RAID Creation in NVRX series variants” on page 363.](#))

Suppose HDD1= 2TB, HDD2= 1TB and HDD3= 1TB and HDD4=2TB.

Now, HDD1 and HDD2 will contain mirrored data (RAID 1), so Logical Volume= 1TB (Lowest of HDD1 and HDD2)

Similarly, HDD3 and HD4 will contain mirrored data (RAID 1), so Logical Volume= 1TB (Lowest of HDD3 and HDD4)

Now, the output of both the combination will contain stripped data (RAID 0). So Total Logical Volume= 1TB + 1TB= 2TB

RAID Creation in NVRX series variants

As explained above, in SATATYA NVRX Series variants RAID level can be configured based on the number of SATA interfaces available in the particular variant. The table below indicates the HDD modes/RAID levels and the pairing of drives in each NVRX series variant.



While RAID creation, if the pairing of drives is not done as defined in the table below, then the message displaying incorrect HDD combination will appear. So it is recommended to refer this table prior RAID creation.

NVRX Series Variants	Number of SATA Interfaces Available	HDD Modes Supported	Pairing of Drives based on connected HDD
NVR0401XS P2/ NVR0801XS P2/ NVR1601XS P2	1	Single Disk Volume	1
NVR0801X/NVR0801X P2	1	Single Disk Volume	1
NVR1601X/NVR1601X P2	1	Single Disk Volume	1
NVR1602X/NVR3202X/ NVR1602X P2/ NVR3202X P2	2	Single Disk Volume	1
		RAID 0	1-2
		RAID 1	1-2
NVR3204X/NVR6404X/ NVR3204X P2/NVR6404X P2	4	Single Disk Volume	1
		RAID 0	1-2 and 3-4
		RAID 1	1-2 and 3-4
		RAID 5 Volume A	1-2-3 and 1-2-3-4
NVR6408X/ NVR6408X P2/ NVR9608X P2	8	Single Disk Volume	1
		RAID 0	1-2, 3-4, 5-6 and 7-8
		RAID 1	1-2, 3-4, 5-6 and 7-8
		RAID 5 Volume A	1-2-3, 1-2-3-4, 5-6-7 or 5-6-7-8
		RAID 10 Volume A	1-2-3-4 and 5-6-7-8

Technical Specification

For NVR technical details, refer to the following:

- [“NVRXS P2 Series Variants”](#)
- [“NVRX/NVRX P2 Series Variants”](#)
- [“Other NVR Variants”](#)

For HVR technical details, refer to the following:

- [“Hybrid Video Recorders”](#)

Network Video Recorders

NVRXS P2 Series Variants

Functions	NVR1601XS P2	NVR0801XS P2	NVR0401XS P2
Video			
Input	16 IP Channels	08 IP Channels	04 IP Channels
HDMI Resolution	1280 x 720 1920 x 1080 3840 x 2160	1280 x 720 1920 x 1080 3840 x 2160	1280 x 720 1920 x 1080 3840 x 2160
Compression Algorithm	H.265/H.264/Motion JPEG	H.265/H.264/Motion JPEG	H.265/H.264/Motion JPEG
Audio			
Audio Compression	G.711 μ	G.711 μ	G.711 μ
Throughput			
Downlink Throughput	180 Mbps ad higher	180 Mbps ad higher	180 Mbps ad higher
Uplink Throughput	180 Mbps ad higher	180 Mbps ad higher	180 Mbps ad higher
Display			
Snapshot	Yes (JPEG)	Yes (JPEG)	Yes (JPEG)
Storage Interface			
RAID	Single Disk	Single Disk	Single Disk
SATA Interface	1 SATA III (10TB per port)	1 SATA III (10TB per port)	1 SATA III (10TB per port)
Interface			
Network Interface	1 Port x Ethernet (RJ-45) 10/100/1000Mbps	1 Port x Ethernet (RJ-45) 10/100/1000Mbps	1 Port x Ethernet (RJ-45) 10/100/1000Mbps
USB	2 Ports (1x USB 3.0, 1x USB2.0)	2 Ports (1x USB 3.0, 1x USB2.0)	2 Ports (1x USB 3.0, 1x USB2.0)
Environment Condition			
Operating Temperature	0°C to +45°C (32°F to 113°F)	00°C to +45°C (32°F to 113°F)	0°C to +45°C (32°F to 113°F)

Humidity Range	5% to 95% RH Non-Condensing	5% to 95% RH Non-Condensing	5% to 95% RH Non-Condensing
Electrical and Mechanical			
Power Input	12V DC, 2A	12V DC, 2A	12V DC, 2A
Power Consumption (Typical - without Hard Disk)	3 to 4.5 W	3 to 4.5 W	3 to 4.5 W
Dimension (LXBXH) in mm	266 X 157 X 44 in mm	266 X 157 X 44 in mm	266 X 157 X 44 in mm
Weight (without HDD)	490 gms	490 gms	490 gms
<i>Note: Specifications are subject to change without notice.</i>			

NVRX/NVRX P2 Series Variants

Functions	NVR0801X/ NVR1601X/ NVR0801X P2/ NVR1601X P2	NVR1602X/ NVR3202X/ NVR1602X P2/ NVR3202X P2	NVR3204X/ NVR6404X/ NVR3204X P2/ NVR6404X P2	NVR6408X/ NVR6408X P2/ NVR9608X P2
Compression Algorithm	H.265, H.264, MPEG-4, M-JPEG (as supported by the connected camera)	H.265, H.264/ MPEG4/ Motion JPEG (as supported by the connected camera)	H.265, H.264, MPEG-4, M-JPEG (as supported by the connected camera)	H.265, H.264, MPEG-4, M-JPEG (as supported by the connected camera)
Audio Compression	G.711	G.711	G.711	G.711
Snapshot Format	JPEG	JPEG	JPEG	JPEG
Video				
HDMI Resolution	1280 x 720 1920 x 1080 3840 x 2160	1280 x 720 1920 x 1080 3840 x 2160	1280 x 720 1920 x 1080 3840 x 2160	1280 x 720 1920 x 1080 3840 x 2160
IP Camera Input	NVR0801X/ NVR0801X P2 =8 IP Channels NVR1601X/ NVR1601X P2=16 IP Channels	NVR1602X/ NVR1602X P2=16 IP Channels NVR3202X/ NVR3202X P2=32 IP Channels	NVR3204X/ NVR3204X P2=32 IP Channels NVR6404X/ NVR6404X P2=64 IP Channels	NVR6408X/ NVR6408X P2 = 64 IP Channels NVR9608X P2 = 96 IP Channels
Audio				
Audio Input	1 Channel, RCA port	1 Channel, RCA port	1 Channel, RCA port	1 Channel, RCA port
Audio Output	1 Channel, RCA port	1 Channel, RCA port	1 Channel, RCA port	1 Channel, RCA port
Interface				
Communication interface	1 RJ45 10/100/1000 Mbps adaptive Ethernet Interface	2 RJ45 10/100/1000 Mbps Ethernet port	2 RJ45 10/100/1000 Mbps adaptive Ethernet Interface	2 RJ45 10/100/1000 Mbps adaptive Ethernet Interface
USB Interface	USB 3.0= 1 USB 2.0= 2	USB 3.0= 1 USB 2.0= 2	USB 3.0= 1 USB 2.0= 2	USB 3.0= 1 USB 2.0= 2

Functions	NVR0801X/ NVR1601X/ NVR0801X P2/ NVR1601X P2	NVR1602X/ NVR3202X/ NVR1602X P2/ NVR3202X P2	NVR3204X/ NVR6404X/ NVR3204X P2/ NVR6404X P2	NVR6408X/ NVR6408X P2/ NVR9608X P2
Throughput				
Down-link Speed (for NVRX) (for NVRX P2)	256 Mbps 180 Mbps and higher (for NVRX P2 8 and 16 channels only) 512 Mbps (for NVRX P2 96 channels only)			
Up-link Speed (for NVRX) (for NVRX P2)	256 Mbps 180 Mbps and higher (for NVRX P2 8 and 16 channels only) 512 Mbps (for NVRX P2 96 channels only)			
Storage				
SATA Interface	1 SATA interfaces, can support 1 SATA HDD with max capacity of 10 TB.	2 SATA interfaces, can support 2 SATA HDD with max capacity of 10 TB.	4 SATA interfaces, can support 4 SATA HDD each with max capacity of 10 TB.	8 SATA interfaces, can support 8 SATA HDD each with max capacity of 10 TB.
Sensor IN/Alarm OP				
Alarm Inputs	2 Sensor inputs	2 Sensor inputs	2 Sensor inputs	2 Sensor inputs
Alarm outputs	1 Alarm output	1 Alarm output	1 Alarm output	1 Alarm output
General				
Power Supply	12 VDC, 5 A	12 VDC, 5 A	100-240 VAC, 50-60Hz	100-240 VAC, 50-60Hz
RAID	Single Disk	RAID 0, RAID 1, Single Disk	RAID 0, RAID 1, RAID 5, RAID 10, Single Disk	RAID 0, RAID 1, RAID 5, RAID 10, Single Disk
Power Consumption (Typical - without Hard Disk)	20W 5W for NVR0801X P2/NVR1601X P2 (without Hard Disk)	30W 6W for NVR1602X P2 (without Hard Disk)	50W	65W
Operating temperatures	0°C to +50°C (32°F to 122°F)	0°C to +50°C (32°F to 122°F)	0°C to +50°C (32°F to 122°F)	0°C to +50°C (32°F to 122°F)
Humidity Range	5% to 95% RH Non-Condensing	5% to 95% RH Non-Condensing	5% to 95% RH Non-Condensing	5% to 95% RH Non-Condensing
Dimensions (W x H x D) (in mm)	320mm(without clamp) X 45.85mm X 195.5mm	425.5mm (without clamp) X 54.6mm X 196mm	442mm (without clamp) X 105.75mm X 240.45mm	442mm (without clamp) X 105.75mm X 355.45mm
Weight (without HDD)	1.2 Kgs	1.5 Kgs	3.7 Kgs	5.5 Kgs
<i>Note: Specifications are subject to change without notice.</i>				

Other NVR Variants

Functions	SATATYA NVR8S	SATATYA NVR16S	SATATYA NVR24P	SATATYA NVR16H	SATATYA NVR64P/S
Compression Algorithm	H.264, MPEG-4, M-JPEG (as supported by the connected camera)	H.264/MPEG4/ Motion JPEG (as supported by the connected camera)	H.264, MPEG-4, M-JPEG (as supported by the connected camera)	H.264/MPEG4/ Motion JPEG (as supported by the connected camera)	H.264, MPEG-4, M-JPEG (as supported by the connected camera)
Audio Compression	G.711	G.711	G.711	G.711	G.711
Snapshot Format	JPEG	JPEG	JPEG	JPEG	JPEG
Video					
VGA Video Output	One 15 pin D(5+5+5) connector	One 15 pin D(5+5+5) connector	One 15 pin D(5+5+5) connector	One 15 pin D(5+5+5) connector	One 15 pin D(5+5+5) connector
VGA and HDMI Resolution	1024 x 768 (XVGA) 1280 x 1024 (SXVGA) 1280 x 720 (HDMI - 720p) 1920 x 1080 (HDMI - 1080p)	1024 x 768 (XVGA) 1280 x 1024 (SXVGA) 1280 x 720 (HDMI - 720p) 1920 x 1080 (HDMI - 1080p)	1024 x 768 (XVGA) 1280 x 1024 (SXVGA) 1280 x 720 (HDMI - 720p) 1920 x 1080 (HDMI - 1080p)	1024 x 768 (XVGA) 1280 x 1024 (SXVGA) 1280 x 720 (HDMI - 720p) 1920 x 1080 (HDMI - 1080p)	1024 x 768 (XVGA) 1280 x 1024 (SXVGA) 1280 x 720 (HDMI - 720p) 1920 x 1080 (HDMI - 1080p)
IP Camera Input	8 Channels	24 Channels	24 Channels	24 Channels	64 Channels
Audio					
Audio Input	1 Channel, RCA port	N.A.	1 Channel, RCA port	2 Channel, RCA port and 16 Input DB-15 connector	N.A.
Audio Output	1 Channel, RCA port	N.A.	1 Channel, RCA port	1 Channel, RCA port	N.A.
Interface					
Communication interface	1 RJ45 10/100 Mbps adaptive Ethernet Interface	1 RJ45 10/100 Mbps Ethernet port and 1 RS485 Interface available for PTZ Control (RS485 Not In Use)	1 RJ45 10/100 Mbps adaptive Ethernet Interface 1 RS485 Interface available from terminal block connector (RS485 Not In Use)	2 RJ45 Gigabit Ethernet port and 1 RS485 Interface available for PTZ Control (RS485 Not In Use)	2 RJ45 Gigabit Ethernet port
USB Interface	2 USB 2.0 Interface	2 USB 2.0 Interface	4 USB 2.0 Interface	4 USB 2.0 Interface	4 USB 2.0 Interface
Throughput					

Functions	SATATYA NVR8S	SATATYA NVR16S	SATATYA NVR24P	SATATYA NVR16H	SATATYA NVR64P/S
Down-link Speed	16 Mbps	48 Mbps	48 Mbps	48 Mbps	NVR64S= 128 Mbps NVR64P= 256 Mbps
Up-link Speed	32 Mbps	96 Mbps	96 Mbps	96 Mbps	NVR64S= 128 Mbps NVR64P= 128 Mbps
Storage					
SATA Interface	1 SATA interfaces, can support 1 SATA HDD with max capacity of 6 TB.	1 SATA interfaces, can support 1 SATA HDD with max capacity of 6 TB.	2 SATA interfaces, can support 2 SATA HDD each with max capacity of 6 TB.	4 SATA interfaces, can support max capacity of 6TB each.	4 SATA interfaces, can support max capacity of 6TB each.
Sensor IN/Alarm OP					
Alarm Inputs	2 Sensor inputs	4 Sensor inputs	8 Sensor inputs	8 Sensor inputs	4 Sensor inputs
Relay outputs	NA	1 Alarm outputs	4 Alarm outputs	3 Alarm outputs	2 Alarm outputs
General					
Power Supply	12 VDC, 2 A	12 VDC, 5 A	12 VDC, 5 A	12 VDC, 7 A	100-265 VAC, 47-63Hz
RAID	NA	NA	Normal, RAID 0, RAID 1	RAID 0,RAID1	Normal, RAID 0, RAID 1
Power Consumption (as per adapter ratings)	<24W (with 1 HDD)	<60W (with 1 HDD)	<60W (with 2 HDDs)	<84W (with 4 HDD)	<100W (with 4 HDDs)
Operating temperatures	0 deg C to 50 deg C	0 deg C to 50 deg C	0 deg C to 50 deg C	0 deg C to 50 deg C	0 deg C to 50 deg C
Humidity Range	5% to 95% RH Non condensing	10% to 95% RH Non condensing	5% to 95% RH Non condensing	10% to 95% RH Non condensing	0% to 90% RH Non condensing
Dimensions(W x D x H)	220.00mm x 123.5mm x 65.00mm	360.00mm x 153.5mm x 48.45mm	445.50mm x 196.25mm x 50.00mm	445.00mm x 274.00mm x 79.60mm	445.00mm x 268.5mm x 74.6mm
Weight (without HDD)	0.90 Kgs	1.4 Kgs	2.94 Kgs	3.6 Kgs	5.750 Kgs
<i>Note: Specifications are subject to change without notice.</i>					

Hybrid Video Recorders

Functions	SATATYA HVR1624P	SATATYA HVR1624S	SATATYA HVR0824P	SATATYA HVR0824S	SATATYA HVR0408P	SATATYA HVR0408S
Video Compression	H 264/MPEG4/ Motion JPEG(as supported by the connected camera)					

Functions	SATATYA HVR1624P	SATATYA HVR1624S	SATATYA HVR0824P	SATATYA HVR0824S	SATATYA HVR0408P	SATATYA HVR0408S
Audio Compression	Analog G.711 and IP Input: G.711, G.726, G.729 and AAC (depends on the camera)					
Snapshot Format	JPEG					
Playback/ Record speed (fps)	480 fps @ D1	480 fps @ WD1	480 fps @ D1	480 fps @ WD1	120 fps @ D1	120 fps @ D1
Video						
VGA and HDMI Resolution	1024 x 768 (XVGA), 1280 x 1024 (SXVGA), 1280 x 720 (HDMI - 720p), 1920 x 1080 (HDMI - 1080p)					
VGA Video Output	One 15 pin D(5+5+5) connector					
Frame Rate (per Analog Channel)	25fps@D1	25 fps @WD1	25 fps @D1	25 fps @WD1	25 fps @D1	25 fps @D1
Default Analog Video Input	16 Channels (BNC)	16 Channels (BNC)	8 Channels (BNC)	8 Channels (BNC)	4 Channels (BNC)	4 Channels (BNC)
Default IP Input	24 Channels	24 Channels	16 Channels	16 Channels	8 Channels	8 Channels
Audio						
Audio Input	2 Channel, RCA port and 16 Input DB-15 connector	2 Channel, RCA port	2 Channel, RCA port and 8 Input DB-15 connector	2 Channel, RCA port	2 Channel, RCA port	NA
Audio Output	1 Channel, RCA port	1 Channel, RCA port	1 Channel, RCA port	1 Channel, RCA port	1 Channel, RCA port	NA
Interface						
Communication interface	2 RJ45 Gigabit Ethernet port and 1 RS485 Interface available for PTZ Control	1 RJ45 10/100 Mbps Ethernet port and 1 RS485 Interface available for PTZ Control	2 RJ45 Gigabit Ethernet port and 1 RS485 Interface available for PTZ Control	1 RJ45 10/100 Mbps Ethernet port and 1 RS485 Interface available for PTZ Control	1 RJ45 100 Mbps adaptive Ethernet port and 1 RS485 Interface available for PTZ Control	1 RJ45 100 Mbps adaptive Ethernet port

Functions	SATATYA HVR1624P	SATATYA HVR1624S	SATATYA HVR0824P	SATATYA HVR0824S	SATATYA HVR0408P	SATATYA HVR0408S
USB Interface	Left USB- Mouse Right USB- Mouse, Manual Backup Upper USB- Mouse, Dongle Lower USB- Mouse, Scheduled Backup	Upper USB- Mouse, Dongle, Manual Backup Lower USB- Mouse, Scheduled Backup	Left USB- Mouse Right USB- Mouse, Manual Backup Upper USB- Mouse, Dongle Lower USB- Mouse, Scheduled Backup	Upper USB- Mouse, Dongle, Manual Backup Lower USB- Mouse, Scheduled Backup	Upper USB- Mouse, Dongle, Manual Backup Lower USB- Mouse, Scheduled Backup	Upper USB- Mouse, Dongle, Manual Backup Lower USB- Mouse, Scheduled Backup
Throughput						
Down-link Speed	48 Mbps	48 Mbps	48 Mbps	48 Mbps	16 Mbps	16 Mbps
Up-link Speed	96Mbps	96 Mbps	96 Mbps	96 Mbps	32 Mbps	32 Mbps
Storage						
SATA Interface	4 SATA interfaces, can support max capacity of 6TB each.	1 SATA interfaces, can support max capacity of 6TB	4 SATA interfaces, can support max capacity of 6TB each.	1 SATA interfaces, can support max capacity of 6TB	1 SATA interfaces, can support max capacity of 6TB.	1 SATA interfaces, can support max capacity of 6TB.
Network Drive	Support 2 network drive					
General						
Power Supply	12 VDC, 5A	12 VDC, 3.3A	12VDC,5A	12 VDC, 3.3A	12 VDC, 2A	12 VDC, 2A
RAID	RAID 0,RAID1	NA	RAID 0, RAID1	NA	NA	NA
Operating temperatures	0 deg C to 50 deg C(32F to 122F)					
Humidity Range	10% to 95% RH Non condensing					
Dimensions (W x D x H)	445.00mm x 274.00mm x 79.60mm	360.00mm x 153.5mm x 48.45mm	445.00mm x 274.00mm x 79.60mm	360.00mm x 153.5mm x 48.45mm	220.00mm x 123.50mm x 65.00mm	220.00mm x 123.5mm x 65.00mm
Weight (without HDD)	3.7 Kgs	1.45 Kgs	3.6 Kgs	1.40 Kgs	0.95 Kgs	0.90 Kgs
<i>Note: Specifications are subject to change without notice.</i>						

Disposal of Products/Components after End-Of-Life

Main components of Matrix products are given below:

- **Soldered Boards:** At the end-of-life of the product, the soldered boards must be disposed through e-waste recyclers. If there is any legal obligation for disposal, you must check with the local authorities to locate approved e-waste recyclers in your area. It is recommended not to dispose-off soldered boards along with other waste or municipal solid waste.
- **Batteries:** At the end-of-life of the product, batteries must be disposed through battery recyclers. If there is any legal obligation for disposal, you may check with local authorities to locate approved batteries recyclers in your area. It is recommended not to dispose off batteries along with other waste or municipal solid waste.
- **Metal Components:** At the end-of-life of the product, Metal Components like Aluminum or MS enclosures and copper cables may be retained for some other suitable use or it may be given away as scrap to metal industries.
- **Plastic Components:** At the end-of-life of the product, plastic components must be disposed through plastic recyclers. If there is any legal obligation for disposal, you may check with local authorities to locate approved plastic recyclers in your area.

After end-of-life of the Matrix products, if you are unable to dispose-off the products or unable to locate e-waste recyclers, you may return the products to Matrix Return Material Authorization (RMA) department.

Make sure these are returned with:

- proper documentation and RMA number
- proper packing
- pre-payment of the freight and logistic costs.

Such products will be disposed-off by Matrix.

“SAVE ENVIRONMENT SAVE EARTH”

Open Source Licensing Terms and Conditions



These licensing terms and conditions are applicable only for the SATATYA onboard device client application.

- The firmware of this product also includes some of the Open-Source software released under GNU General Public License (GPL) Version 2. Terms of this license is printed in full below.
- The source of the open source software used in this product will be available, upon written request from:

R&D Team
Matrix ComSec Pvt. Ltd.
394, Makarpura GIDC,
Vadodara - 390 010
Gujarat
India.

Customer shall bear the shipping and handling charges.

GNU GENERAL PUBLIC LICENSE Version 2, June 1991

Copyright (C) 1989, 1991 Free Software Foundation, Inc.,
51 Franklin Street, Fifth Floor, Boston, MA 02110-1301 USA
Everyone is permitted to copy and distribute verbatim copies
of this license document, but changing it is not allowed.

Preamble

The licenses for most software are designed to take away your freedom to share and change it. By contrast, the GNU General Public License is intended to guarantee your freedom to share and change free software--to make sure the software is free for all its users. This General Public License applies to most of the Free Software Foundation's software and to any other program whose authors commit to using it. (Some other Free Software Foundation software is covered by the GNU Lesser General Public License instead.) You can apply it to your programs, too.

When we speak of free software, we are referring to freedom, not price. Our General Public Licenses are designed to make sure that you have the freedom to distribute copies of free software (and charge for this service if you wish), that you receive source code or can get it if you want it, that you can change the software or use pieces of it in new free programs; and that you know you can do these things.

To protect your rights, we need to make restrictions that forbid anyone to deny you these rights or to ask you to surrender the rights. These restrictions translate to certain responsibilities for you if you distribute copies of the software, or if you modify it.

For example, if you distribute copies of such a program, whether gratis or for a fee, you must give the recipients all the rights that you have. You must make sure that they, too, receive or can get the source code. And you must show them these terms so they know their rights.

We protect your rights with two steps: (1) copyright the software, and (2) offer you this license which gives you legal permission to copy, distribute and/or modify the software.

Also, for each author's protection and ours, we want to make certain that everyone understands that there is no warranty for this free software. If the software is modified by someone else and passed on, we want its recipients to know that what they have is not the original, so that any problems introduced by others will not reflect on the original authors' reputations.

Finally, any free program is threatened constantly by software patents. We wish to avoid the danger that redistributors of a free program will individually obtain patent licenses, in effect making the program proprietary. To prevent this, we have made it clear that any patent must be licensed for everyone's free use or not licensed at all.

The precise terms and conditions for copying, distribution and modification follow.

GNU GENERAL PUBLIC LICENSE
TERMS AND CONDITIONS FOR COPYING, DISTRIBUTION AND MODIFICATION

0. This License applies to any program or other work which contains a notice placed by the copyright holder saying it may be distributed under the terms of this General Public License. The "Program", below, refers to any such program or work, and a "work based on the Program" means either the Program or any derivative work under copyright law: that is to say, a work containing the Program or a portion of it, either verbatim or with modifications and/or translated into another language. (Hereinafter, translation is included without limitation in the term "modification".) Each licensee is addressed as "you".

Activities other than copying, distribution and modification are not covered by this License; they are outside its scope. The act of running the Program is not restricted, and the output from the Program is covered only if its contents constitute a work based on the Program (independent of having been made by running the Program). Whether that is true depends on what the Program does.

1. You may copy and distribute verbatim copies of the Program's source code as you receive it, in any medium, provided that you conspicuously and appropriately publish on each copy an appropriate copyright notice and disclaimer of warranty; keep intact all the notices that refer to this License and to the absence of any warranty; and give any other recipients of the Program a copy of this License along with the Program.

You may charge a fee for the physical act of transferring a copy, and you may at your option offer warranty protection in exchange for a fee.

2. You may modify your copy or copies of the Program or any portion of it, thus forming a work based on the Program, and copy and distribute such modifications or work under the terms of Section 1 above, provided that you also meet all of these conditions:

- a) You must cause the modified files to carry prominent notices stating that you changed the files and the date of any change.
- b) You must cause any work that you distribute or publish, that in

whole or in part contains or is derived from the Program or any part thereof, to be licensed as a whole at no charge to all third parties under the terms of this License.

c) If the modified program normally reads commands interactively when run, you must cause it, when started running for such interactive use in the most ordinary way, to print or display an announcement including an appropriate copyright notice and a notice that there is no warranty (or else, saying that you provide a warranty) and that users may redistribute the program under these conditions, and telling the user how to view a copy of this License. (Exception: if the Program itself is interactive but does not normally print such an announcement, your work based on the Program is not required to print an announcement.)

These requirements apply to the modified work as a whole. If identifiable sections of that work are not derived from the Program, and can be reasonably considered independent and separate works in themselves, then this License, and its terms, do not apply to those sections when you distribute them as separate works. But when you distribute the same sections as part of a whole which is a work based on the Program, the distribution of the whole must be on the terms of this License, whose permissions for other licensees extend to the entire whole, and thus to each and every part regardless of who wrote it.

Thus, it is not the intent of this section to claim rights or contest your rights to work written entirely by you; rather, the intent is to exercise the right to control the distribution of derivative or collective works based on the Program.

In addition, mere aggregation of another work not based on the Program with the Program (or with a work based on the Program) on a volume of a storage or distribution medium does not bring the other work under the scope of this License.

3. You may copy and distribute the Program (or a work based on it, under Section 2) in object code or executable form under the terms of Sections 1 and 2 above provided that you also do one of the following:

- a) Accompany it with the complete corresponding machine-readable source code, which must be distributed under the terms of Sections 1 and 2 above on a medium customarily used for software interchange; or,
- b) Accompany it with a written offer, valid for at least three years, to give any third party, for a charge no more than your cost of physically performing source distribution, a complete machine-readable copy of the corresponding source code, to be distributed under the terms of Sections 1 and 2 above on a medium customarily used for software interchange; or,
- c) Accompany it with the information you received as to the offer to distribute corresponding source code. (This alternative is allowed only for noncommercial distribution and only if you received the program in object code or executable form with such an offer, in accord with Subsection b above.)

The source code for a work means the preferred form of the work for making modifications to it. For an executable work, complete source code means all the source code for all modules it contains, plus any associated interface definition files, plus the scripts used to control compilation and installation of the executable. However, as a

special exception, the source code distributed need not include anything that is normally distributed (in either source or binary form) with the major components (compiler, kernel, and so on) of the operating system on which the executable runs, unless that component itself accompanies the executable.

If distribution of executable or object code is made by offering access to copy from a designated place, then offering equivalent access to copy the source code from the same place counts as distribution of the source code, even though third parties are not compelled to copy the source along with the object code.

4. You may not copy, modify, sublicense, or distribute the Program except as expressly provided under this License. Any attempt otherwise to copy, modify, sublicense or distribute the Program is void, and will automatically terminate your rights under this License. However, parties who have received copies, or rights, from you under this License will not have their licenses terminated so long as such parties remain in full compliance.

5. You are not required to accept this License, since you have not signed it. However, nothing else grants you permission to modify or distribute the Program or its derivative works. These actions are prohibited by law if you do not accept this License. Therefore, by modifying or distributing the Program (or any work based on the Program), you indicate your acceptance of this License to do so, and all its terms and conditions for copying, distributing or modifying the Program or works based on it.

6. Each time you redistribute the Program (or any work based on the Program), the recipient automatically receives a license from the original licensor to copy, distribute or modify the Program subject to these terms and conditions. You may not impose any further restrictions on the recipients' exercise of the rights granted herein. You are not responsible for enforcing compliance by third parties to this License.

7. If, as a consequence of a court judgment or allegation of patent infringement or for any other reason (not limited to patent issues), conditions are imposed on you (whether by court order, agreement or otherwise) that contradict the conditions of this License, they do not excuse you from the conditions of this License. If you cannot distribute so as to satisfy simultaneously your obligations under this License and any other pertinent obligations, then as a consequence you may not distribute the Program at all. For example, if a patent license would not permit royalty-free redistribution of the Program by all those who receive copies directly or indirectly through you, then the only way you could satisfy both it and this License would be to refrain entirely from distribution of the Program.

If any portion of this section is held invalid or unenforceable under any particular circumstance, the balance of the section is intended to apply and the section as a whole is intended to apply in other circumstances.

It is not the purpose of this section to induce you to infringe any patents or other property right claims or to contest validity of any such claims; this section has the sole purpose of protecting the integrity of the free software distribution system, which is implemented by public license practices. Many people have made generous contributions to the wide range of software distributed

through that system in reliance on consistent application of that system; it is up to the author/donor to decide if he or she is willing to distribute software through any other system and a licensee cannot impose that choice.

This section is intended to make thoroughly clear what is believed to be a consequence of the rest of this License.

8. If the distribution and/or use of the Program is restricted in certain countries either by patents or by copyrighted interfaces, the original copyright holder who places the Program under this License may add an explicit geographical distribution limitation excluding those countries, so that distribution is permitted only in or among countries not thus excluded. In such case, this License incorporates the limitation as if written in the body of this License.

9. The Free Software Foundation may publish revised and/or new versions of the General Public License from time to time. Such new versions will be similar in spirit to the present version, but may differ in detail to address new problems or concerns.

Each version is given a distinguishing version number. If the Program specifies a version number of this License which applies to it and "any later version", you have the option of following the terms and conditions either of that version or of any later version published by the Free Software Foundation. If the Program does not specify a version number of this License, you may choose any version ever published by the Free Software Foundation.

10. If you wish to incorporate parts of the Program into other free programs whose distribution conditions are different, write to the author to ask for permission. For software which is copyrighted by the Free Software Foundation, write to the Free Software Foundation; we sometimes make exceptions for this. Our decision will be guided by the two goals of preserving the free status of all derivatives of our free software and of promoting the sharing and reuse of software generally.

NO WARRANTY

11. BECAUSE THE PROGRAM IS LICENSED FREE OF CHARGE, THERE IS NO WARRANTY FOR THE PROGRAM, TO THE EXTENT PERMITTED BY APPLICABLE LAW. EXCEPT WHEN OTHERWISE STATED IN WRITING THE COPYRIGHT HOLDERS AND/OR OTHER PARTIES PROVIDE THE PROGRAM "AS IS" WITHOUT WARRANTY OF ANY KIND, EITHER EXPRESSED OR IMPLIED, INCLUDING, BUT NOT LIMITED TO, THE IMPLIED WARRANTIES OF MERCHANTABILITY AND FITNESS FOR A PARTICULAR PURPOSE. THE ENTIRE RISK AS TO THE QUALITY AND PERFORMANCE OF THE PROGRAM IS WITH YOU. SHOULD THE PROGRAM PROVE DEFECTIVE, YOU ASSUME THE COST OF ALL NECESSARY SERVICING, REPAIR OR CORRECTION.

12. IN NO EVENT UNLESS REQUIRED BY APPLICABLE LAW OR AGREED TO IN WRITING WILL ANY COPYRIGHT HOLDER, OR ANY OTHER PARTY WHO MAY MODIFY AND/OR REDISTRIBUTE THE PROGRAM AS PERMITTED ABOVE, BE LIABLE TO YOU FOR DAMAGES, INCLUDING ANY GENERAL, SPECIAL, INCIDENTAL OR CONSEQUENTIAL DAMAGES ARISING OUT OF THE USE OR INABILITY TO USE THE PROGRAM (INCLUDING BUT NOT LIMITED TO LOSS OF DATA OR DATA BEING RENDERED INACCURATE OR LOSSES SUSTAINED BY YOU OR THIRD PARTIES OR A FAILURE OF THE PROGRAM TO OPERATE WITH ANY OTHER PROGRAMS), EVEN IF SUCH HOLDER OR OTHER PARTY HAS BEEN ADVISED OF THE POSSIBILITY OF SUCH DAMAGES.

END OF TERMS AND CONDITIONS

How to Apply These Terms to Your New Programs

If you develop a new program, and you want it to be of the greatest possible use to the public, the best way to achieve this is to make it free software which everyone can redistribute and change under these terms.

To do so, attach the following notices to the program. It is safest to attach them to the start of each source file to most effectively convey the exclusion of warranty; and each file should have at least the "copyright" line and a pointer to where the full notice is found.

```
<one line to give the program's name and a brief idea of what it does.>
Copyright (C) <year> <name of author>
```

```
This program is free software; you can redistribute it and/or modify
it under the terms of the GNU General Public License as published by
the Free Software Foundation; either version 2 of the License, or
(at your option) any later version.
```

```
This program is distributed in the hope that it will be useful,
but WITHOUT ANY WARRANTY; without even the implied warranty of
MERCHANTABILITY or FITNESS FOR A PARTICULAR PURPOSE. See the
GNU General Public License for more details.
```

```
You should have received a copy of the GNU General Public License along
with this program; if not, write to the Free Software Foundation, Inc.,
51 Franklin Street, Fifth Floor, Boston, MA 02110-1301 USA.
```

Also add information on how to contact you by electronic and paper mail.

If the program is interactive, make it output a short notice like this when it starts in an interactive mode:

```
Gnomovision version 69, Copyright (C) year name of author
Gnomovision comes with ABSOLUTELY NO WARRANTY; for details type `show w'.
This is free software, and you are welcome to redistribute it
under certain conditions; type `show c' for details.
```

The hypothetical commands `show w' and `show c' should show the appropriate parts of the General Public License. Of course, the commands you use may be called something other than `show w' and `show c'; they could even be mouse-clicks or menu items--whatever suits your program.

You should also get your employer (if you work as a programmer) or your school, if any, to sign a "copyright disclaimer" for the program, if necessary. Here is a sample; alter the names:

```
Yoyodyne, Inc., hereby disclaims all copyright interest in the program
`Gnomovision' (which makes passes at compilers) written by James Hacker.
```

```
<signature of Ty Coon>, 1 April 1989
Ty Coon, President of Vice
```

This General Public License does not permit incorporating your program into proprietary programs. If your program is a subroutine library, you may consider it more useful to permit linking proprietary applications with the library. If this is what you want to do, use the GNU Lesser General Public License instead of this License.



MATRIX COMSEC

Head Office:

394-GIDC, Makarpura, Vadodara - 390010, India.

Ph:(+91)18002587747

E-mail: Tech.Support@MatrixComSec.com

www.matrixcomsec.com