

# SATATYA PZCR20ML33CWP

System Manual

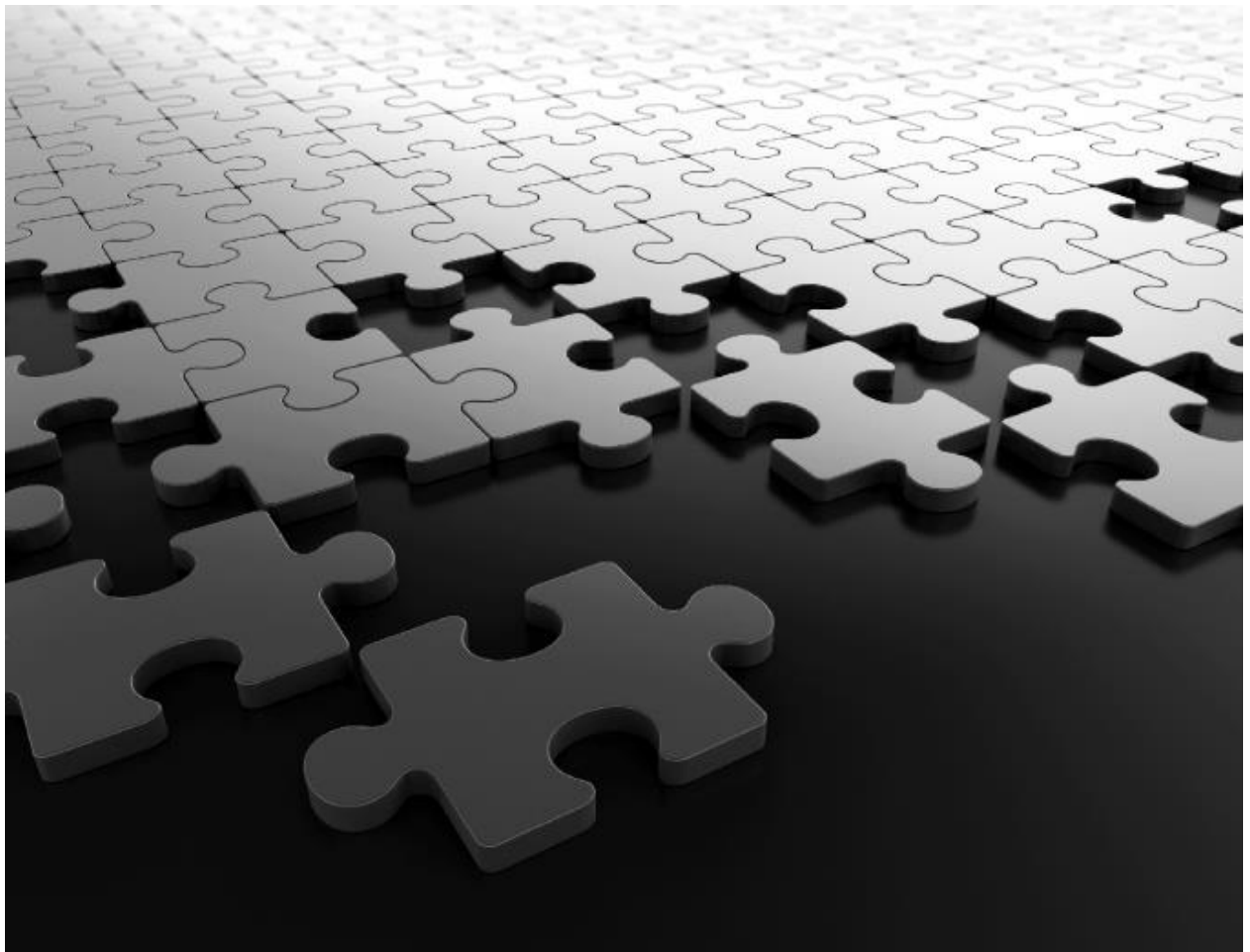

---

# Documentation Disclaimer

Matrix Comsec reserves the right to make changes in the design or components of the product as engineering and manufacturing may warrant. Specifications are subject to change without notice.

This is a general documentation for all variants of the product. The product may not support all the features and facilities described in the documentation.

Information in this documentation may change from time to time. Matrix Comsec reserves the right to revise information in this publication for any reason without prior notice. Matrix Comsec makes no warranties with respect to this documentation and disclaims any implied warranties. While every precaution has been taken in the preparation of this system manual, Matrix Comsec assumes no responsibility for errors or omissions. Neither is any liability assumed for damages resulting from the use of the information contained herein.

Neither Matrix Comsec nor its affiliates shall be liable to the buyer of this product or third parties for damages, losses, costs or expenses incurred by the buyer or third parties as a result of: accident, misuse or abuse of this product or unauthorized modifications, repairs or alterations to this product or failure to strictly comply with Matrix Comsec operating and maintenance instructions.

## Warranty

For product registration and warranty related details visit us at:

<http://www.matrixcomsec.com/product-registration-form.html>

## Copyright

All rights reserved. No part of this system manual may be copied or reproduced in any form or by any means without the prior written consent of Matrix Comsec.

*Release date: March 27, 2023 11:26 AM*

---

# Preface

Thanks for your kind of using our network dome camera products. This IP monitoring product is a dome camera, developed specially for monitoring network videos, which adopt the high-performance, single SOC chip to form a media processor integrating audio and video collection, compression and transmission with standard H.264 and H.265 code algorithms ensuring a clearer and smoother video transmission. The embedded Web Server allows users to conveniently achieve real-time monitoring and remote control of the front-end cameras via IE browser.

---

# Statement

This manual may have inaccuracies, inconsistencies in the operation and function of the product or misprint.

- We will update the information of the manual based on the enhancement and changes of product functions, which will be shown in the latest version of the manual without further notice.
- Due to the constant adoption of new technologies, the parameters of the products are subject to change without further notice.
- This manual provides reference and guidance for customs only, which doesn't guarantee a total consistency with the real subject. Please take the real object as actual application.
- The parts, components and accessories mentioned in the manual don't represent the standard configuration of the equipment. Please refer to the packing list for details.
- All text, forms and figure information in this manual are protected by relevant laws of the country. Please don't take it for personal usage without permission.

## Target Audience

This manual is mainly applicable to the following:

- System Planners
- On-site Technical Support and Maintenance Staff
- Administrators in charge of installation, configuration and maintenance
- Users of the product

---

# Contents

1.	Precautions .....	- 1 -
2.	Product overview.....	- 4 -
	2.1 Main functions and characteristics .....	- 4 -
	2.2 Main application occasions .....	- 6 -
3.	Installation Instructions.....	- 7 -
	3.1 Preparation for Installation .....	- 7 -
	3.2 Installation methods of dome cameras.....	- 8 -
	3.3 Illustrations of dome camera and interface dimensions .....	- 10 -
	3.4 Installation steps(take wall-mounted installation as an example) .....	- 12 -
	3.5 Illustration of external wiring.....	- 13 -
4.	Descriptions of functions.....	- 15 -
	4.1 Basic function description.....	- 15 -
5.	WEB client.....	- 17 -
	5.1 Operating Environment .....	- 17 -
	5.2 Instructions for embedded Web server .....	- 17 -
	5.3 Login Device.....	- 17 -
	5.4 Audios and videos preview.....	- 21 -
	5.5 Playback.....	- 29 -
	5.6 Log.....	- 32 -
	5.7 Configuration .....	- 33 -
	5.8 Audio Video Set.....	- 37 -
	5.9 Dome Set.....	- 53 -
	5.10 Network .....	- 61 -
	5.11 Event Schedule.....	- 72 -
	5.12 Smart surveillance (VCA) .....	- 78 -
	5.13 Storage .....	- 103 -
	5.14 System.....	- 107 -
6.	Simple Troubleshooting .....	- 117 -
7.	After-sales Services .....	- 119 -
8.	Appendix I Lightning Protection and Surge Protection .....	- 120 -

---



# 1. Precautions

The purpose of this Manual is to ensure that users can operate the products properly, thus avoiding danger or property damage. Please read this Manual carefully and keep it properly for future reference before using the products.

As shown below, the precautionary measures are divided into two parts: “Warning” and “Note”:

**Warning: ignoring the warning may result in death or severe injury.**

**Attention: ignoring the precautions may result in injury or property damage.**

	
Warning Alert users to prevent the potential danger of death or serious injury	Note Alert users to prevent the potential danger of injury or property damage



## **Warning:**

1. Input voltage should meet both the SELV (Safety Extra Low Voltage)
2. Contact the distributor for abnormal operation. Do not disassemble or modify the devices in any way.
3. Moisture must be avoided for indoor devices in case of fire and electric shock.
4. Install the equipment on the ceiling to ensure that it can withstand at least 4 times the weight of the equipment.
5. Do not look directly at the concentrated laser beam.
6. The camera should be installed by professional personnel in the way complying with local laws and regulations.
7. The easy-to-use power failure protection device should be installed in building installation wiring.
8. Don't disassemble internal parts of the camera privately. No internal part

---

can be privately repaired by the user. Repair work can only be performed by maintenance staff authorized by our company and we will not be responsible for any problem caused by unauthorized modification or maintenance of the product.



**Note:**

1. Please check whether the power supply is correct before the camera starts functioning.
2. Please do not drop the product on the ground or do not strongly knock it.
3. Please don't directly touch the glass and spherical outer cover in front of the lens. To clean it, you may wipe the surface with microfiber cleaning cloth, such as glasses cloth. Don't wipe it too hard or wipe with water.
4. Don't focus at strong light (such as light, sunlight, laser, etc.); otherwise, over-bright or light pulling phenomenon (not the fault of the camera) may occur and the service life of the image sensor may also be shortened.
5. Avoid putting it at places that are damp, dusty, extremely hot, extremely cold or with strong electromagnetic radiation.
6. It is strongly recommended to transport the camera with the original package.
7. Long-term high-speed cruising of the camera may lead to ring sliding and aging of the synchronous belt, thus affecting the machine's service life.
8. The bending radius of optical fiber cable should not be less than 20mm.
9. The working bid documents of the laser is -10°C~ +40°C. Beyond this range, the laser will shut down automatically.
10. For details about functions of the camera, please refer to the Help file at the right upper corner of the IE browser.
11. The analog video port is for rapid debugging and is not the formal video output port.
12. The running speed of the dome camera will be adjusted automatically based on the external environment and slightly decrease in the ultra-low

---

temperature (-under 20°C).

13. Please use the product under the requirement of working environment.

<b>Parameters</b>	<b>Dome camera</b>
Ambient temperature	-40°C~+70°C
Ambient humidity	<95% (no condensation)
Atmospheric pressure	86~106KPa
Power supply	AC 24V/3.0A

**Attention:** make sure that the outdoor installation of the dome camera meets the waterproof requirements

14. Illustration of dome camera installation environment

To get rid of the vapor in dome camera cover affecting the video effect and the life of electrical parts, please assemble the ball cover under the condition of ventilated and dry environment, and ensure that the screws of the dome camera are tightened.



---

## 2. Product overview

This is a high-definition network high-speed dome camera, which are embedded digital monitoring product integrating traditional analog camera and network video server. They adopt embedded Linux operation system and advanced hardware platform, with high dispatching efficiency, code solidified in Flash, small volume, Low power consumption, high stability and reliability.

This dome camera adopts the integrated design, synchronous belt drive and precision stepping motor, which can run accurately and stably; different installation methods meet the needs of different occasions; with weather-wise outdoor design, double-layer shell structure, built-in fan and intelligent start; various monitoring methods, such as scanning, cruising, pattern path, etc., are flexible to be selected; integrated preset function ensures more powerful performance.

**Special attention:** the product function description and support functions in this manual are based on the full-function dome camera.

### 2.1 Main functions and characteristics

#### 2.1.1 Basic functions

- Heartbeat function: through the heartbeat mechanism, the management host can get the real-time operation status of the front-end network dome camera;
- PTZ control function: the RS485 interface (full-function dome camera) can support PTZ control and multiple decoder protocols and dome camera protocols;
- Alarming function: alarm input, alarm output, mobile detection alarm, video

- 
- loss / blocking alarm, email alarm, alarm link output;
- Voice intercom: two-way voice intercom, one-way voice acquisition / broadcast;
  - User management: multi user limits management modes. Senior administrator can create 4 sub-levels of users with different level of user's rights for high system security;
  - The embedded Web Server allows IE browser;
  - Provide open SDK development package;
  - Compression processing capacity;
  - Support 25 frames per second (PAL system) / 30 frames per second (NTSC system)
  - Support H.265 coding (full-function starlight dome camera), support changing not only code rate but also frame rate. When setting the video Fig. quality, it can also limit the video Fig. compression code stream;
  - Support 2MP; Maximum Resolution - 1920x1080
    - Main Stream - PAL: 50fps (1920x1080, 1280x720, 704x576, 640x480); NTSC: 60fps (1920x1080, 1280x720, 704x480, 640x480)
    - Sub Stream - PAL: 25fps (704x576, 704x288, 640x360, 352x288); NTSC:30fps (704x480, 704x240, 640x360, 352x240)
    - Third Stream - PAL 25fps (1920x1080, 704x576, 704x288, 352x288); NTSC: 30fps (1920x1080, 704x480, 70x240, 352x240)
  - Excellent intelligent analysis and tracking function (full function dome camera).

### **2.1.2 Remote access and transmission functions**

- A 10m / 100M adaptive Ethernet port is provided as standard;
- Supports TCP / IP, ICMP, FTP, HTTP, DHCP, DNS, RTSP, PPPOE, NTP, UPnP, SMTP, IGMP, QoS, IPv4, IPv6, Multicast, RTMP;
- Support ONVIF protocol, P2P, GBT28181, GAT1400
- Parameters, real-time video browsing, and viewing webcam status can be

---

set through the application or IE browser. Alarm link can be achieved through network;

- Remote management and maintenance can be achieved through remote network maintenance / upgrading.

## **2.2 Main application occasions**

It is applicable to all kinds of occasions requiring remote network monitoring, such as:

- ATM, vault, teller and other monitoring occasions;
- Factory, workshop, warehouse and other monitoring occasions;
- Urban street monitoring, road condition information collection and other occasions;
- Child-care centers, kindergartens, schools and families where need monitoring;
- Smart building, smart community and other management systems;
- Airport, railway station, bus station and other occasions with frequent crowd gathering and distribution;
- Oil field and coal mine remote operation occasions;

---

## 3. Installation Instructions

### 3.1 Preparation for Installation

#### (1) Basic requirements

Ensure that all electrical work must be conducted in accordance with the latest electrical regulations, fire regulations and related regulations; check whether the packaging is damaged, equipment and accessories are complete, and determine whether the application places and installation methods of PTZ product meet the requirements; please contact the dealer if necessary, please use the product according to the requirements of the working environment.

#### (2) Common installation tools

Prepare the tools actually required according to the actual situations

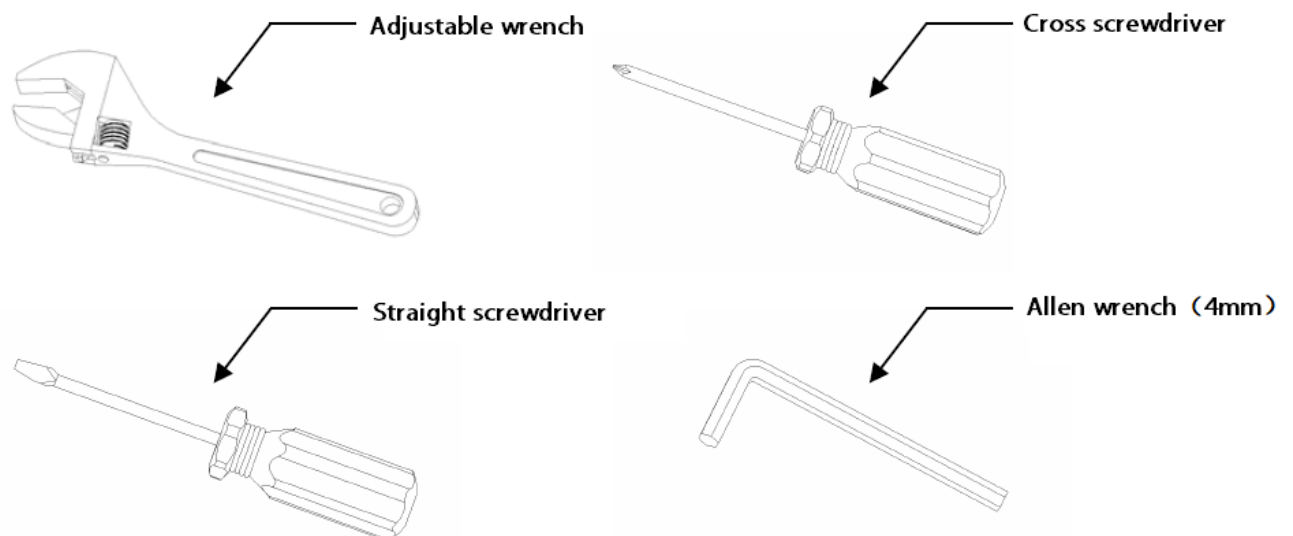

Fig.3.1 Common installation tools

#### (3) Check the strength of the construction of installation space and installation site

Confirm that there is enough space at the installation site to accommodate the product and its mounting structural part. Confirm that the carrying capacity of the ceiling, wall and bracket on which the PTZ is installed must be able to support the total weight of PTZ and its mounting structural part, with a 4 times

---

of safety factor.

Please keep all packaging materials of network camera

After unpacking the network camera, please keep the original packaging materials of network camera properly, and pack the network camera product properly using the packaging materials of network camera and return it to the supplier for handling in case of any problem.

**Note:** Non-original packaging materials may cause accidental damage during transportation.

### 3.2 Installation methods of dome cameras

This series of dome cameras support the following 4 methods of installation

1:Fig.of wall-mounted installation and dimensions

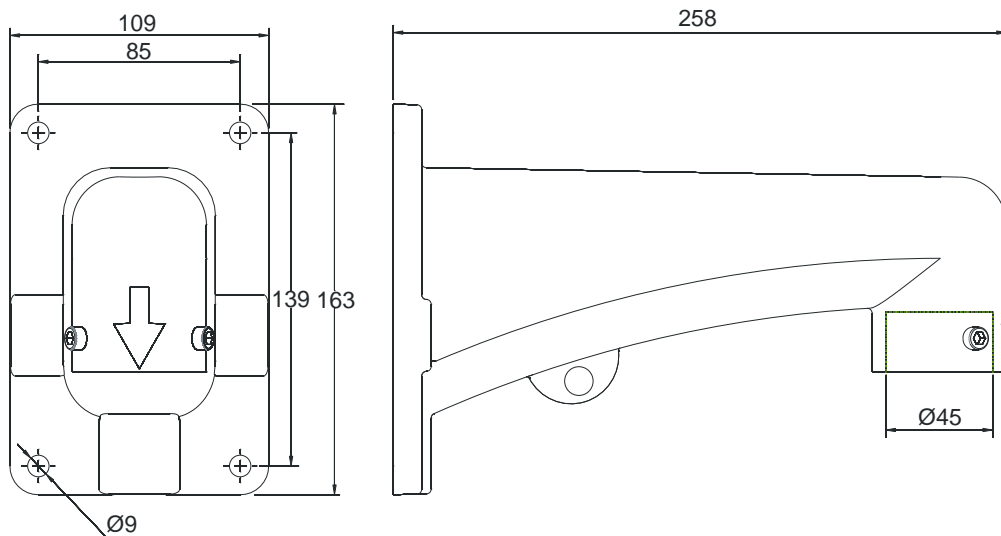

Fig.3.2.1 picture of dimensions of wall-mounted installation arm

2: Picture of ceiling-like installation and dimensions

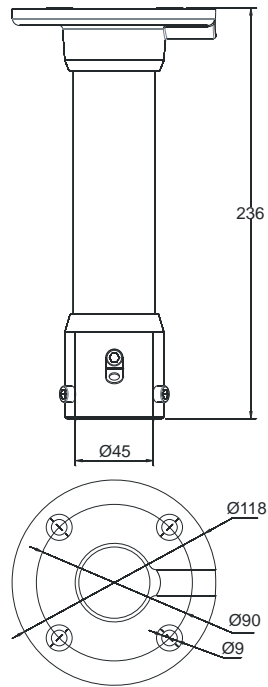

Fig.3.2.2 Picture of dimensions of ceiling installation arm

3: Picture of exterior wall angle installation and dimensions

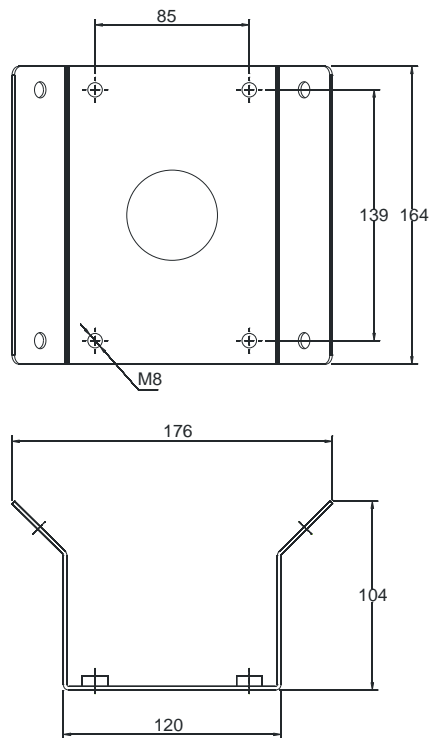

Fig.3.2.3 Picture of dimensions of external wall angle installation arm

---

#### 4: Picture of column-like installation and dimensions

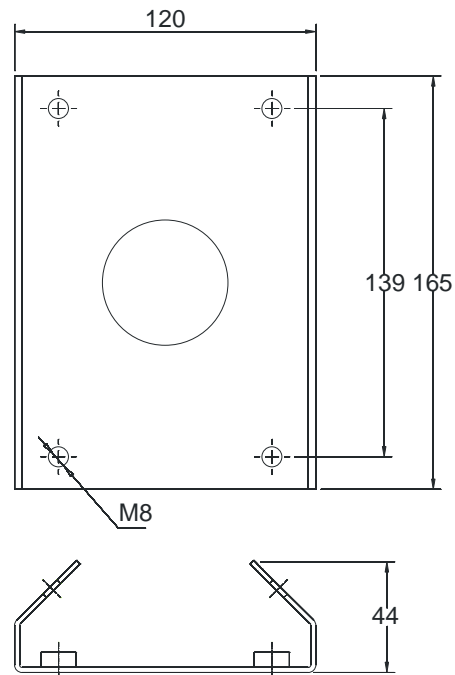

Fig.3.2.4 Picture of dimensions of column-like installation arm

### 3.3 Illustrations of dome camera and interface dimensions

This series of dome cameras adopt the split design with the joints of each part are mainly round. In order to facilitate the installation, the dimensions and specifications of this product have been listed, as shown in the figure below.

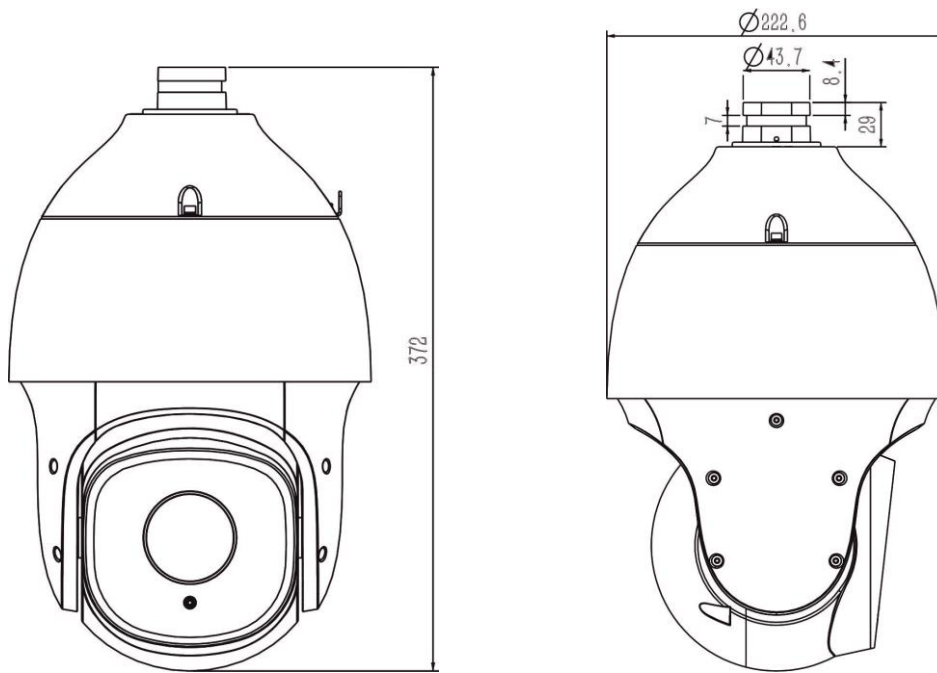

Fig.3.3.3 V3 HD infrared network high speed dome camera dimensions specification

Users can choose the bracket sold by our company, or customized bracket to install this product. The product interface dimensions are shown as follows:

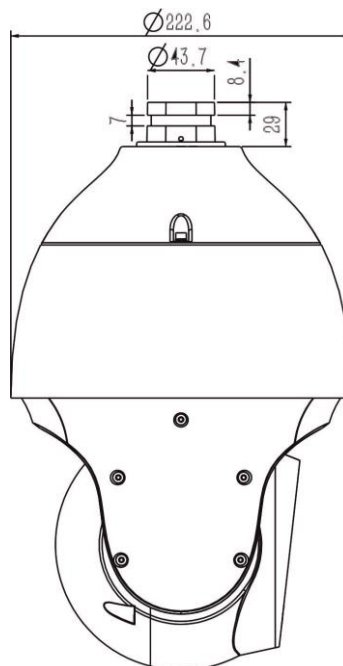

Fig.3.3.4 Picture of dome camera and interface dimensions



---

### 3.4 Installation steps(take wall-mounted installation as an example)

- 1、 Drill holes according to the dimensions of the bracket positioning holes.

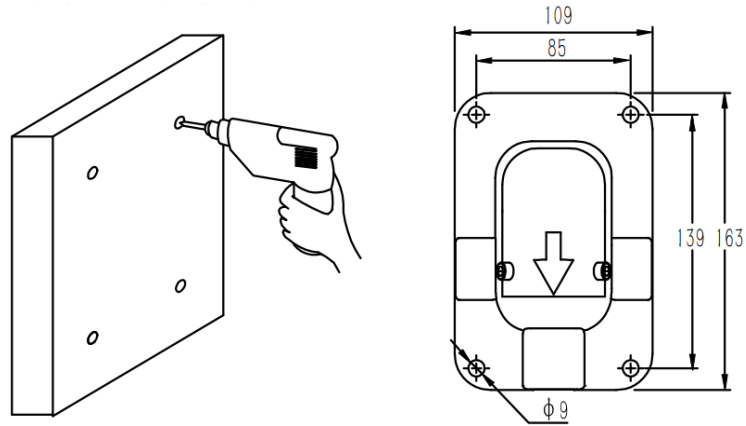

- 2、 Hook up the body of dome camera, tighten the bracket screw, fix the dome camera and bracket and lock the spring buckle.

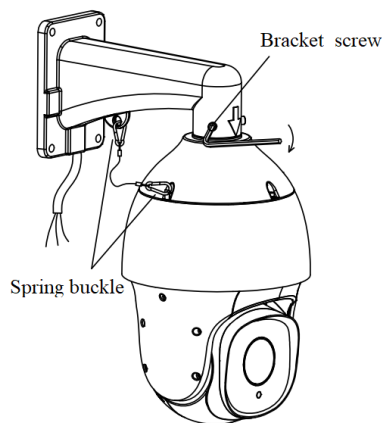

- 3、 Fasten the support arm with the expansion screw to ensure it is stable and tight to finish the installation.

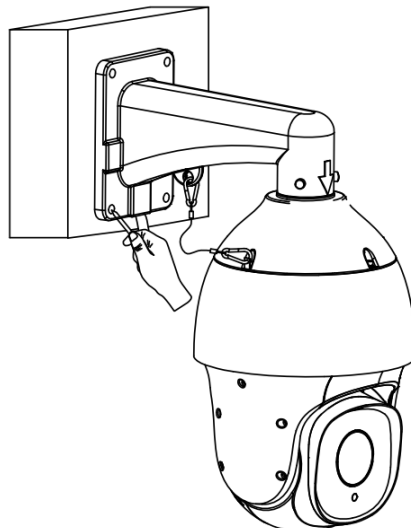

**Note:**

1. The installation surface of the wall-mounted installation bracket must have the capacity to bear enough weight.
2. The outdoor installation shall be completely sealed and moisture-proof; the outgoing cable shall be laid close to the lower edge of the wall mounted installation bracket to avoid rain entering the interior of the dome camera along the cable.

### 3.5 Illustration of external wiring

The dome camera adopts 800mm lead wire to lead out all interfaces from the inside of itself, including power wire, control wire (network wire), audio input wire, audio output wire, analog video wire, alarm input wire, alarm output wire and 485 communication wire. The connecting terminal and its color definition are shown in the figure below.

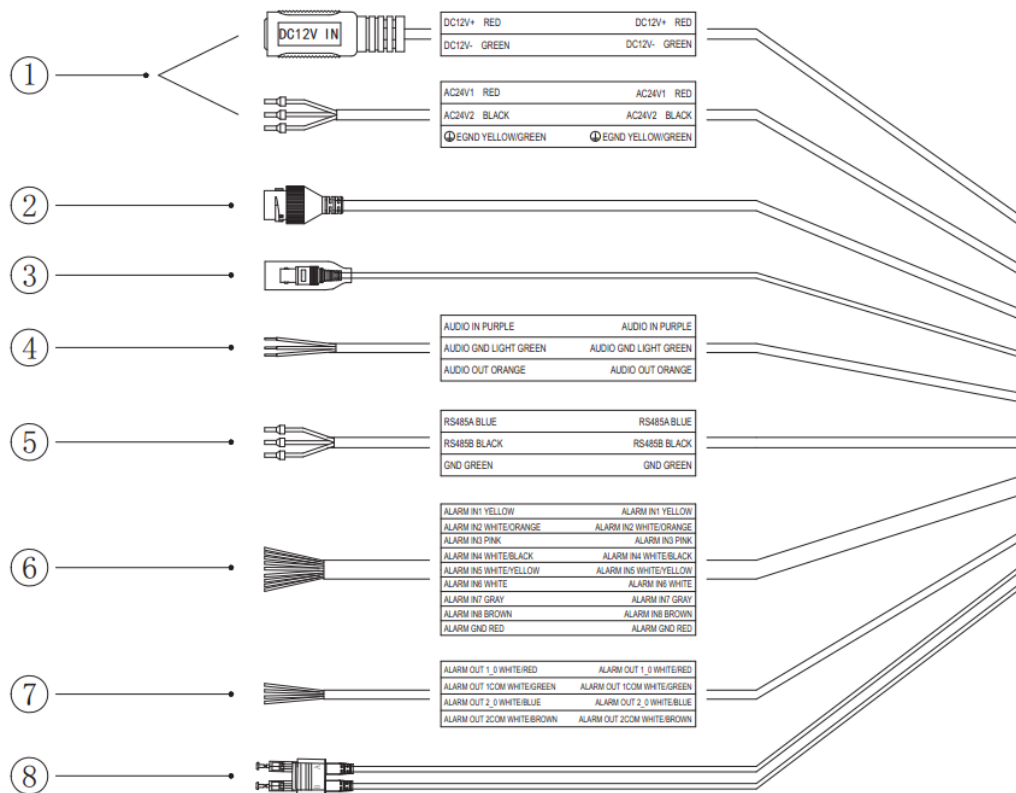

Fig.3.5 Lead wire of dome camera

No.	Port	Description
①	Power Port	Connect AC24V. Lighting protection ground wire: connect to the ground to avoid the damage of the equipment by lighting strike.
②	Network Port	Cable socket connects to the computer host or other network equipment.
		When connecting the network cable, it is recommended that the network cable should not be more than 100m long.
		POE power supply is supported by some models.
③	Analog video	Connect to the analog video monitor.
④	Audio port	Audio inlet connection microphone or other audio sources; audio outlet connection speaker.
⑤	RS485	The camera may be controlled by 485 port on the keyboard or other devices.
⑥	Alarm input	Connect the sensor for switch signal.
⑦	Alarm output	Connection alarm, output switch signal.
⑧	Optical fiber port	Only available for some models.

---

## 4. Descriptions of functions

### 4.1 Basic function description

This section describes the main functions the dome camera and the general principles of implementation, no specific operation methods involved. The specific operation method of different system platforms varies. Generally, the operation manual of the system manufacturer shall prevail. In some cases, there will be some special requirements and operation methods. Please contact the dealer for necessary information.

- Automatic matching technology of PTZ / rotation rate
- The dome camera can automatically adjust the horizontal and vertical rotation rate of the PTZ according to the multiple of variation, which makes the manual operation easier.
- Set up and call preset position
- The preset function is that the dome camera can store the horizontal angle, tilt angle, camera lens focal length and other position parameters of the PTZ in the current state into the memory. These parameters can be called quickly when necessary and the PTZ and camera can be adjusted to this position. The operator can easily and quickly set or call the preset position by controlling the keyboard or equipment.
- Automatically scanning
- The operator can set the left boundary position and right boundary position in advance by controlling the keyboard or equipment conveniently and quickly to achieve the automatic reciprocating scanning of the camera between the left and right boundary at the set speed level. This dome camera can set 8 scanning paths.
- Automatically cruising
- The dome camera can program some preset positions into the

---

automatically scrusing queue in required order through pre-programming. The operator can easily and quickly control the keyboard or equipment to allow the dome camera automatically scan in the specified time interval according to the preset position sequence. Each cruise track can store 32 preset positons.

- Pattern path (pattern scanning)
- The dome camera can record the running track for 180 seconds continuously. After the pattern path function is started, the dome camera can scan and monitor as the recorded running track automatically.
- Watch position function
- The dome camera can be set to automatically perform the set standby action after reaching the standby time: preset position, cruising, scanning, pattern path. The standby time can be set.
- Self recovery function after power off
- The running state of the dome camera can be restored after the power is cut off and recovered to prevent the trouble of re-operating the dome camera caused by the unexpected power off effectively.

---

## 5. WEB client

### 5.1 Operating Environment

It is recommended to run under the operating system environment of Win7 and later. In order to better operate and use the system, and fully reflect the performance and effects, please ensure that the following items are set or installed correctly after the system is successfully installed:

- The display resolution is set to 1920 × 1080 or higher, and the color is set to enhanced color (32-bit), please refer to Windows help document or online help for how to set the resolution and color of monitor.
- Make sure that the font required for this system-Song font is installed in the Windows operating system. If the interface of this system is displayed abnormally, the fonts required by this system may not be installed, or the required fonts have been damaged, and fonts need to be reinstalled.

### 5.2 Instructions for embedded Web server

You need to download controls before using this series of network video products for the first time.

**Note:** Use the IE browser of Windows operating system, to ensure that the version is 8.0 or later. Except for Firefox and Google browsers, please do not use other third-party browsers and any IE browser shell programs such as Maxthon, Window of the World. We do not guarantee that you can log in normally with such software.

### 5.3 Login Device

The default IP address of the device is: **192.168.1.2**. Please set the IP address of the computer and the IP address of the device in the same network

segment: for example, set the IP address of the computer to 192.168.1.3 to access the device through IE browser. Open the IE browser, enter the IP address of the network video device in the address bar, and click "go" to log in to the device. If it is the first time to use, the following interface will appear.

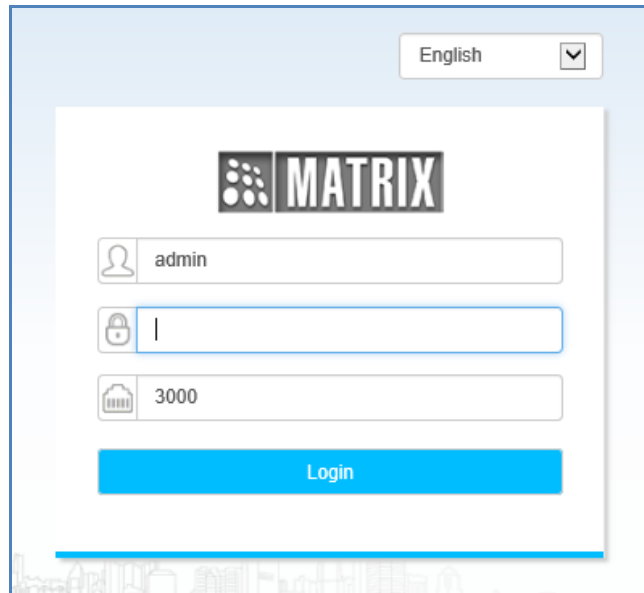

Enter the **User Name as admin(default)** and **Password as admin(default)**.  
Click Login.

### 5.3.1 Equipment activation

The following screen appears if you are logging in for the first time.

User Name: Admin

Old Password: [ ]

Password: [ ]

Password Strength: Poor | Mid | Strong

Please generate 6-15 digits password with two or more combinations of numbers, lowercase, capital letter and special character.

Password Confirm: [ ]

Authority: Admin

Email: [ ]

Optional (For Password Reset)

Save Back

Fig.5.3.1.1 Equipment activation interface

---

Set the login password in the activating device window and click Save to enter the IE login interface.

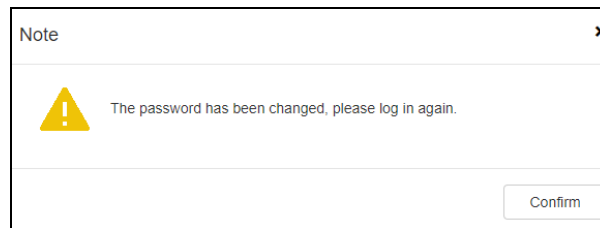

Fig.5.3.1.2 Prompt box for activating device

Click [Confirm].

### 5.3.2 IE login interface



Fig.5.3.2.1 IE login interface

Enter the correct User Name and the new Password you set in the login window. The password is the one set at the time of activation. Click **Login**.

If the equipment port number is modified, you need to enter the correct port number, and the default port number is 3000.

The video preview serial interface will prompt the link to download the video plug-in as Fig.5.3.2.2. Click the link to download and install the plug-in. The IE interface needs to be closed during installation.



Please click to download the plugin. If installed already, please just press F5 to refresh it (no need install again). Please close the browser during installing.

Fig.5.3.2.2 Download the video plug-in

After the video plug-in is installed successfully, enter the device IP again and log in the correct account password to enter the preview interface.

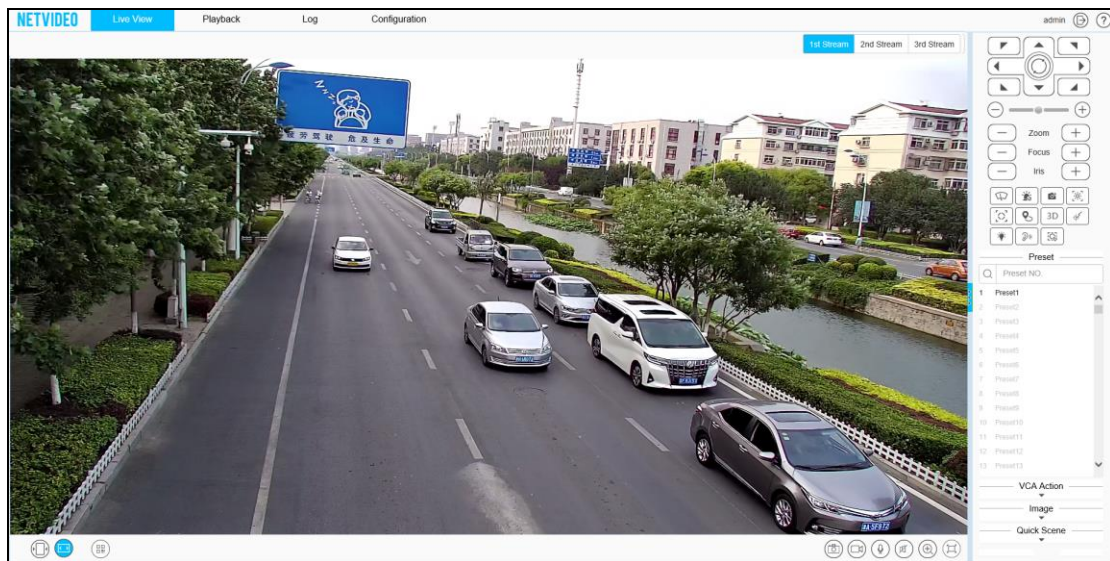

Fig.5.3.2.3 preview interface of video

After you log in to the system, the prompt box of "change password" will appear in the lower right corner of the desktop. Please click the text in the box, link to the user management interface, select the user, and click "edit", as shown in the figure below.

Note: In order to ensure the security of your information, please be sure to change the initial password!

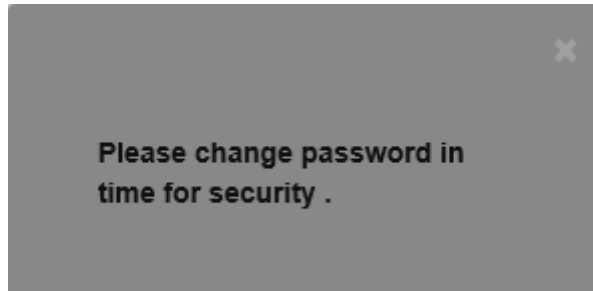

Fig. 5.3.2.4 Change password prompt box)

Fig. 5.3.2.5 Change the password









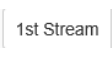

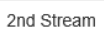
## 5.4 Audios and videos preview

After successful login, the system will display the [Live View] interface by default. In other interfaces, users can return to the video preview interface by clicking the [Live View] button at the top of the interface.

This interface mainly controls the front-end equipment, such as the pan tilt, lens and so on.

### 5.4.1 Button of video preview interface



Icon	Description
	<p>Click <b>1st Stream</b>; the video window will display the primary code stream, and the primary code stream will be displayed by default.</p>

	<p>Click <b>2nd Stream</b>; the video window will display secondary code stream after selection.</p>
	<p>Click <b>3rd Stream</b>; the video window will display third code stream after selection.</p>
	<p>Click <b>Fixed Ratio</b>; the video will be displayed at a fixed scale.</p>
	<p>Click <b>Fit Window</b>; the video will automatically adapt to the computer resolution display.</p>
	<p>Click <b>QR Code</b>. The QR code pop up appears. Users can scan the QR code according to the type of mobile phone and download the mobile client. A third QR code will appear after the equipment is connected to the public network, and you can add the equipment by scanning on the mobile client.</p>
	<p>Click <b>Snapshot</b>. Local manual snapshot will be enabled and it will save the preview picture locally, the storage path of the snapshot file can be modified by itself, the modification page: configuration system settings local settings preview snapshot save path.</p>
	<p>Click <b>Record</b>. Local manual recording will be enabled and it will start local recording, the storage path of recording file can be modified by itself, modification page: configuration - system settings - local settings - saving path of recording file.</p>
	<p>Click <b>Talkback</b>. This is the Voice intercom switch; it can transmit local audio to the front-end equipment through the network for output.</p>
	<p>Click <b>Sound</b>. This is the Audio preview volume adjustment button; the local output volume can be adjusted by adjusting the slider position.</p>
	<p>Click <b>Digital Zoom</b>. Click the left mouse button and select the area to be enlarged, and then you can zoom in and view the area. Click the icon again to Zoom out.</p>

	<p>Click <b>Full Screen</b>. Full screen preview video will appear. Double click left mouse button or press the [Esc] key of keyboard to exit full screen preview video status</p>
---	--

### Caution





- All icons are valid when pressed.
- When there is no video in the interface, the audio preview is invalid.
- Talk can only be conducted with one user at the same time, and it is recommended to turn off the intercom in time after completing the talk, so that others can use it.



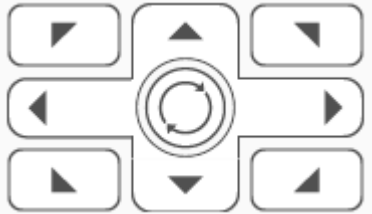

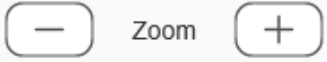
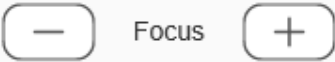
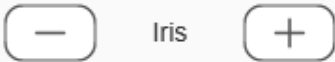
- Click the right arrow  or left arrow  on the right side of the video window to show / hide the control interface.
- This camera supports [Target information] to display the target and information identified by the intelligent algorithm. You can click Target information tab on the right to switch the interface.
- Double click the left mouse button in the preview window to display the full screen. The dome camera can be controlled by keyboard: W“↑”, S“↓”, A“←”, D“→”, I “zoom in”, K “zoom out”, J “focus near”, L “focus far”.

### 5.4.2 PTZ control

The functions supported are as follows:

Icon	Description
	<p>8 direction keys, press the corresponding direction key to control the pan tilt to rotate in the corresponding direction; the center button is the scan shortcut key, press center button can invoke scan 1.</p>

	<p>The slider can adjust the rotation speed of the device. The closer the "-" end is, the slower the speed is, and the closer the "+" end is, the faster the speed is.</p>
	<p>Zoom control button, press "-" control device to perform zoom operation, the field angle becomes larger and the scenery becomes smaller; press "+" control device to perform zoom operation, the field angle becomes smaller and the scenery becomes larger. (this button can also control the electric lens for zooming)</p>
	<p>Focus control button, press "-" control device to perform focusing near operation, the near scene is clear and far away fuzzy; press "+" control device to perform focusing far operation, the far scene is clear and near fuzzy. (this button can also control the electric lens to focus)</p>
	<p>Iris control button, press "-" control device to perform aperture reduction operation, and press "+" control device to perform iris increase operation. (supported by some models)</p>
	<p>Alarm removal button. Alarm can be removed after pressing the button. (Supported by some models)</p>
	<p>Snap button: press the button to turn on the front end interception function.</p>
	<p>Area exposure button: when there's a large light difference of the monitoring scene, the area to be</p>

	<p>adjusted can be selected through the area exposure function to make moderate light of the key monitoring area.</p>
	<p>Area focus button: when there's a deep and large scale scene area of the monitoring scene, you can select the part of the scene that needs to be focused clearly through the area focus function.</p>
	<p>Click the one-key watch button to automatically set the current scene to the watch preset (default preset 1), and turn on the watch function at the same time. If you want to stop the one-key watch function, please cancel the standby action in the dome camera setting-basic setting.</p>
	<p>3D positioning button, click the mouse to control, adjust the scene to be monitored to the video center. Specific operation as follows:</p> <ol style="list-style-type: none"> <li>1、 Click the left key on the required monitoring point in the monitoring video screen, and move the corresponding point to the video center;</li> <li>2、 Press and hold the left key to the bottom right to pull down a rectangular area, then the center of the corresponding delimited area will be moved to the center of the video and zoomed in;</li> <li>3、 Press and hold the left key to the top left to pull out a rectangular area, then move the center of the corresponding delimited area to the center of the video and zoom out.</li> </ol>
	<p>Manual tracking button, click once enabling, and then click the target manually to track the target.</p>

---

### 5.4.3 Preset

Click the ▼ icon to display preset function setting interface.

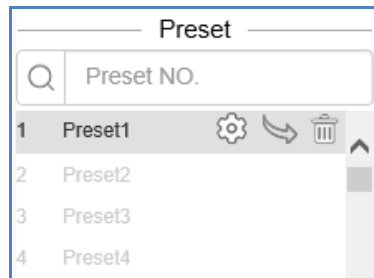

Fig. 5.4.3.1 Preset interface

- The function of the presetting bit is that the camera can store the location parameters of the PTZ under the current status such as the level angle, angle of inclination and the lens focal length of the camera into the storage and the PTZ as well as the camera can be adjusted to this position through calling the these parameters if necessary.
- After logging in the preset position number, you can select the operation of preset position, including set-up, call and delete.
- Preset number can be fill in the blank and use the '🔍' button to find the target preset number to config ('⚙️') or call ('↶'). Call functions are only available for existed presets.

### 5.4.4 VCA Action

Click the ▼ icon to display the operation interface of the intelligent action. The interface includes Auto cruise, Auto scan, Mode and Intelligent Scene.

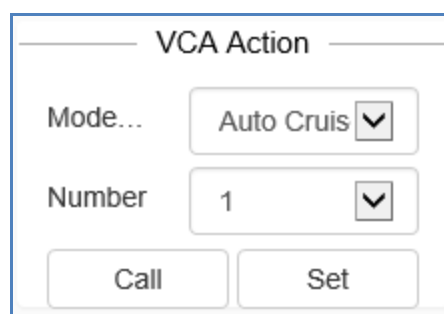

Fig.5.4.4.1 VCA Action

- [Auto cruise]: Arrange some preset into the automatic cruise queue as per the requirements. Calling of this cruise can ensure the automatic cycle call of the equipment as per the set preset order as well as the stipulated interval. Each cruise trajectory can store 32 preset points.
- [Auto scan]: Ensure that through set the left and right limit well in advance, the camera can scan back and forth levelly and automatically with the set speed between the left and right limit.
- [Mode]: It can record the operations like Left/Right/Zoom, and when you call mode it will repeat the operation
- [Intelligent scene]: Through selecting the scene set in advance, the scene change can be realized and the function of intelligent analysis can be started quickly. If the user has set up an intelligent analysis cruise, then the cruise mode is enable after 10 minutes.

### 5.4.5 Image

Click the ▼ icon to display the parameters to adjustment the interface, the interface can be adjusted by the following.

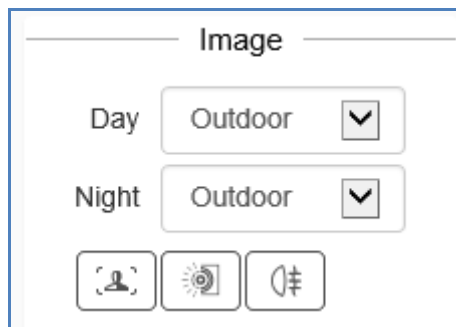





Fig.5.4.5.1 Image setting interface

Icon	Description
Day <input type="text" value="Outdoor"/> ▼	HD effect adjustment, adjust the daytime image effect. The effect is divided into:



Night <input type="text" value="Outdoor"/> <input type="button" value="v"/>	HD effect adjustment, adjust night image effect. The effect is divided into: Outdoor, Indoor, WDR, Motion, Bright, Colorful, customized .etc.
	Button for WDR function. Click the button to turn on WDR function.(Some models support this function).
	Button for HLC function. Click the button to turn on HLC.(Some models support this function).
	Defog function button. Click the button to turn on the defog function.(Some models support this function).

### 5.4.6 Quick Scene

Click the  button to display Scene application template interface. You can modify the parameter as follows:

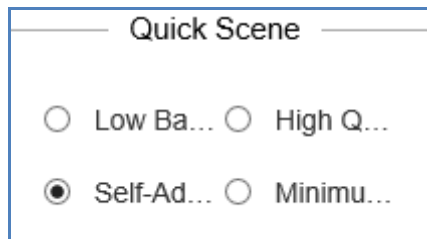

Fig.5.4.6.1 Quick Scene

Icon	Description
<input type="radio"/> Low Ba... <input checked="" type="radio"/> High Q...	According to the specific situation of network environment, choose the appropriate preview mode from [Low Bandwidth] and [High Quality].
<input checked="" type="radio"/> Self-Ad... <input type="radio"/> Minimu...	According to the network environment of equipment transmission, two transmission modes can be selected, i.e., [adaptive] and [shortest delay]. In the case of limited network bandwidth, it is suggested to choose adaptive mode to ensure smooth image; in the application environment with high video quality requirements, it is suggested to choose the shortest delay transmission mode.

## 5.5 Playback

Click [Playback] to enter the [Playback] interface.

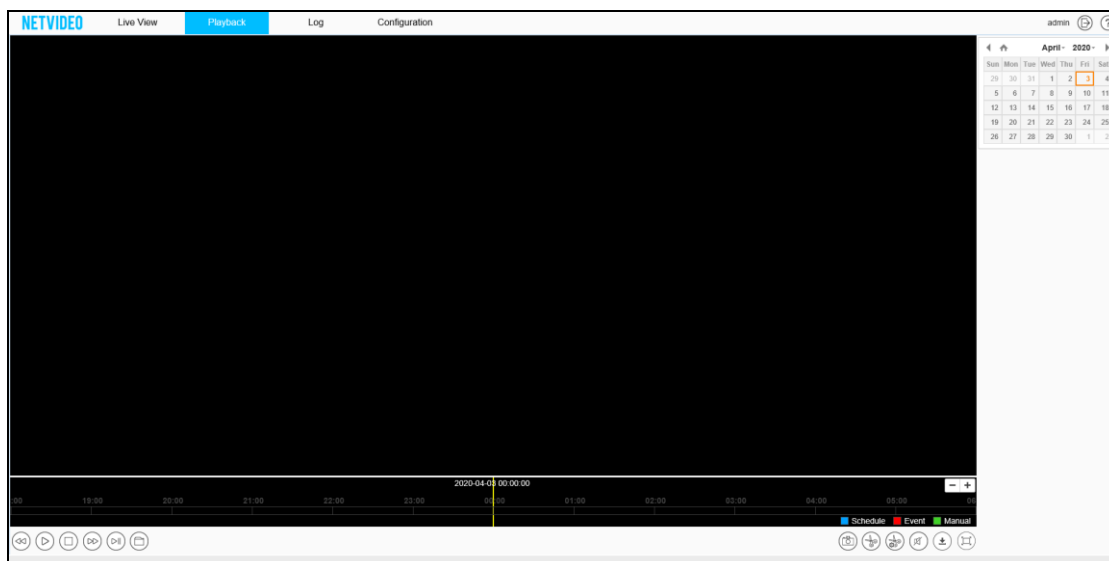











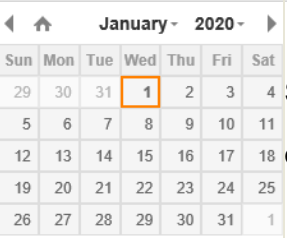

Fig.5.5 playback

### 5.5.1 Refer to the front-end video file

In the playback interface, the user can view the video files of the specified date, and can also snapshot and clip the video. See the following table for basic operation:







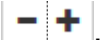

Icon	Description
	Slow forward button. The speed is 1/2 X, 1/4 X, 1/6 X and 1/8 X.
	Play / pause button. Click to start/stop playing video file. Double speed playback will be canceled if necessary.
	“Stop Playing” button. You can stop playing the current file by clicking it.
	Fast forward button. The speed is 2 X, 4 X, 6 X and 8 X.
	Stepping button can playback the video in a single frame.

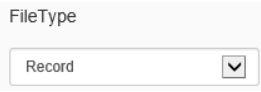
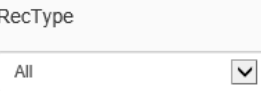
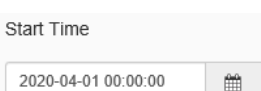
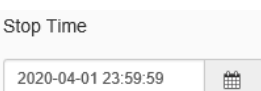
	Browse button, select the video file to play.
	Playback snapshot button, saved by default in C:\Users\john\NetVideoBrowser\CapturePics\.
	Playback clip button: Click to start the clip, and click again to finish the clip. The default saving location is C: \ users \ XYZ \ snapshotpictures \.
	Clip Management: you can view the type of video clip, video clip progress, current status and other information.
	Volume adjustment button, the local output volume can be adjusted by adjusting the slider position.
	Download Management: query or download videos and pictures.
	Full screen play button: in full screen mode, double-click the mouse again at any position to exit from full screen mode.
	Select a date in the calendar, double-click the date, and find the qualified file according to the query criteria.

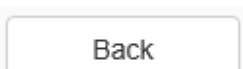
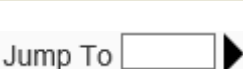
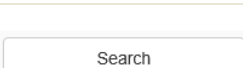
In the time axis mode, users can drag on the time axis to select and view the video files of the corresponding time. After selecting the time point, click the

play button  to play. The time axis can be narrowed or enlarged by click .

In file mode, users can operate according to file type, video recording type, and whether to query remotely. The specific functions of buttons in file mode are as follows:

Icon	Description
	Set the type of file to be queried, such as [Record], [Picture], etc.
	Select the type of video file to be queried. (Supported by some models)
	Select the start time of the video query
	Select the end of the recording query
	Start downloading selected video files
	Stop the selected video file being downloaded.
	Return to the playback interface.
	Jump to the specified page.
	Query: Click to query the corresponding video information.
	Jump to the first page of query results.
	Go to the previous page of the current page.
	Go to the next page of the current page.
	Jump to the last page of query results.
	Lock: the file can be locked and unlocked. When the disk is full and files need to be deleted, the locked files will not be deleted.

## 5.6 Log

Click [Log] to enter the [Log] interface.

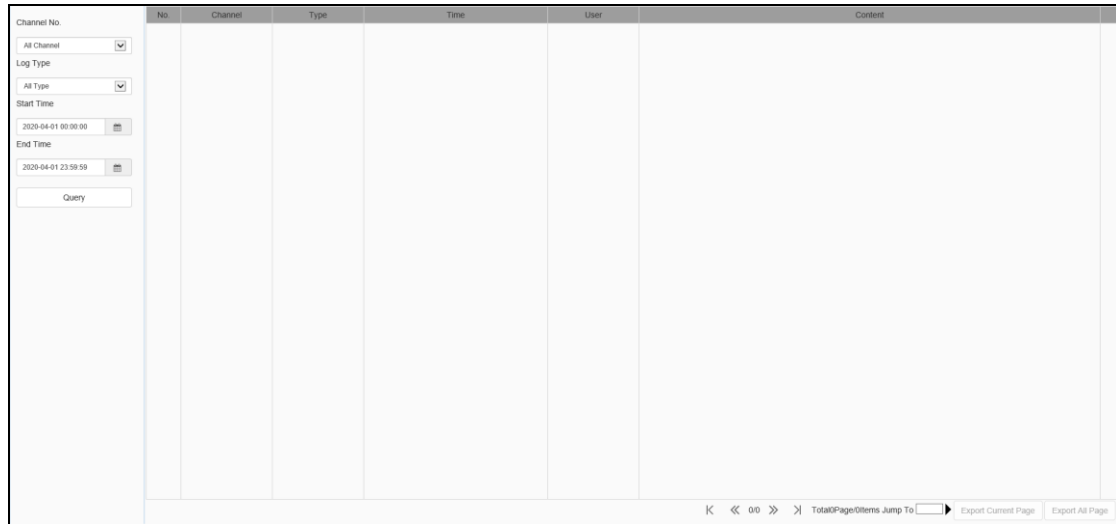

Fig.5.6 Log Interface

- Log interface operation instructions
- Select the channel number to query from the [Channel No.] drop-down list.
- Select the type of log you want to query from the [Log Type] drop-down list.
- Select the start date in the [Start Time] drop-down list, and enter the time in the edit box at the back.
- Select the end date in the [End Time] drop-down list, and enter the time in the edit box next to it.
- Click the [Query] button to query the logs within the specified time range.
- When there are many logs, you can use [First Page], [Pre Page], [Next Page], [Last Page] in the lower right corner to turn pages to view the logs, or enter the page number to view directly in [Jump To] to jump to the specified page.
- Click [Export Current Page] to export the log of current page to PC.
- Click [Export All Page] to export all the logs found to the PC.

## 5.7 Configuration

After login, [ Live View ] will be displayed by default. Click [Configuration] in the menu bar at the top of the page to enter the parameter configuration page, where you can set common settings, audio and video parameters, network settings, intelligent analysis, storage settings and system settings.

**Note:** Because different models support different functions, the interfaces and menus may also be different, please refer to the actual interface

### 5.7.1 Basic Set

The screenshot displays the 'Basic Set' configuration page, organized into several sections:

- Network:** Includes a checkbox for DHCP. Fields for IPv4 Address (192.168.15.181), IPv4 Subnet Mask (255.255.255.0), Gateway (192.168.15.1), and DNS (192.168.15.1). Fields for HTTP Port (80) and RTSP Port (554).
- Video:** A table for configuring video streams:

	Resolution	Video Encoding	Encoding Mode	Frame Rate	Bit Rate
1st	5MP(3072x1728)	H.265	VBRGood	20	1024
2nd	4CIF(704x480)	H.264H	VBRNormal	20	1024
3rd	CIF(352x240)	H.264B		20	512
- Audio:** Fields for Audio Encoding (ADPCM\_D), Audio Sample Rate (8kHz), and a Volume Value slider set to 78.
- OSD:** Checkboxes for Camera Title and Date. The Date field is set to Apr 01 2020.
- Motion:** A checkbox for 7x24Full Area and a Sensitivity slider set to 76.
- Users:** A table listing users:

No.	User Name	Authority	Edit	Delete
1	Admin	Admin	Edit	

At the bottom, there are buttons for Save, Cancel, Import, Export, Basic Re..., and Reboot.

Fig.5.7.1.1 Basic Setting interface

#### Basic Set - > Network

- [DHCP]: When checked, the DHCP server will automatically assign IP to the device.
- [IPv4 Address]: Set the IP address of the device.
- [IPv4 Subnet Mask]: Set the subnet mask of the device.
- [Gateway]: Set the gateway of the device.

- 
- [DNS]: Set the DNS server address.
  - [HTTP Port]: Enter [HTTP port number] in the input box on the page, restart the device, and then modify the HTTP port number.
  - [RTSP Port]: Enter [RTSP port] in the input box on the page, restart the device, and then modify the RTSP port number.
  - [More...]: Click  to jump to the network setting interface.

### Basic Set - > Video

- [Resolution]: Select the necessary resolution in the drop-down list of [Resolution] and the code stream will be switched to the designated resolution.
- [Video Encoding]: Select appropriate video encoding mode in drop-down list, such as [H.264], [H.265], etc.
- [Encoding Mode]: It can be set as [Constant Bit Rate] or [Variable Bit Rate]. Under the mode of constant bit rate, the video data size fluctuation is small and the bandwidth is stable during network transmission. Under the mode of variable bit rate, the video data size changes with the video image complexity, and the bandwidth can be saved in single scene.
- [Frame Rate]: Select the needed frame rate in the drop-down list; stream will switch to designated frame rate. (Frame rates supported by different N/P Mode and resolutions are slightly different, please refer to actual product)
- [Bit Rate]: Select the necessary resolution in the drop-down list of [Resolution] and the code stream will be switched to the designated [Bit Rate]. (Unit: kbps)  
**Note:** Select the necessary resolution in the drop-down list of [Resolution] and the code stream will be switched to the designated resolution.
- [More...]: Click  to jump to the network setting interface.

---

### Basic Set - > Audio

- [Audio Encoding]: Set the audio coding mode
- [Audio Sample Rate]: Set the audio sampling rate
- [Volume value]: Can adjust the output sound, range is 100 ~ 0, The smaller the value of the device output audio signal amplitude is smaller; The greater the number of devices output audio signal amplitude is greater.
- [More...]: Click  to quickly jump to audio settings

### Basic Set - > OSD

- [Channel Title]: Set the character overlay name of the channel. If it is checked, it means display; if it is not checked, it means display
- [Date]: Select the check box of [date and time] to overlap the date and time on the screen
- **Note:** If you select the check box, the information will be overlapped on the screen.
- [More...]: Click  to quickly jump to character overlay settings

### Basic Set - > Motion

- Set [7x24Full Area] to enable motion alarm.
- [Sensitivity]: Set the motion alarm sensitivity.

### Basic Set - > Users

[New]

To add a new user, you need to set the user name, password and permission. The user name and password can only be entered in English letters and numbers. After the above three items are filled in, click the [Save] button.

**Note:** only users with administrator rights can add and modify users.



---

### [Edit]

In the user list, click [Edit] to open the password modification prompt box, input the old password, new password and confirm the password, and then click Modify.

### [Remove]

In the user list, click [Remove] to open the prompt box and click OK

### **Basic Set - >Other buttons**

- Click the [Save] button to save and make it take effect.
- Click [Cancel] to restore the last saved parameter.
- [Import]/ [Export]: Used for equipment maintenance, mainly divided into three categories:
  - [Event Server] options include alarm time period and linkage item setting information, excluding intelligent analysis.
  - [Smart Analytics] options include settings related to intelligent analysis, including rules, time periods, etc.
  - [System Setting] options include all setting information except the above alarm and intelligent analysis, including character superposition, video recording strategy, network setting and other information.
- [Basic Reset]: Restore the default parameters of the device. (key information such as IP address will not be recovered)
- [Reboot]: Restart the device.

## 5.8 Audio Video Set

### 5.8.1 Stream

#### Stream- > Stream

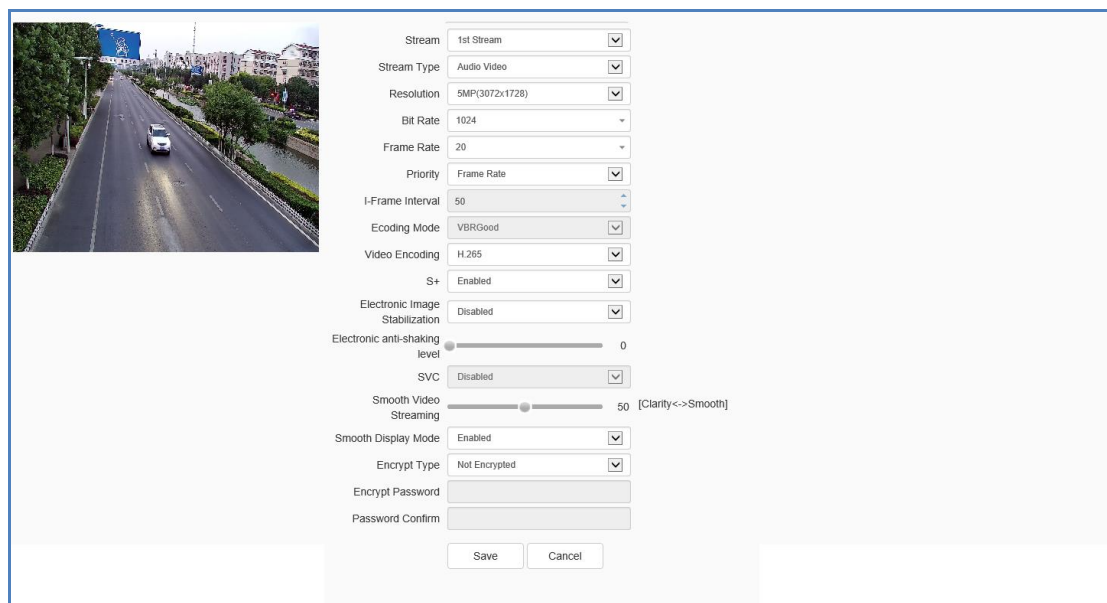

Fig.5.8.1.1 Stream - Stream interface

Related parameters of video configuration are illustrated as follows:

Parameters	Description
Stream	The video related parameters of the main stream, the sub stream and the third stream can be modified. Select the corresponding code stream of the family and modify the parameters of the corresponding code stream
Stream Type	You can choose pure video or audio video.
Resolution	Set the resolution of the video. (different models are compatible with different maximum resolutions).
Bit Rate	Set the bit rate of the video in KB / s. Code rate range: 32 ~ 16384kb / s.

	<p>Tip: select the required resolution from the [resolution] drop-down list, and the code stream can be switched to the specified [code rate]. When [compression method] is [constant rate], the [code rate] represents the actual code rate of the code stream; when [compression method] is [variable rate], the [code rate] represents the maximum allowed code rate of the code stream.</p> <p>(Different models support different code rates, please refer to the actual interface)</p>
Frame Rate	<p>Sets the frame rate of the current video. In the [PAL] system, some models support 50 frames, and the maximum support is 25 frames when the wide dynamic mode is turned on. [NTSC] under the system, some models support 60 frames, and when the wide dynamic mode is turned on, the maximum support is 30 frames.</p>
Priority	<p>The video set to [frame rate first] is smoother and the video set to [quality first] is clearer.</p>
I-Frame Interval	<p>The number of frames between every two I frames can be set, and the range can be 10-100.</p>
Encoding Mode	<p>Set constant rate or variable rate compression. At the fixed bit rate, the amount of video data fluctuates little, and the bandwidth occupied by the network transmission is stable; at the variable bit rate, the amount of video data changes with the complexity of the video picture, and the bandwidth is saved when the scene is single. In the case of variable bit rate, there are several levels. If the better, the higher the average bit rate is.</p>
Corridor Mode	<p>The screen is rotated 90 degrees to adapt to the scene where the device is installed on the wall. It is off by default.</p>
Video Encoding	<p>Set how video is encoded. H. 265 encoding saves bandwidth, but</p>

	some browsers or playback software do not support h.265.
S+	Switch S + on and off can be selected from the drop-down list. When S + is enabled, functions such as compression mode, video quality, I-frame frame rate and key area will not be available.
Electronic Image Stabilization	According to the actual situation, user can select [On] or [Off] to optimize the picture quality and prevent shake. (Supported by some models)
Electronic anti-shaking level	According to the actual situation, user can select [On] or [Off] to optimize the picture quality and prevent shake. (Supported by some models)
SVC	When [SVC] is turned on, P frame can be encoded as non reference frame, which can be used for frame extraction video recording and save storage space. The video file after frame extraction still supports normal decoding. When the [auto] mode is selected, the device will adapt to the current network environment and decide whether to send the frame to ensure that the image can be previewed normally during preview. (supported by some models)
Smooth Video Streaming	The ratio of I frame and P frame can be set. The closer to smoothness, the better the smoothness of dynamic scene, the closer to clarity, and the better the video clarity performance of static scene.
Smooth Display Mode	Set whether to turn on unobstructed mode. (supported by some models)
Encrypt type	According to the situation, users can encrypt video data to improve the security of network transmission. [Encrypt type] select the required encryption algorithm (currently only AES algorithm is

available), [Encrypt password] set the encryption password, and [password confirmation] input the encryption password again to ensure that the password entered twice is the same. Click [Save] to take effect.

After setting, click Save to take effect. Click [Cancel] to discard the changes.

### Stream - > ROI (Key Area Interface)

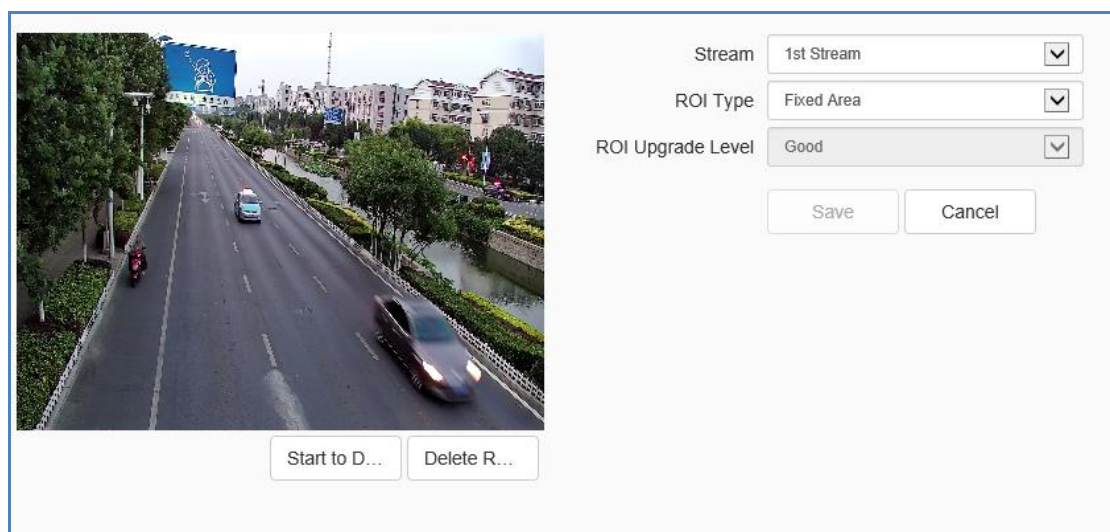

Fig.5.8.1.2 Video parameters key area interface

After the front-end connection supporting the key area setting, you can set the key area here. The image quality displayed in the focus area is higher.

- Click the "Start to Draw" button to drag the video by holding down the left mouse button, and then you can set the key area. Several key areas can be set up. Click "Delete Region" to delete all the key areas that have been set.
- Click [Save] to save the corresponding parameter settings. Click [Cancel] to restore the last saved parameter
- [Stream]: Select stream which needs to be set in [Stream] drop-down list.
- [ROI Type]: Select the desired [ROI Type] from the drop-down list. If you select Dynamic, select the [Enabled] check box.

- [ROI Upgrade Level]: According to actual needs, set image quality of key region, such as [Best], [Better], [Good], [Normal] and [Poor], etc.

**Note:** After adjusting the resolution, video coding and other options, you need to adjust the code rate, compression coding and other parameters according to the actual image effect.

## 5.8.2 Audio

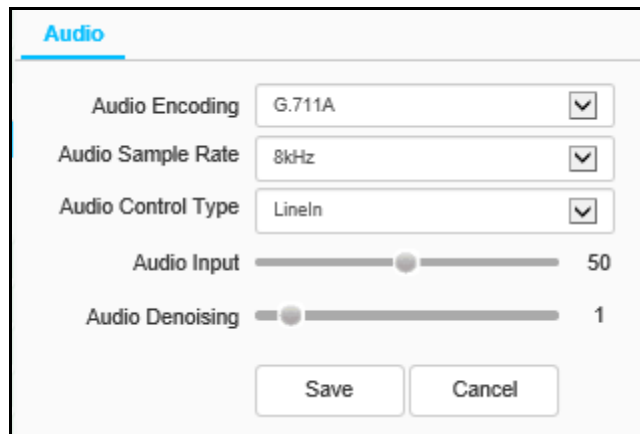

Fig. 5.8.2.1 Interface of audio parameter setting

You can modify the audio coding mode, audio sampling rate, audio control types, volume values, audio noise levels and other parameters.

Parameters	Description
Audio Encoding	Set the audio encoding mode of the bit stream.
Audio Sample Rate	Sets the audio sampling rate for the bit stream.
Audio Control Type	It supports two modes: LineIn and MicIn. The control mode needs to be selected according to the output signal amplitude of the external audio equipment. When the external mic small signal (mv level signal) is connected, please select MicIn; when the external equipment is the active audio equipment (V level signal), please select LineIn mode. (supported by some models)

---

Audio Input	The input sound size can be adjusted, and the adjustment range is 0-50. The smaller the value is, the smaller the input audio signal amplitude of the device is; the larger the value is, the larger the input audio signal amplitude of the device.
Audio Denoising	The filter level of environmental noise can be set. The default level is 1. When the value is 0, turn off the audio noise reduction function. (supported by some models)

After setting, click Save to take effect. Click [Cancel] to restore the last saved parameter.

**Note:**

- To modify the audio parameters, the intercom function needs to be turned off.
- Modify the audio coding mode and audio sampling rate parameters.

### 5.8.3 Image Setting

#### Image Setting->Image

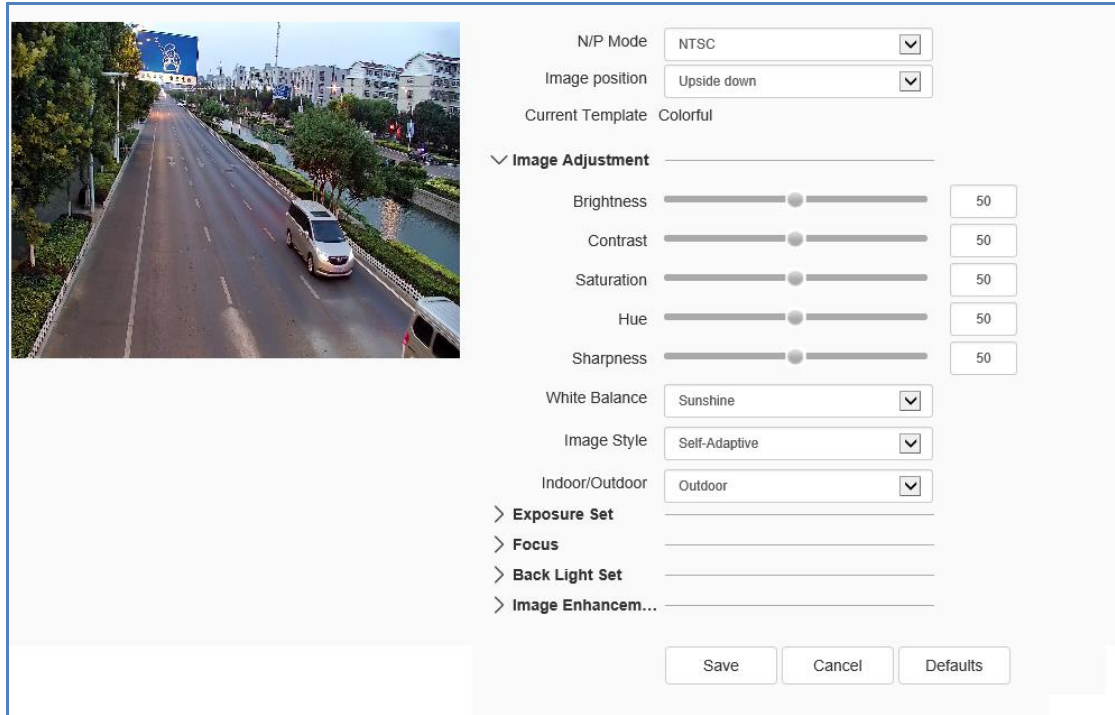



Fig.5.8.3.1 Image interface

### Image - Template Selection

- [N/P Mode]: Select the needed N/P Mode in drop-down list of [N/P Mode]. It can be set as [PAL] or [NTSC].
- [Image Position:] Select the method to display image mirror in [Image Position].
- [Current Template]: Displays the type of template used.

### Image -Image Adjustment

Click the  button next to [Image Adjustment] to expand the [Image Adjustment] interface.

Set the brightness, contrast, saturation, hue, sharpness, white balance, image style and indoor/ outdoor modes of the picture through the image adjustment menu.



---

## Image –Exposure Set

Click the  button next to [Exposure Set] to expand the [Exposure Set] setting interface.

Parameters	Description
SmartIR	It is mainly used for infrared night vision model. When the overexposure scene appears in the picture, the camera will automatically reduce the brightness if this function is turned on to avoid unclear objects due to overexposure.
Exposure Mode	There are automatic / manual / shutter priority / aperture priority. In “auto” mode, aperture, shutter and gain are adjusted automatically; in “manual” mode, shutter, aperture and gain adjustment can be set manually; in “shutter priority” mode, shutter size is adjusted manually, and other parameters are adjusted automatically; in “aperture priority” mode, aperture size is adjusted manually, and other parameters are adjusted automatically.
Max Exposure Time	We can calculate the minimum exposure time to eliminate blur and maximize our scene brightness , the range is 1/100 K to 1
Minimum Exposure Time	We can calculate the minimum exposure time to eliminate blur and maximize our scene brightness , the range is 1/100 K to 1
Max Aperture Set	Aperture, measured in F numbers, is the camera's ability to gather light. The lower this F number is, the larger the lens Aperture will be, the more open your lens, and the better it will be at allowing light to pass through and onto the mage sensor. Range F 1.6 to F 14.0

Max Gain Set	Adjusting the maximum gain value can compensate the picture of brightness under low illumination. The larger the gain value is, the higher the brightness will be, but the greater the noise will be
Brightness	Set up the desired Fig. Brightness value.
Auto Exposure Speed	Adjust the scroll bar to set up the exposure sensitivity. The larger the value is, the faster the exposure response will be when the scene changes.

## Image –Focus

Click the  button next to [Focus] to expand the [Focus] setting interface.

Parameters	Description
Focus mode	[Auto] / [Manual] / [Semi-auto] are optional. Under the [Auto] mode, focus automatically according to the monitoring scene. Under the [Manual] mode, focus clearly and manually by focusing on the preview interface. Under [Semi-auto] mode, one PTZ action triggers one focus, and there is no automatic focusing when the same scene image changes.
Min focus distance	The minimum focusing distance can be set, and it can be set as 6m for the outdoor large-scale scene and 1.5m for the indoor scene.

---

## Image –Back Light Set

Click the  button next to [Backlight] to expand the [Backlight] setting interface.

Parameters	Description
HLC	<p>It is mainly used in road monitoring scenes.</p> <p>It can suppress the glare such as car headlights after being turned on, thus reducing the effect of glare.</p>
WDR	<p>Select the option for WDR from the drop-down list. The options are [WDR Auto], [WDR Manual], [Close] and [Backlight compensation].</p> <p>Select [WDR Auto] or [WDR Manual] to display the [super wide dynamic grade] slider. Drag the slider to set the level that meets the requirements of the scene. The larger the value, the more obvious the effect.</p> <p>Select [backlight compensation] and check [Set Apheliotropic Area] and click Save to set light compensation and improve the brightness in the setting area</p>

## Image - Image Enhancement

Click the  button next to [Image Enhancement] to expand the [Image Enhancement] setting interface.

Parameters	Description
Defog	Select [Enabled], [Disabled] and other options according to actual needs.
Defog Strength	Drag the slider to set the desired value.
Digital Noise Reduction	In the drop-down list, you can select [close], [ordinary

mode] and [expert mode]. Select [ordinary mode], display the [denoise level] slider, drag the slider to set the noise reduction level. Select [expert mode], and the sliders of [space denoise level] and [time denoise level] will pop up respectively. Drag the two sliders to set [airspace noise reduction level] and [time domain noise reduction level] respectively.

After the HD parameters are set, click [Save] to save.

Click [Cancel] to restore the last saved parameter.

[Defaults]: The parameters of each template can be restored to the default settings.

**Image settings - > Schedule**



Fig.5.8.3.2 Schedule interface

Users can use different templates for equipment at different time periods by means of using HD template, to ensure that the effects of videos are the best in different time periods.

- [Day]: Set the HD template during the day.
- [Night]: Set the HD template at night.
- Click the [Save] button to save and make it take effect.

## Image settings - > Day/Night

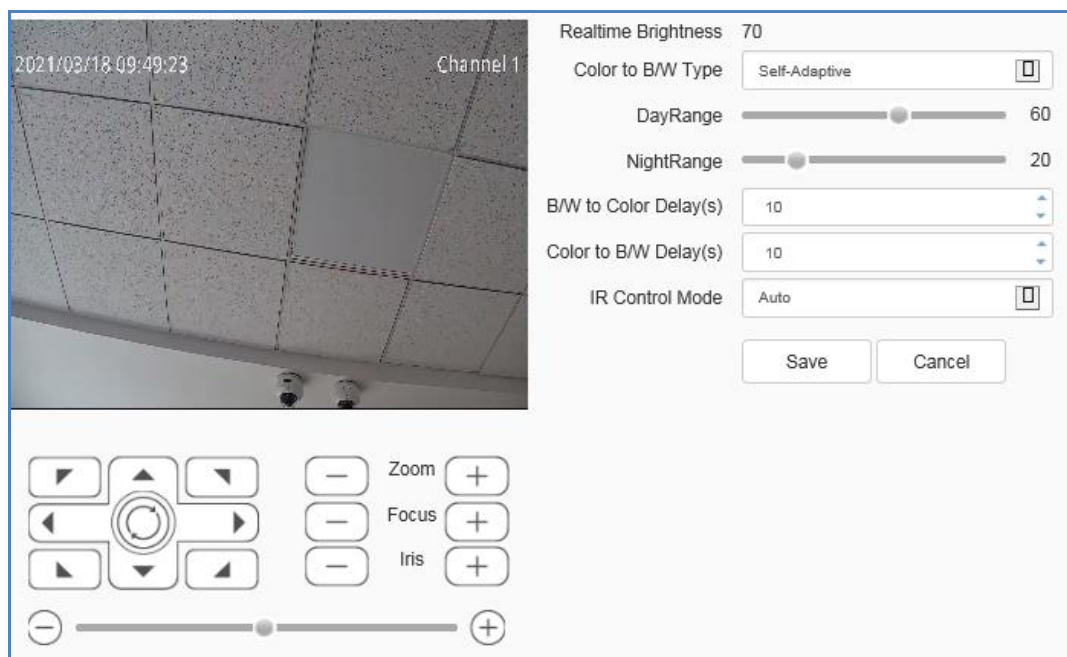

Fig.5.8.3.3 Day/Night setting interface

Parameters	Description
Color to B/W Type	<p>It can be set as color, B/W, Schedule or Self-Adaptive.</p> <p>[Black and White]: The device video is always in black and white mode.</p> <p>[Color]: The device video is always in color mode.</p> <p>[Schedule]: In the timing mode, users can specify the dawn time and dark time.</p> <p>[Self-Adaptive]: The device automatically switches between black and white or color mode according to the scene.</p>
Sunrise Time	Under the Schedule template, the timing from black to color can be set.
Sunset Time	Under the Schedule template, the timing from color to black can be set.

DayRange	When it is set to Self-Adaptive template, you can set up the brightness point of black to color conversion. (when it is higher than the brightness value in the daytime, it turns to the daytime mode)
NightRange	When it is set to Self-Adaptive template, you can set up the brightness point of color to black conversion. (when it is lower than the brightness value in night-time, it turns to night-time mode)
Black-to-color Delay	When it is set to Self-Adaptive template, when the daytime brightness value is reached, how long is the delay, the device changes from black and white to color.
Color to black Delay	When it is set to Self-Adaptive template, when the brightness value of night and night is reached, how long is the delay, the device changes from color to black and white.
IR Control Mode	Set the mode as Auto or Manual.

#### 5.8.4 OSD

#### OSD->OSD

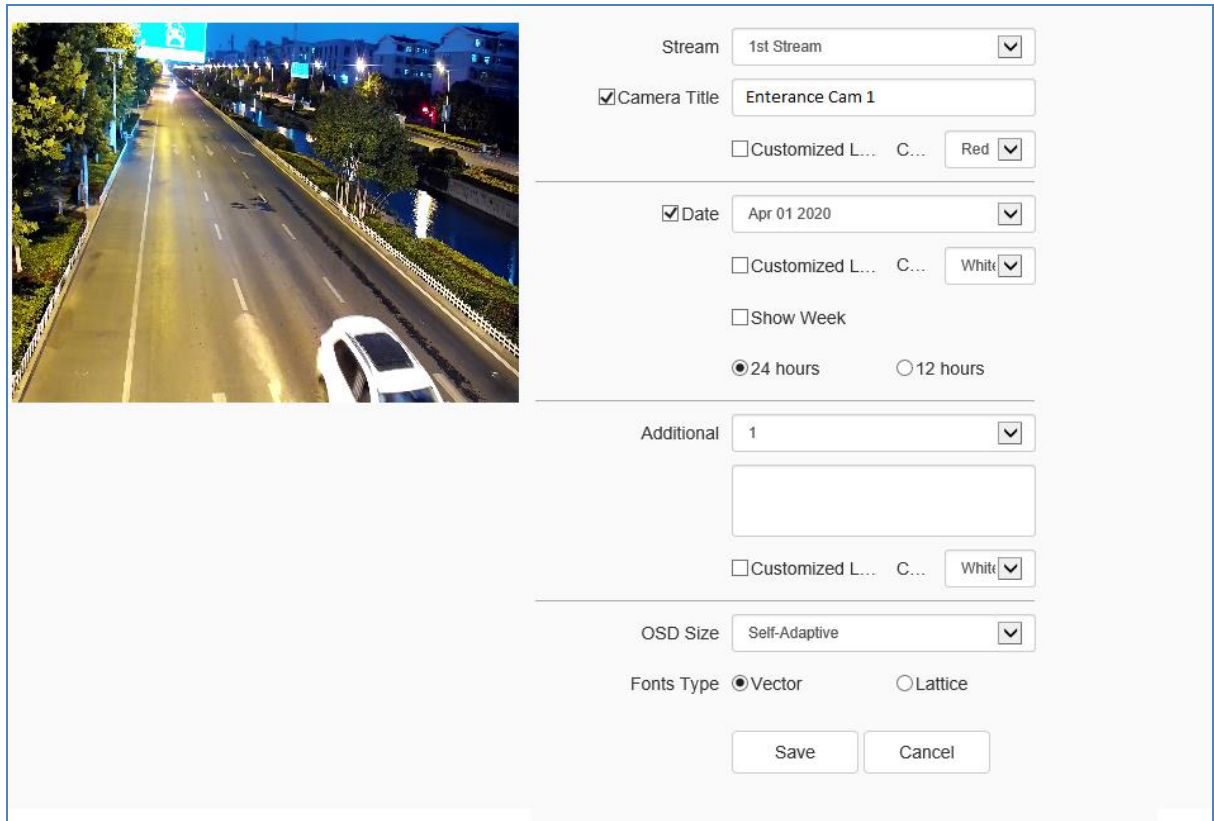

Fig.5.8.4.1 OSD Interface

[Stream]: Select the code stream to stack character information.

### [Channel Title]

- Select the [Channel Title] check box to overlay the channel name on the screen.
- Enter a name in the input box on the right to set the channel name.
- From the [Color] drop-down list, select the color you like for the superimposed content.
- If you need to change the position of the superimposed character, select the [Customized Location] check box, and click on the small screen with the mouse to specify a new position for the superimposed character.

### [Date]

- Select the [Date] check box to overlay the date and time on the picture.
- Select your preferred date format from the drop-down list on the right.
- If you need to include the week in the displayed time and date, select the

---

[Show Week] check box.

- As required, the time can be displayed in 24-hour or 12-hour mode. Select the corresponding option from the 2 buttons below.
- From the [Color] drop-down list, select the color you like for the superimposed content.
- If you need to change the position of the superimposed character, select the [Customized Location] check box, and click on the small screen with the mouse to specify a new position for the superimposed character.

### **[Additional]**

- [Additional] at present, there are 5 areas for stacking.
- Input the text content to be superimposed from the input box below, including Chinese characters, English and common punctuation marks. You can stack multiple lines of content in one area as needed. Some models support peripheral mode. Click [insert] to add peripheral information.
- From the [color] drop-down list, select the color you like for the superimposed content.
- Select the [Customized Location] check box and click on the small screen with the mouse to specify a new location for the superimposed characters.

### **[OSD Size]**

- You can specify the size of the superimposed characters, select the preferred character size (unit: pixel) in the [OSD Size] drop-down list, or select [Self-Adaptive] to let the system automatically adjust the character size.
- [Font Type]: Select the [Font Type] as Vector or Lattice.

After all the above parameters are set, click [Save ]to save and take effect; click [Cancel] to restore the last saved parameters.



## OSD->LOGO

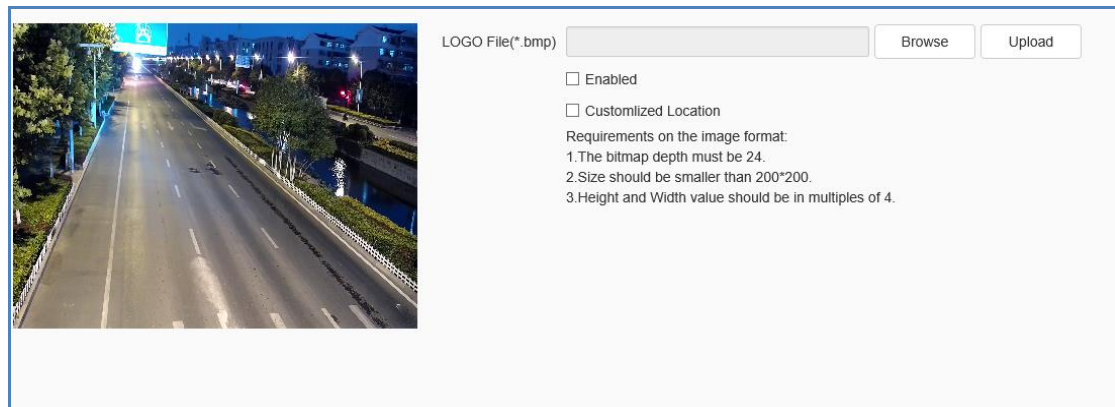

Fig.5.8.4.2 OSD-LOGO

- Enter the path of the image file in the [LOGO File] input box, or click the [Browse] button to find the image file in the pop-up window.
- After clicking the [Upload] button, the picture will be uploaded to the equipment, and the equipment will restart automatically after uploading the picture.
- After the equipment restarts, select the [Enable] check box to overlay the LOGO picture on the video. If the [Enable] check box is canceled, the LOGO will not be displayed.
- With [Enable] selected, select the [Customized Location] check box and click on the video screen with the mouse to specify a new display location for the LOGO.

### Note:

- The LOGO picture must be a bitmap file in bmp format. The bitmap depth is 24, the size is smaller than 200 \* 200 pixels, and the height and width are divisible by 4. Please use a picture that meets the requirements.
- Overlapped LOGO will automatically remove its black and white background.

## OSD- > Privacy Mask

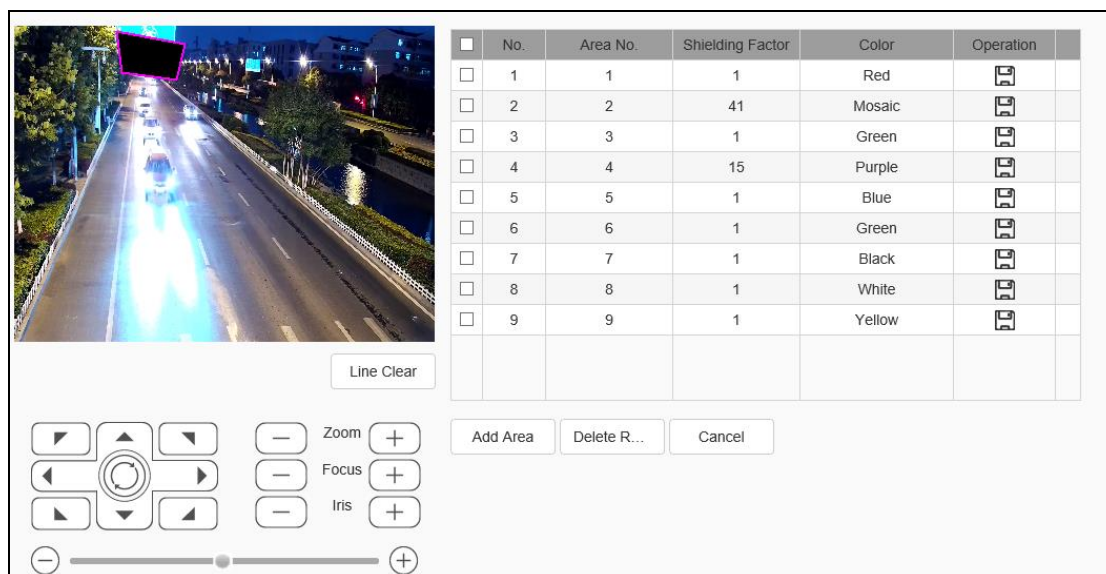

Fig.5.8.4.3 Privacy Mask setting interface

According to the user's needs, Shelter area can be set up on the picture according to the user demand to protect key information from being seen. 24 shelter areas can be set up at most for each equipment.

- Draw up the area to be sheltered in the small preview window.
- Click [Add Area] button.
- Click [Shielding Factor] and set up the magnification value, only when the variable magnification value is greater than the shielding magnification, the private shelter area will display, or it will not display.
- Click [Color], to select the desired color to be set.
- Click the Save icon under Operations.
- If the user wants to delete the shelter area, click the check box before the serial number to select corresponding shelter area, then click [Delete Region] button to delete the area.

## 5.9 Dome Set

The specific parameters displayed depend on the specific model of the dome camera. Please refer to the actual manual.

## 5.9.1 Basic Set

### Basic Set ->Basic Information

The screenshot shows a configuration window titled "Basic Information". At the top, there are four checkboxes:  Auto Flip Enable,  Preset Freeze...,  Digital Zoom, and  Preset Snaps... Below these are another four checkboxes:  Proportion Zo...,  Scan Record...,  Mode Record..., and  RS485 control... The main area contains several settings, each with a label and a control element: "Control Speed" with a dropdown menu set to "Mid"; "Zoom Speed Level" with a dropdown menu set to "High"; "Temperature Control..." with a dropdown menu set to "Auto Scan"; "Auto Stop-time(s)" with a dropdown menu set to "30"; "Preset Speed" with a dropdown menu set to "Mid"; "P/T First" with a dropdown menu set to "Network"; "Priority Delay Time(s)" with a slider bar set to "0"; "Standby Action" with a dropdown menu set to "Preset1" and an  Enabled checkbox; "Standby Time" with a dropdown menu set to "30"; and "Power-lost Memory..." with a dropdown menu set to "1Minute". At the bottom of the window are two buttons: "Save" and "Cancel".

Fig.5.9.1.1Basic Information

- [Auto Flip Enable]: When the perpendicularity of the dome camera is 90°, the dome camera will rotate horizontally by 180° if moving along the original direction continuously.
- [Preset Freeze Enable]: During the calling of preset, the image will stop at the preset all the time without showing the image during the calling and will come back when reaching the calling preset.
- [Enable Digital Zoom]: After starting, when the optics variable magnification reaches to the maximum, continue to click the variable magnification to start digital variable magnification.
- [Enable Preset Snapshot]: After starting, it will capture pictures during the calling preset and save them in the front-end storage medium.

- 
- [Enable Proportion Zooming]: It will adjust the operating speed automatically with the variable magnification figure after starting; if not, all zooming speed is the same, so it is better to start.
  - [Enable Scan Record]: After starting, it will record during scanning, and the video files will be stored in the front-end storage medium.
  - [Enable Mode Record]: After starting, it will record during the mode path, and the video files will be stored in the front-end storage medium.
  - [Enable RS485 Control Gimbal]: Enable the camera and 5880/5820 network keyboard to control the operation of the dome camera through RS485 control line.
  - [Control Speed]: The control speed level includes high, medium and low levels, and the maximum speed of the PTZ can be changed by modifying this item.
  - [Zoom Speed Level]: The variable magnification speed level includes high, medium and low levels, and the variable magnification speed can be changed by modifying this item.
  - [Temperature control mode]: [Auto], [OFF] and [FOG] are optional.
  - [Auto stop time (s)]: The auto stop time refers that the dome camera will stop the PTZ from working if it fails to receive the stop code for a long time, and it can be 5s, 15s, 30s and 60s.
  - [Preset speed]: The preset speed level includes high, medium and low levels, and the preset speed can be changed by modifying this item.
  - [P/T First]: There are two options including network and RS485. Select the PTZ priority control mode according to specific needs.
  - [Priority Delay Time (s)]: Delay time between two control modes. For example: The setting time is 30s; when selecting the network for the PTZ priority mode, RS485 cannot control the dome camera within 30s after the network control.
  - [Standby Action]: Select the [Enable] option button behind the standby action to set the standby action. The standby action includes four options

---

such as preset 1, scanning 1, cruise 1 and mode 1. Click the save button to save setting after modifying the standby action.

- [Standby time (s)]: Select the [Start] option button behind the standby action to set the standby time. The standby time includes 30, 60, 300, 600 and 1800. Click the save button to save setting after modifying the standby action.
- [Power-lost memory mode]: Save the PTZ position time automatically. After power on again, the dome camera will return to the PTZ position saved last time.

### Basic Set ->Title

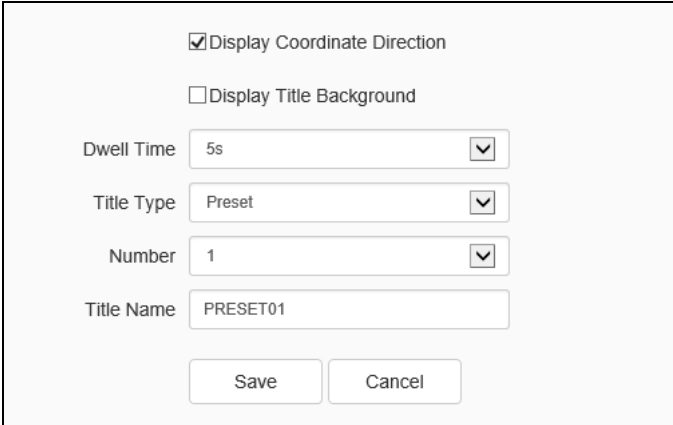

The screenshot shows a configuration window for setting titles. It contains the following fields and controls:

- Display Coordinate Direction
- Display Title Background
- Dwell Time: 5s (dropdown menu)
- Title Type: Preset (dropdown menu)
- Number: 1 (dropdown menu)
- Title Name: PRESET01 (text input)
- Buttons: Save, Cancel

Fig.5.9.1.2 Title setting interface

- [Display Coordinate Direction]: When checking the option button [Show coordinate direction], the dome camera coordinate will be shown after operation; when canceling the checking, the coordinate direction will not be shown.
- [Display Title Background]: When checking [Show title background], the action title should have background color during the operation of the dome camera; when canceling the checking, the action title should not have a background color.
- [Dwell Time]: Set the title standing time (such as close, continue, 2s, 5s and 10s).
- [Title No.]: Select the title number, wherein the preset number range 1-32,

---

the scanning number range 1-8, the cruise number range 1-16, the mode path number range 1-8 and the regional instruction number range 1-8.

- [Title Type]: Preset, Auto Scan, Auto cruise, Mode and Zone are optional.
- [Title Name]: Set the title name.

## 5.9.2 Motion Set

### Motion Set->Motion Set

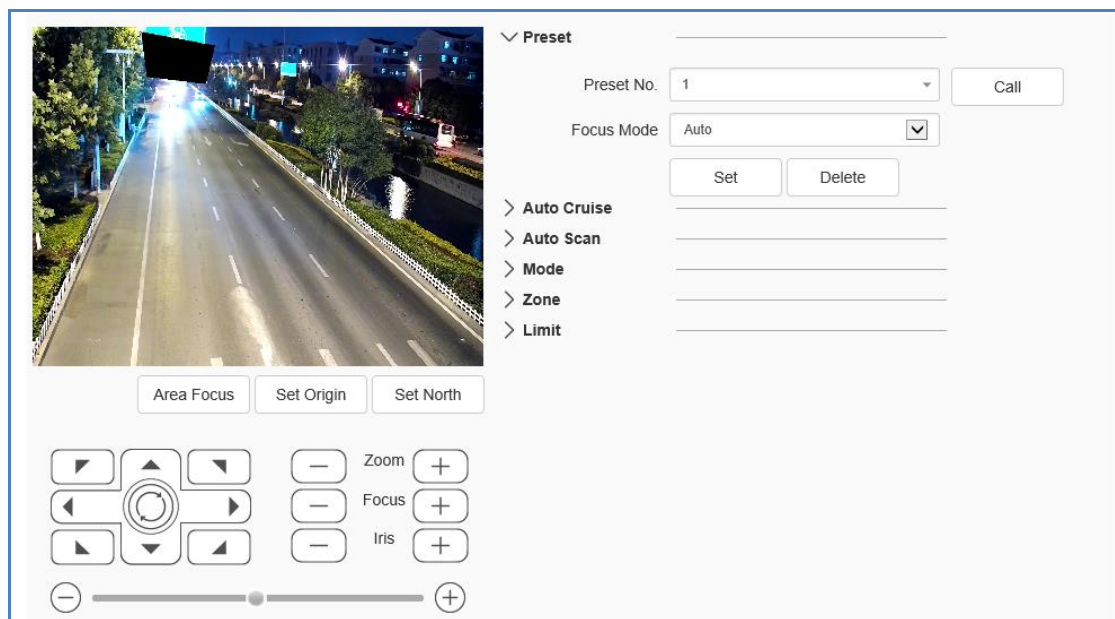

Fig.5.9.2.1 Motion Set Interface

- [Area Focus]: The user can operate the dome camera by clicking Area Focus to select an area to focus when the desired position is reached.
- [Set Origin]: The user can operate the dome camera, click [Set Origin] after reaching to an expected position and select an orientation zero.
- [Set North]: The user can operate the dome camera, click [Set North] after reaching to an expected position and select a heading to north.

### Motion Set - Preset set

- [Preset No.]: The dome camera can support 500 preset totally, wherein the non-special preset includes 1-64 and 100-500, and the user can set these preset.

- 
- [Focus Mode]: The focusing mode of the preset can be automatic and fixed.
  - [Set]: The user can operate the dome camera and click [Set] to store it at the current position when reaching to an expected position.
  - [Delete]: Click [Delete] to delete the preset of the corresponding number.
  - [Call]: Click [Call] to call the preset of the corresponding number.

### **Motion Set - Auto cruise set**

- [Cruise No.]: The dome camera can support 16 automatic cruise numbers (1-16) totally. Select the desired number and click Add [ + ]. The entry appears in the table. You can edit the Preset and Retention Time.
- [Preset]: Click to select 1-64 and 100-255 preset, click [Save] button.
- [Retention time (s)]: The standing time of corresponding preset can be set as 1-60. Click to edit the time.
- Add [+]: Click to add corresponding preset to the cruise list of the current automatic cruise number.
- Minus [ - ]: Click to delete corresponding preset to the cruise list of the current automatic cruise number.
- Click up / down arrow to change the sequence.
- [Call]: Click [Call] to operate automatic cruise of corresponding automatic cruise number.

### **Motion Set - Auto scan set**

- [Scan No.]: The dome camera can support 8 automatic scanning (1-8) totally.
- [Scan type]: The scanning type includes Pan Scan, Auto Scan, Frame Scan, Random Scan, Tilt Scan, Full Scan and Spiral Scan.
- [Scan speed]: Change the speed of Pan Scan, Auto Scan, Tilt Scan, Full Scan and Spiral Scan by changing the scanning speed.
- [Border 1]: The user can operate the dome camera and click [Border 1] to

---

store the current position as the scanning route left boundary after reaching the expected position.

- [Border 2]: The user can operate the dome camera and click [Border 2] to store the current position as the scanning route right boundary after reaching the expected position.
- [Call]: Click [Call] to scan corresponding automatic scanning number.

### **Motion Set - Mode path setting**

- [Mode No.]: The dome camera can support 8 mode paths (1-8) totally.
- [Used(%)]: Show the percentage stored and used when recording the mode path.
- [Left Time(s)]: Show the rest time when recording the mode path (the dome camera can support 600s record at most).
- [Record]: Click [Record] to record the mode path, then the user can operate the dome camera, and the dome camera can record the user's operation.
- [Delete]: Click [Delete] to delete the mode path of the corresponding mode route number.
- [Call]: Click [Call] to operate the mode path of the corresponding mode route number.

### **Motion Set - Zone set**

- [Zone No.]: The dome camera can support 8 regional instructions (1-8) totally.
- [Left Border]: The user can operate the dome camera and click [Left Border] to store the current position as the regional instruction left boundary after reaching the expected position.
- [Right Border]: The user can operate the dome camera and click [Right Border] to store the current position as the regional instruction right boundary after reaching the expected position.



- [Delete]: Click [Delete] to delete the regional instruction of corresponding regional instruction numbers.

### Motion Set - Limit set

- [Enable Limit]: After checking, the movement area of the dome camera will be controlled in the limit area.
- [Set]: Clicking the set button, the left preview window will show the prompt information: Set the upper/lower/left/right limit according to the prompt information; if you want to set horizontal limit rather than vertical limit, set the upper and lower limits at the same position.
- [Delete]: Delete the set limit.

### Motion Set->Motion Schedule

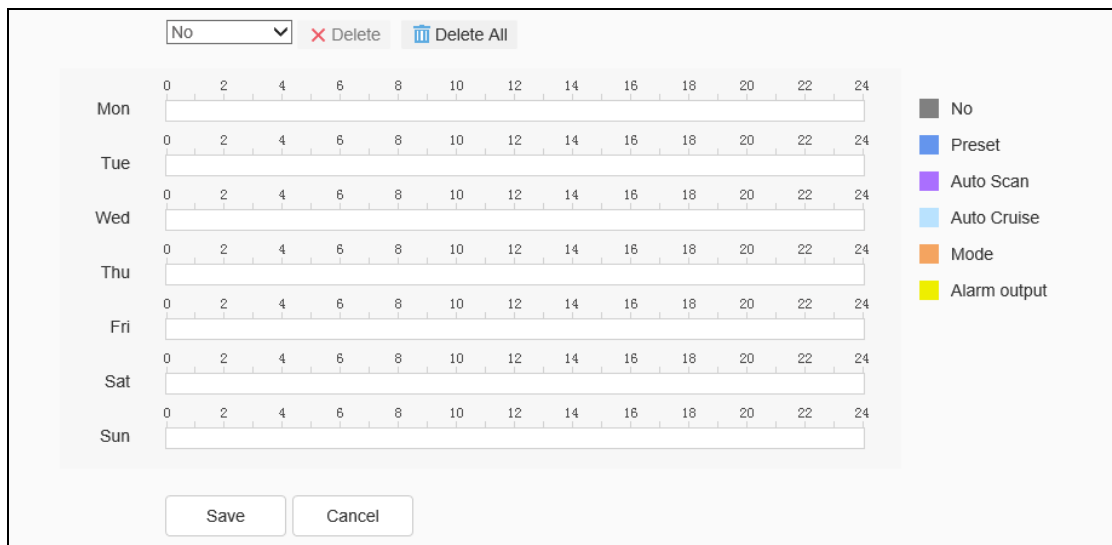



Fig.5.9.2.2 Motion Schedule Interface

Refer to complete the presetting functions in the time period specified by the user. These functions include preset, auto scan, auto cruise, mode and alarm output.

Click the [Save] button to save the effect.

Click the [Cancel] button to restore the last saved parameter.

Click the Copy to.  green icon on the right, to copy the settings to other days

---

of the week. [Click Confirm].

### 5.9.3 Remove Config

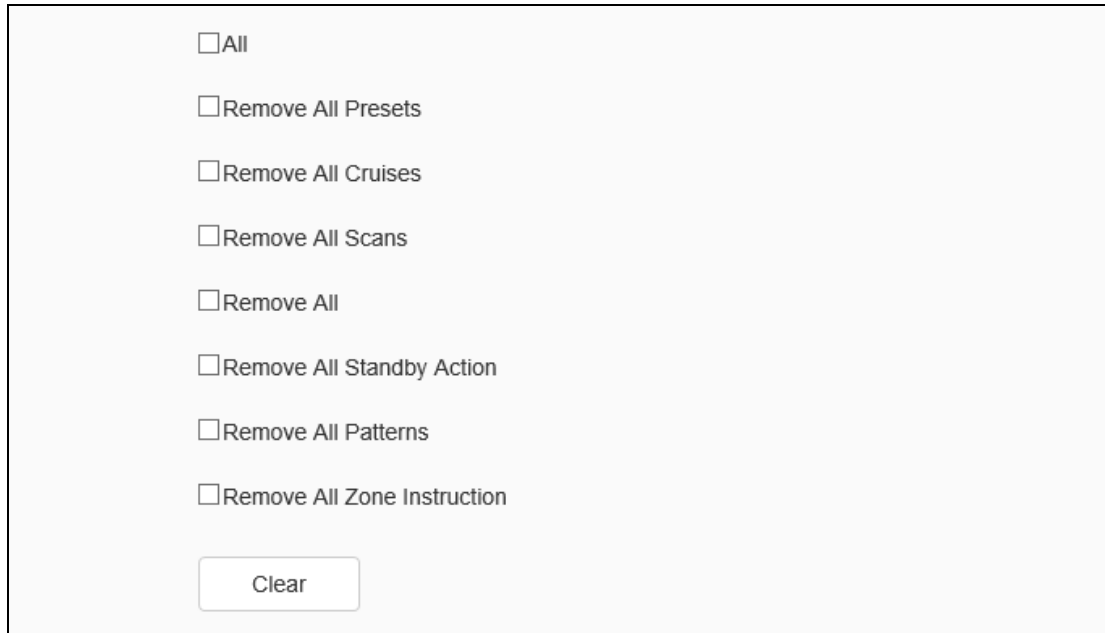

The screenshot shows a configuration interface with the following elements:

- All
- Remove All Presets
- Remove All Cruises
- Remove All Scans
- Remove All
- Remove All Standby Action
- Remove All Patterns
- Remove All Zone Instruction

At the bottom of the list is a button labeled "Clear".

Fig.5.9.3.1Remove Config

In the configuration clear interface, including select all, clear all preset, all cruise route, all scanning, all location limitation settings, standby operations, all mode path, all regional instructions, select the items to be cleared, click the clear button to clear the corresponding PTZ configuration.

## 5.10 Network

### 5.10.1 Basic Set

**Basic Set->TCP/IP**

MAC 00:50:c2:2a:1d:df

▼ IPv4 setting

DHCP

IPv4 Address 192.168.15.181

IPv4 Subnet Mask 255.255.255.0

Gateway 192.168.15.2

Auto Get DNS

DNS 192.168.15.2

Alternate DNS 192.168.1.1

> IPv6 setting

> Other

Save Cancel

Fig.5.10.1.1.1 IPv4 setting interface

MAC 00:50:c2:2a:1d:df

> IPv4 setting

▼ IPv6 setting

IPv6 mode DHCP

Link local address fe80::250:c2ff:fe2a:1ddf/64

IPv6 Address fdae:5ddd:f720::6f8 View IPv6 a...

IPv6 subnet prefix len... 64

IPv6 default gateway fe80::8eab:8eff:fed8:1409

Auto Get DNS

DNS fdae:5ddd:f720::2

Alternate DNS

> Other

Save Cancel

Fig.5.10.1.1.2 IPv6 setting interface

Fig.5.10.1.1.3 other setting interface

- [DHCP]: Set whether the DHCP server automatically assigns IP to the device.
- [IPv4 Address]: Set the IP address, subnet mask and gateway of the device.
- [IPv6 Address]: This device supports IPv6. The user can select IPv6 mode as router announcement / DHCP / Manual mode in IPv6 setting. If manual mode is selected, correct IPv6 address and IPv6 subnet prefix length (value range is 3-127) need to be entered.
- [DNS]: Set the DNS server address.
- [Alternate DNS]: Set Alternate DNS server address.
- [MAC]: Display's the physical address of the device.
- [MTU]: Set the size of MTU, ranging from 500 to 1500, and the default is 1500. After setting, click Save to save the setting, and it will take effect after restarting the equipment.
- [HTTP Port]: Enter [HTTP port number] in the input box on the page, restart the device, and then modify the HTTP port number.
- [RTSP Port]: Enter [RTSP port number] in the input box on the page, restart the device, and then modify the RTSP port number.
- [HTTPS Port]: Enter [HTTPS port number] in the input box on the page, restart the device, and then modify the HTTPS port number.

- [RTSP Path]: Refer to the example path in the interface. Check enable intranet search to enable this function.
- [Save]: Save the current settings.
- [Cancel]: Restores the last saved parameter.

### Basic Set - > DDNS

Fig.5.10.1.2 DDNS setting interface

After checking [Enabled] DDNS, modify equipment [Server Domain], set [DDNS Domain], [User Name], [Password ]and [Password Confirm ], and then click [Save ] to set DDNS network server information. Click [Cancel] to restore the last saved parameter.

### Basic Set- > UPnP

Port Type	External Port	External IP Address	Internal Port	State
HTTP	29444	180.212.181.243	80	Activated
RTSP	43551	180.212.181.243	554	Activated
Data Port	30554	180.212.181.243	3000	Activated
HTTPS	49785	180.212.181.243	443	Activated
RTMP	31327	180.212.181.243	1935	Activated

Fig.5.10.1.3 UPnP interface

---

Only when port mapping is enabled, can the ports of network devices be opened normally. Port mapping methods include automatic and manual.

- When "Auto" mode is selected and UPnP is enabled, users do not need to do port mapping on the router, only need to turn on the UPnP function on the router.
- Select "Manual", the user needs to manually map the port on the router. In manual mode, the user can specify the external port to be mapped under the public IP. The user does not need to modify the port of the network device itself. If the router or gateway does not support the UPnP function, the user can fill in the current mapped external port status here.
- After the port mapping, the Status column will show whether it is effective. At the same time, the external port under the currently mapped public IP will be displayed in the external port. If users need to access network devices through the public network, they need to use the currently mapped external port to access.

[Save]: Save the current settings.

[Cancel]: Restores the last saved parameter.

## **5.10.2 Advanced Set**

### **Advanced Set - >IP Filter**

The screenshot shows the IP Filter setting interface. At the top, there are three radio buttons: "No Limit", "Whitelist" (which is selected), and "Blacklist". Below these buttons is an input field for entering an IP address, followed by "Add" and "Delete" buttons. A table with three columns is displayed below the input field. The first column contains checkboxes, the second column contains numbers (1 and 2), and the third column contains IP addresses (192.168.15.189 and 192.168.15.216). At the bottom of the interface are "Save" and "Cancel" buttons.

<input type="checkbox"/>	No.	IP
<input type="checkbox"/>	1	192.168.15.189
<input type="checkbox"/>	2	192.168.15.216

Fig.6.3.2.1 IP Filter setting interface

IP firewall, also known as black-and-white list, is provided for users to manage access rights more flexibly.

- [Disable]: Select the [Disable] button to remove the restriction of the black and white list. All IP addresses can be accessed, not only the IP addresses in the list.
- [Whitelist]: If you want to allow only a few trusted IPS to access the device, you can select the [Whitelist] button, enter the trusted IP addresses one by one, click [Add] to add to the list, and then click [Save] to make the whitelist effective. At this time, only a number of IPS specified in the list can successfully log in to the device, and login requests from other IPS will be rejected, regardless of whether their user name and password are correct or not. Users can specify up to 16 trusted IP addresses in the white list.

**Note:** When adding the white list, please confirm whether to add the IP address of the current user.

- [Blacklist]: If you want to block some IP addresses and prohibit them from accessing the equipment, you can select the button of [ blacklist], input the IP addresses you want to block one by one, click [Add]to add them to the

---

list, and then click [Save] to make the blacklist effective. At this time, the login request from any IP in the list will be rejected, regardless of whether its user name and password are correct or not.

**Note:** when adding the blacklist, please confirm whether the IP address of the current user is added.

- [Delete]: If you need to delete some IPs from the list, just select the check box on the left of these IPs and click [Delete]. Note that all IPS cannot be deleted when deleting the white list, otherwise the device will not be able to log in successfully.

**Note:** IP filtering can only be judged when a user is newly logged in, and cannot filter the logged in IP. It is strongly recommended to restart the device in time after each blacklist configuration to shield the illegal IP address.

- [Save]: Save the current settings.
- [Cancel]: Restores the last saved parameter.

### Advanced Set - > Email

The screenshot displays the 'Advanced Set - > Email' configuration interface. At the top, there is a checkbox labeled 'Enabled' which is checked. Below this, several configuration fields are listed:

- Email Server:** smtp.163.com
- Port:** 25
- Email Account:** yzj18931267882@163.com
- Email Password:** Masked with 12 dots
- Email Mode:** login (dropdown menu)
- Encryption:** None (dropdown menu)
- Email Subject:** Alarm at Floor2
- Main Email Address:** yzj18931267882@163.com
- Email Address 1:** (empty field)
- Email Address 2:** (empty field)
- Email Address 3:** (empty field)

At the bottom of the form, there are three buttons: 'Save', 'Test', and 'Cancel'.

Fig.5.10.2.2 Mail setting interface



---

After the user enables mail, the alarm server will automatically send alarm mail to the mailbox address set by the user when an alarm occurs.

- The email server address input format is smtp.xx.com, where XX represents the email server and is the login email of the account, for example, smtp.163.com.
- The account and password are the user name and password of the login SMTP server mailbox.
- Select the Email Mode.
- The encryption mode can be none, SSL or TLS.

After setting the subject and CC email address, click [Test] to test whether the mail server function is normal. Click [Save] to save the current settings. Click [Cancel] to restore the last saved parameter.

#### **Advanced Set - > PPPoE**

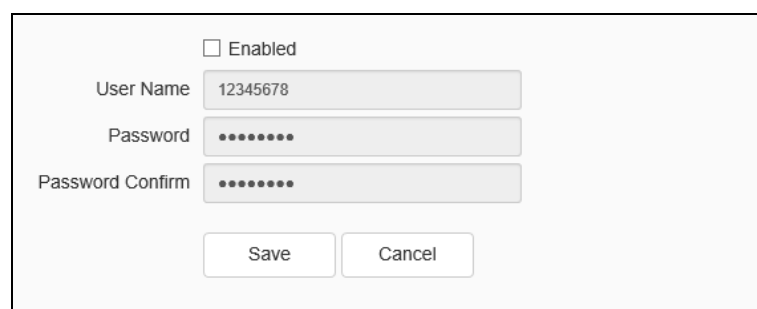

The screenshot displays the PPPoE configuration interface. At the top, there is a checkbox labeled 'Enabled' which is currently unchecked. Below this, there are three input fields: 'User Name' with the value '12345678', 'Password' with seven dots, and 'Password Confirm' with seven dots. At the bottom of the form, there are two buttons: 'Save' and 'Cancel'.

Fig.5.10.2.3 PPPoE setting interface

After enabling the [PPPoE] function, change the [User Name], [ Password ] and [Password Confirm], and [Save] to set the PPPoE network server information, which will take effect after restart;[Cancel] to restore the last saved parameters.

---

## Advanced Set - > Multicast

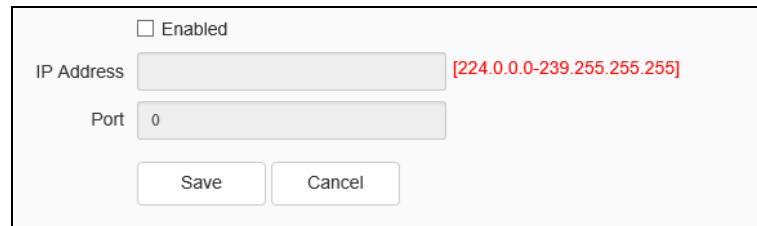

Enabled

IP Address  [224.0.0.0-239.255.255.255]

Port

Fig.5.10.2.5 Multicast setting interface

Input the multicast [IP Address] (range: 224.0.0.0-239.255.255.255), input the Port number (range: 1-65535), and click Save to restart the device.

## Advanced Set - > QoS settings

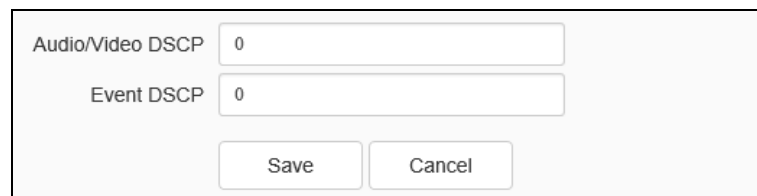

Audio/Video DSCP

Event DSCP

Fig.5.10.2.6 QoS setting interface

[Audio/Video DSCP] input the DSCP parameters in the input box, disconnect and reconnect the video stream parameters to take effect, and [Event DSCP] input the DSCP parameters in the input box, and click [Save] to save the parameters.

---

## Advanced Set - > 802.1x

Enable IEEE 802.1x

Protocol Type: EAP-MD5

EAPo1 version: 802.1x-2001

User Name:

Password:

Password Confirm:

State: Disconnected

Save Cancel Manual c...

Allow users to choose [EAPo1 version] "802.1x-2001" or "802.1x-2004", set [user name], [password], [password confirmation]. [Current Status] displays the current connection status, click [Save] to save the parameters, [Cancel] to discard the changes. After the parameters are saved, the device can automatically connect; Click [Manual Connection] to initiate an authentication connection immediately.

## Advanced Set - > Access Platform

Platform Enabled

Onvif  Allowed H265 video access

P2P

RTSP

Fig.5.10.2.7 Platform access setting interface

[Platform Enabled]

- Click to enable the desired check box - Onvif, RTSP, P2P and CGI.

**Note:** To replace the access platform, you need to first disable the enabled platform, and then select a new platform and enable it.

- 
- [Save]: Save the current settings.
  - [Cancel]: Restores the last saved parameter.

### Advanced Set - > Register Center

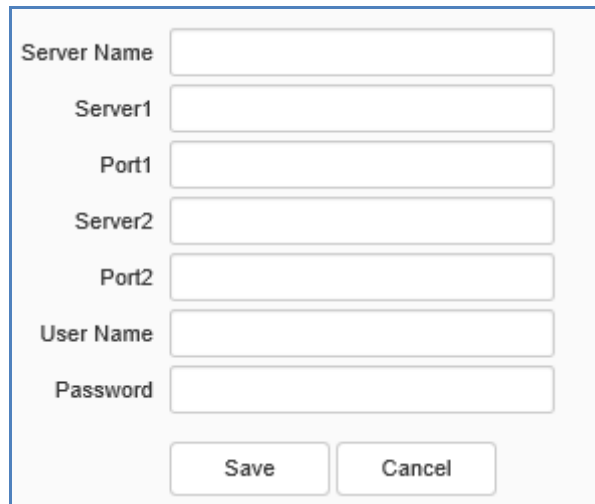

- Set [Server Name], [Server], [Port], [User Name], [Password] in [Registration Center].
- Click [Save] to save the current settings.
- Click [Cancel], to restore the parameters saved last time.

### Advanced Set - > Authentication Type

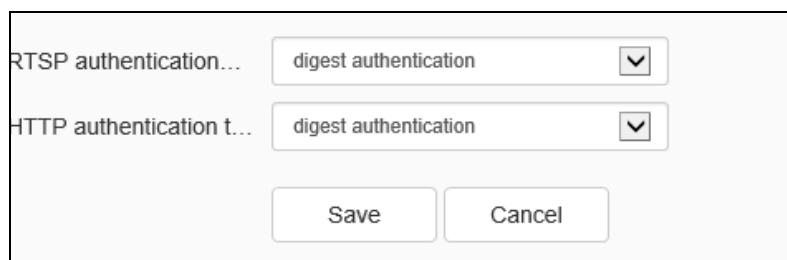

Fig.5.10.2.8 authentication type interface

Set authentication type on RTSP and HTTP as needed.

- [RTSP authentication type]: Digest and Digest & Basic authentication types are supported.

- 
- [HTTP authentication type]: Digest and Digest & Basic authentication types are supported.
  - [Save]: Save the current settings.
  - [Cancel]: Restores the last saved parameter.

### Advanced Set - >HTTPS

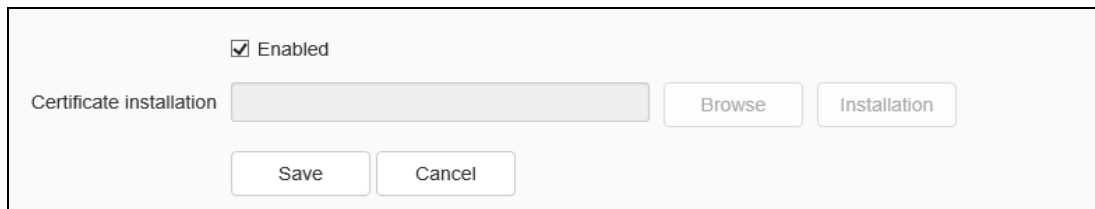

The screenshot shows a user interface for configuring HTTPS. At the top, there is a checkbox labeled 'Enabled' which is checked. Below this, the text 'Certificate installation' is followed by a text input field. To the right of the input field are two buttons: 'Browse' and 'Installation'. At the bottom of the interface are two buttons: 'Save' and 'Cancel'.

Fig.5.10.2.10 HTTPS Interface

- Import and install HTTPS certificates as needed.
- [Browse]: Browse the file directory and import the HTTPS certificate.
- [Installation]: Install the HTTPS certificate.
- [Save]: Save the current settings.
- [Cancel]: Restores the last saved parameter.

## 5.11 Event Schedule

### 5.11.1 Event Management

#### Event management - > Event Input

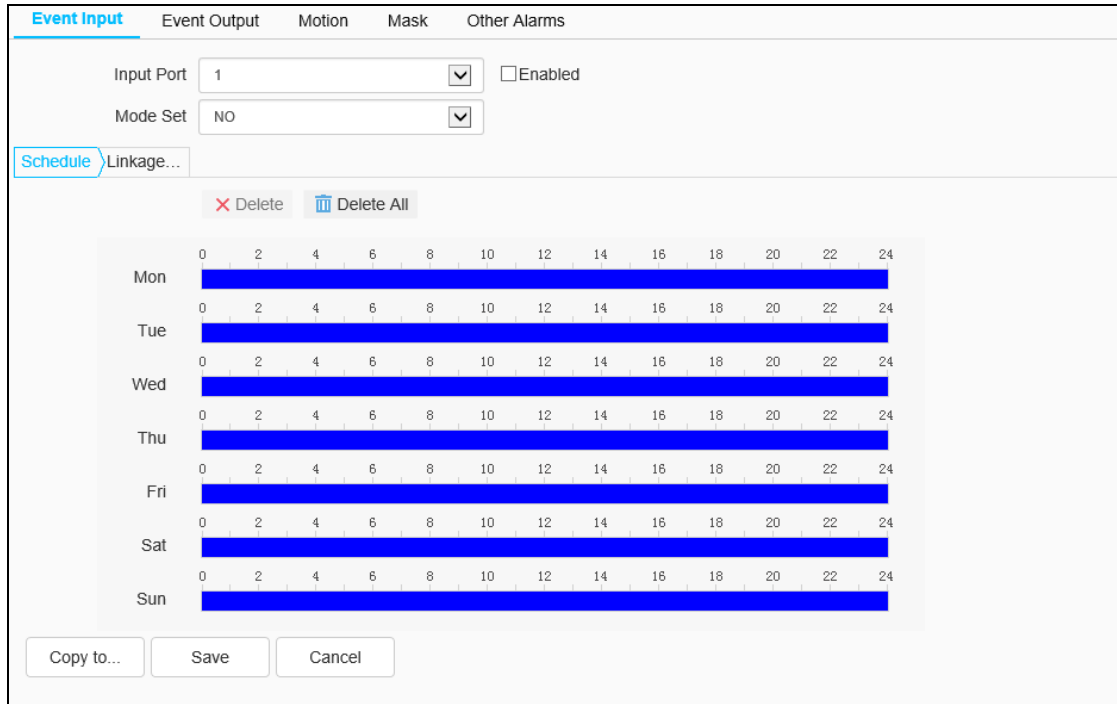

Fig.5.11.1.1.1 Event input setting interface

Set port event detection related parameters.

- Select the input port, check the [Enable] check box to enable the port alarm detection function, and uncheck to turn off the port alarm detection function. Select the desired port from the list.
- [Mode Set]: Set normally open and normally closed, where [NO] refers to the alarm when the disconnected line is short circuited, and [NC] refers to the alarm when the connected line is disconnected.
- The user can set the [Schedule] as required, and only detect the alarm within the set date and time period.
- Set [Linkage Mode] to realize the alarm linkage after triggering the alarm, such as [Alarm Output], [Link Snap],[ I PTZ linkage channel], etc. As shown in the figure below.

The screenshot shows the 'Linkage Mode Setting Interface' with the following details:

- Event Input:** Input Port: 1, Mode Set: NO, Enabled:
- Linkage Settings Table:**

Alarm Output	Link Rec	Link Snap	PTZ Linkage...
<input type="checkbox"/> 1	<input type="checkbox"/> [1] Channel 1	<input type="checkbox"/> [1] Channel 1	<input type="checkbox"/> Preset
<input type="checkbox"/> 2		<input type="checkbox"/> FTP	1
		<input type="checkbox"/> Email	<input type="checkbox"/> Mode
			1
			<input type="checkbox"/> Cruise Path
			1
- Buttons:** Copy to..., Save, Cancel

Fig.5.11.1.1.2 Linkage Mode Setting Interface

- Click [Save] to save the corresponding parameter settings, and click [Copy to...] copy the parameters of the current port number to other port numbers. Click [Cancel] to restore the last saved parameter.

**Event Management - > Event Output**

The screenshot shows the 'Event Output' setting interface with the following details:

- Output Port:** 1
- Mode Set:** NC
- Delay Time(s):** 10
- Buttons:** Save, Cancel

Fig.5.11.1.2 Event output setting interface

- Select the output port and then set the Mode. The user can select two modes to set: [NO] and [ NC]. You can set the delay time of the alarm

state through [Delay Time(s)].

- Click [Save] to save the corresponding parameter settings.
- Click [Cancel] to restore the last saved parameter.

## Event Management - > Motion

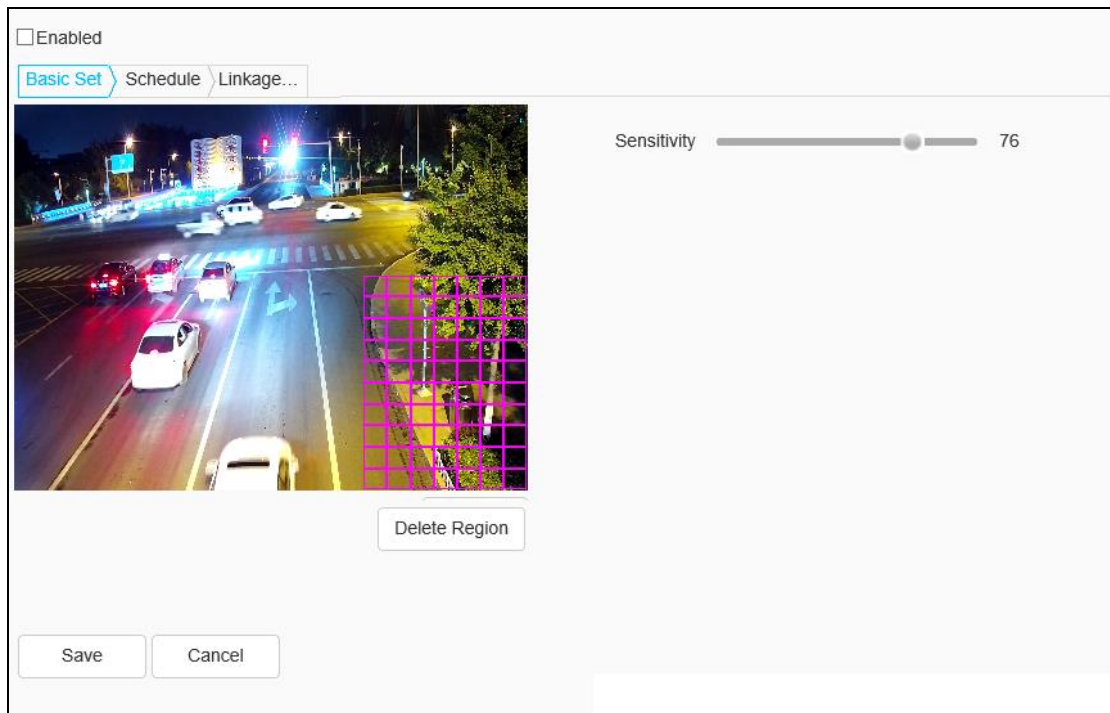

Fig.5.11.1.3 Motion setting interface

The user sets the mobile alarm area. When there is an object moving in the setting area, the video preview interface will prompt the video mobile alarm, and the corresponding alarm linkage will be carried out according to the setting.

- The mobile alarm detection function is enabled by default. Drag the left mouse button in the video screen to draw the area to detect the mobile alarm. Click [Delete Region] to delete the mobile alarm detection area.
- Set the mobile alarm sensitivity, the higher the value, the more sensitive the mobile alarm detection.
- The user can set the [Schedule] as required, and only detect the alarm



within the set date and time period.

- Set [Linkage Mode] to realize the alarm linkage after triggering the alarm, such as [Alarm Output], [Linkage Snap], etc.
- Click [Save] to save the corresponding parameter settings.
- Click [Cancel] to restore the last saved parameter.

### Event Management - > Mask



Fig.5.11.1.4 Mask setting interface

After the occlusion alarm is turned on, when the image in the video screen is blocked, the alarm situation will be detected according to the sensitivity.

- Check the [Enable] check box to turn on the video blocking alarm detection function, and uncheck to turn off the video blocking alarm detection function.
- Set the video occlusion alarm sensitivity, the higher the value, the more sensitive the video occlusion alarm detection.
- The user can set the [Schedule] as required, and only detect the alarm

---

within the set date and time period.

- Set the [Linkage Mode] to realize the alarm linkage after triggering the alarm, such as [Alarm Output], [Link Snap], etc.
- Click [Save] to save the corresponding parameter settings.
- Click [Cancel] to restore the last saved parameter.

### Event Management - > Other Alarms

<input checked="" type="checkbox"/> Event	Send To Server	Send Email	Alarm Output
<b>Storage Error</b>			
<input checked="" type="checkbox"/> Disk Full	<input checked="" type="checkbox"/>	<input checked="" type="checkbox"/>	Not Select...
<input checked="" type="checkbox"/> Disk R/W Error	<input checked="" type="checkbox"/>	<input checked="" type="checkbox"/>	Not Select...
<b>Abnormal network</b>			
<input checked="" type="checkbox"/> IP Address Conflict			Not Select...
<input checked="" type="checkbox"/> MAC address co...			Not Select...
<input checked="" type="checkbox"/> FTP server exce...	<input checked="" type="checkbox"/>	<input checked="" type="checkbox"/>	Not Select...

Save Cancel

Fig.5.11.1.5 other alarms

- You can set the Storage Errors as [Disk Full] and [Disk R/W Error] for events [Send To Server ], [Send Email] as well as [Alarm Output] the alarm output port number can be selected.
- You can set the Abnormal Network errors [FTP server exception]. ] for events [Send To Server], [Send Email] as well as [Alarm Output] the alarm output port number can be selected.
- For [IP Address Conflict] and [FTP server exception], you can only set the [Alarm Output] that is the alarm output port number can be selected.

## 5.12 Smart surveillance (VCA)

### 5.12.1 Create Rule

#### Create Rule ->Event Set

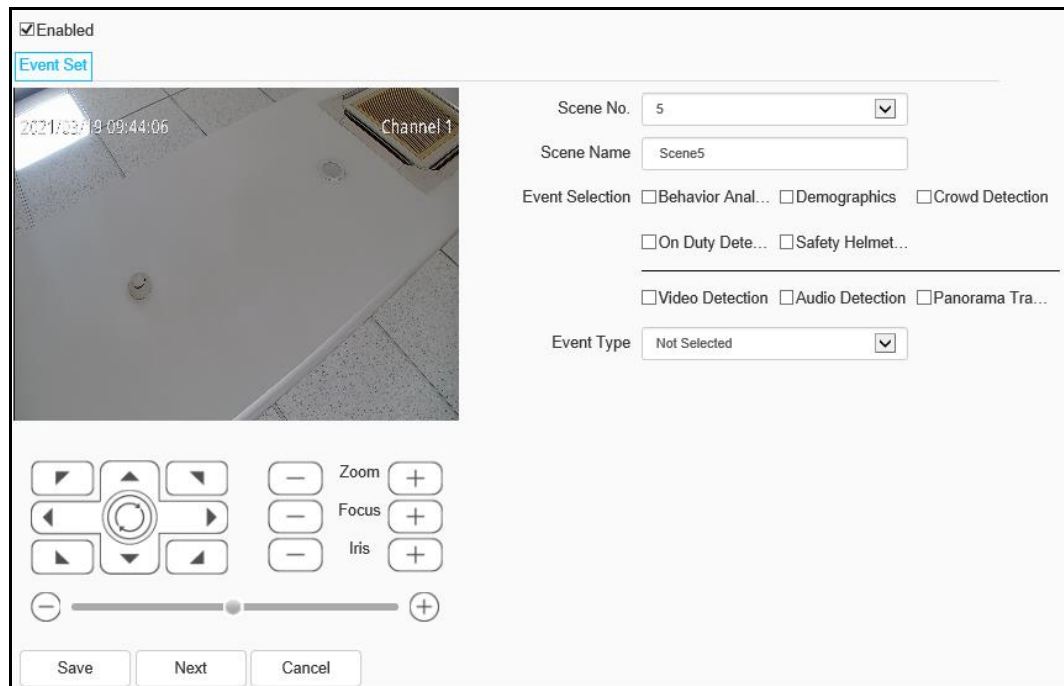

Fig.5.12.1.1 Event Set interface

- [Enabled]: Enables or disables the intelligent analysis function of the current channel. When the AEW speed dome starts the intelligent analysis, the speed dome will scan the surrounding to revise the orientation automatically to promote the tracking accuracy.
- [Scene number]: The scene number stands for different scene, can set total 16 scenes, the number range is from 1 to 16. Different scenes can be set through the dome camera control menu at the left bottom.
- [Scene Name]: The name of the scene can be defined by users themselves.
- [Event Selection]: The device supports a variety of algorithms, such as behavior analysis, crowd aggregation, face detection, number of people statistics, and on duty detection, which are mutually exclusive. Only one of them can be enabled.

- [Event Type]: Displays the option you select in Event Selection.

## Arithmetic - Behavior Analysis

**[Behavior Analysis]:** The algorithm includes tripwires, double tripwires, perimeter, items left over, items lost, wandering, running, heat map.

### Arithmetic - Behavior Analysis - Tripwire

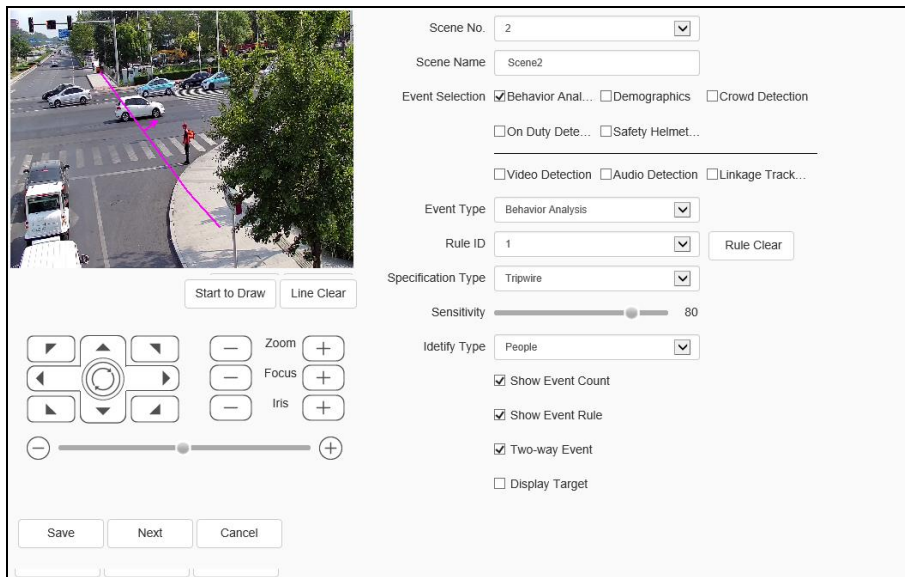

Fig.5.12.1.2 tripwire setting interface

- Select [Rule ID] that is the rule number and select [Specification Type] as Tripwire.
- Draw rule line, the arrow of line means direction of prohibit crossing.
- [Sensitivity]: Drag the slider to set the desired level.
- [Identify Type]: You can select from the options People, Cars, People and Cars, All.
- Select the check boxes of the desired options to be displayed -- alarm event count, alarm rules number, whether it is a two-way alarm and whether to display the target.
- Click [Save] to save all the settings or click [Cancel] to restore the last saved parameter.

**Note:** When the alarm target track crosses the trip wire, it will raise the alarm.

## Arithmetic - Behavior Analysis - Double Tripwire

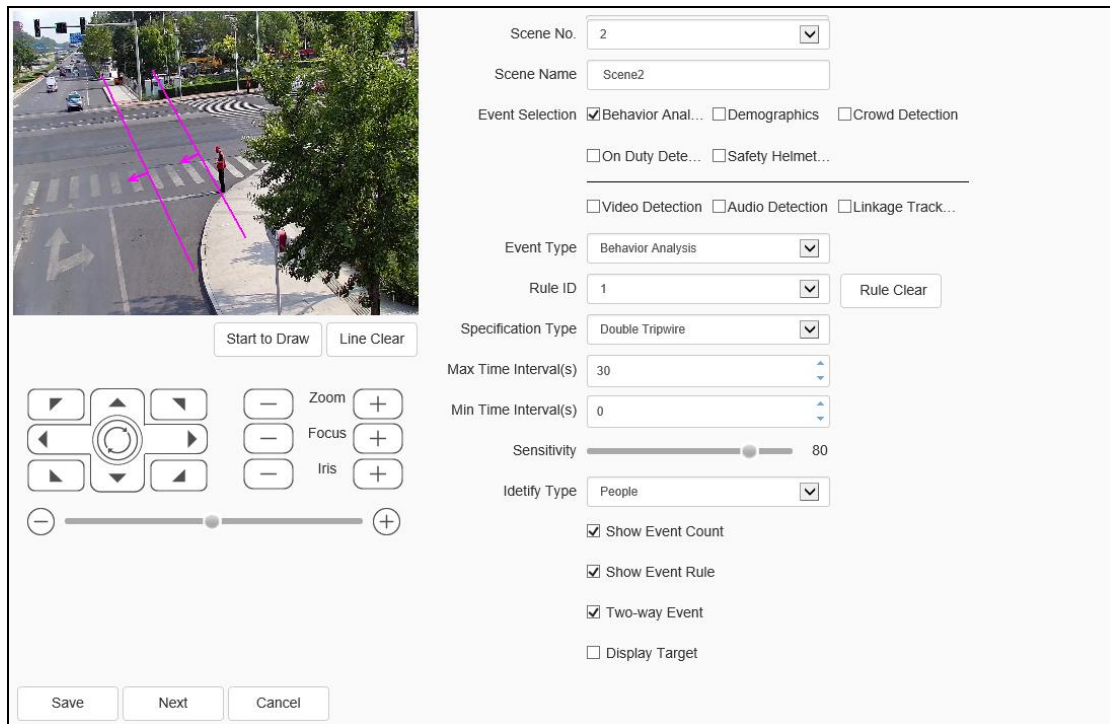

Fig.5.12.1.3 double tripwire setting interface

- Select [Rule ID] that is the rule number and select [Specification Type] as Double Tripwire.
- Draw two rule lines, the arrow of line means direction of prohibit crossing, 2 lines direction should be the same, it will alarm when target object cross 2 lines continuously within the specified time.
- Set [Max Time Interval] and [Min Time Interval]. This is the time range set to cross 2 lines continuously.
- [Sensitivity]: Drag the slider to set the desired level.
- [Identify Type]: You can select from the options People, Cars, People and Cars, All.
- Select the check boxes of the desired options to be displayed -- alarm event count, alarm rules number, whether it is a two-way alarm and whether to display the target.
- Click [Save] to save all the settings or click [Cancel] to restore the last saved parameter.

**Note:** The alarm will occur when trip wire 1 and trip wire 2 are triggered continuously within the minimum and maximum time interval of line crossing.

## Arithmetic - Behavior Analysis - Perimeter

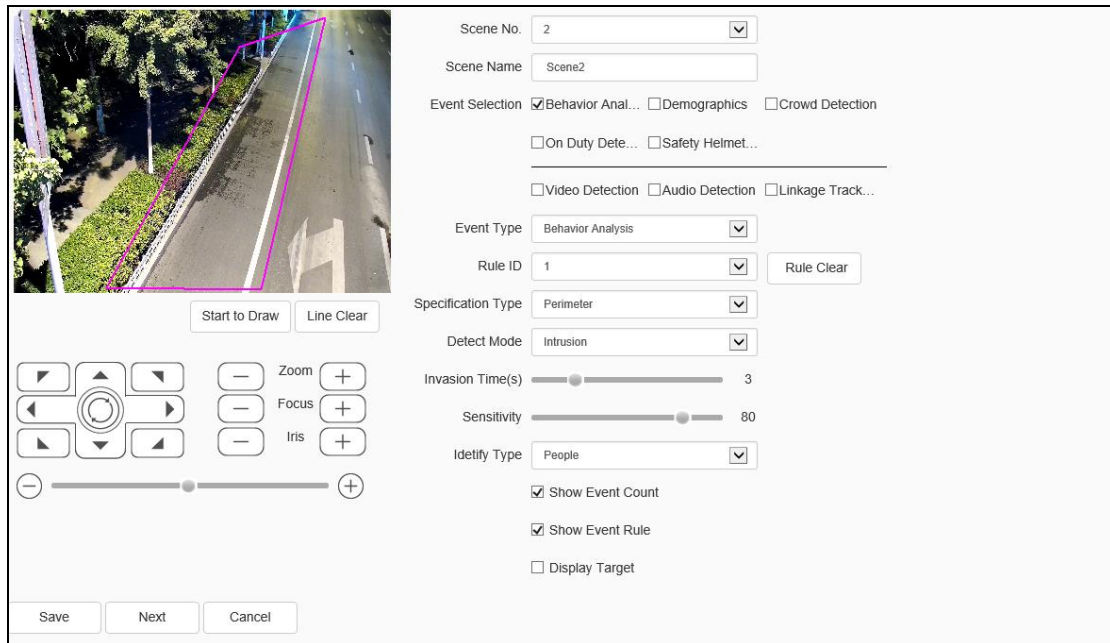

Fig.5.12.1.4 perimeter setting interface

- Select [Rule ID] that is the rule number and select [Specification Type] as Perimeter.
- Draw the detection area.
- Select [Detection Mode]. Option are [Enter] it will trigger alarm when object go in detection area; [Leave] it will trigger alarm when object go out detection area; [Intrusion] it will trigger alarm when object stay in detection area until reach [Invasion Time].
- Select the desired [Mode of intrusion] option – Alarm from departure from video area or Alarm from departure from test area.
- [Invasion Time]: Setup invasion time of object stay in detection area, it will trigger alarm when over the time.
- [Sensitivity]: Drag the slider to set the desired level.
- [Identify Type]: You can select from the options People, Cars, People and Cars, All. It is recommended to be human by default.

- Select the check boxes of the desired options to be displayed -- alarm event count, alarm rules number and whether to display the target.
- Click [Save] to save all the settings or click [Cancel] to restore the last saved parameter.

### Arithmetic - Behavior Analysis - Object Abandone

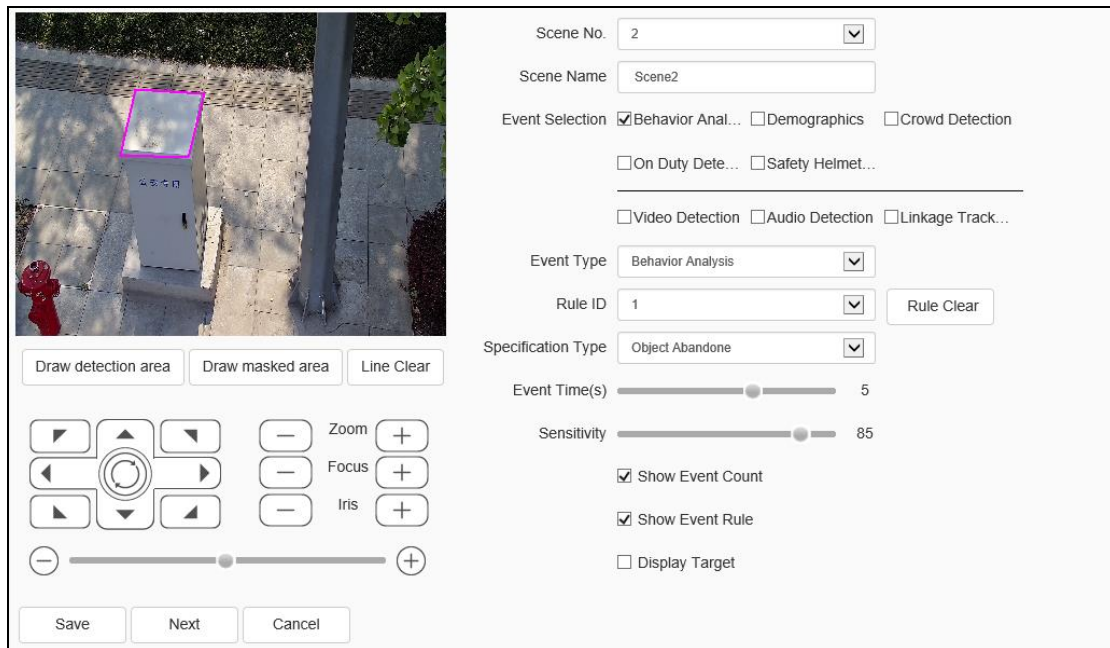

Fig.5.12.1.5 Object Abandonee setting interface

- Select [Rule ID] that is the rule number and select [Specification Type] as Object Abandone.
- Draw detection area, please notice the detection area shouldn't overlap when [Items Abandon] and [Missing Object Detection] are enable at same time.
- Set the [Event Time], that is the alarm time for which the object stays in detection area, it will trigger alarm when time exceeds the set time.
- [Sensitivity]: Drag the slider to set the desired level.
- Select the check boxes of the desired options to be displayed -- alarm event count, alarm rules number and whether to display the target.
- Click [Save] to save all the settings or click [Cancel] to restore the last saved parameter.

**Note:** The alarm will occur after the still target appears in the area and reaches the set event time.

### Arithmetic - Behavior Analysis - Missing Object Detection

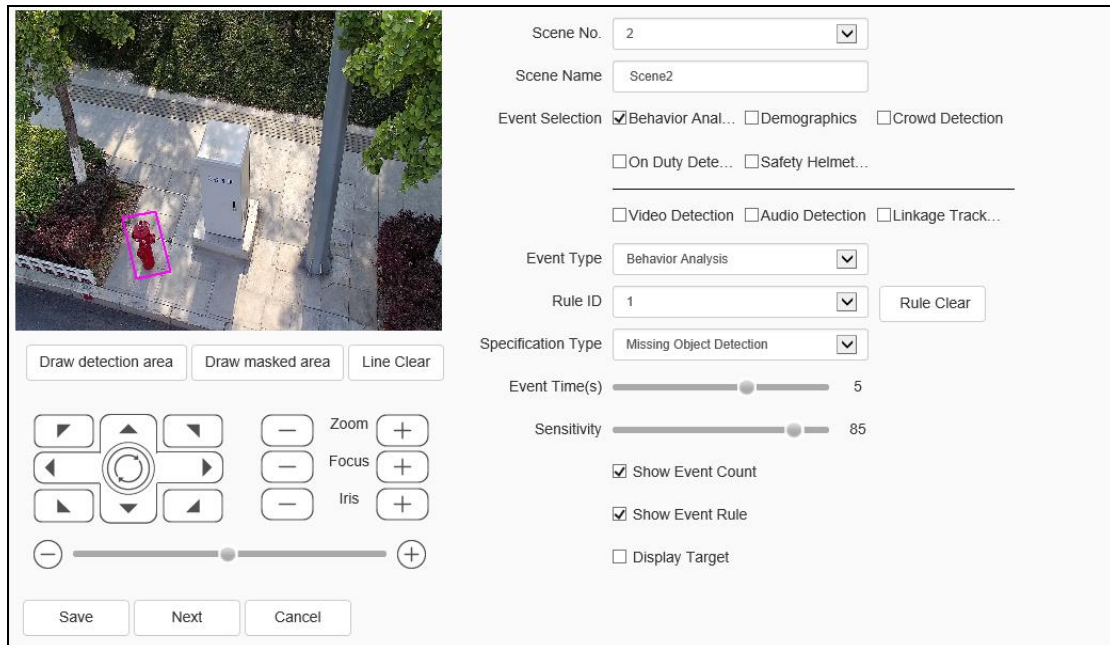

Fig.5.12.1.6 Missing Object Detection setting interface

- Select [Rule ID] that is the rule number and select [Specification Type] as Missing Object Detection.
- Draw detection area, please notice the detection area shouldn't overlap when [Items Abandon] and [Missing Object Detection] are enable at same time.
- Set the [Event Time], that is the alarm time for which the object stays in detection area, it will trigger alarm when time exceeds the set time.
- [Sensitivity]: Drag the slider to set the desired level.
- Select the check boxes of the desired options to be displayed -- alarm event count, alarm rules number and whether to display the target.
- Click [Save] to save all the settings or click [Cancel] to restore the last saved parameter.

**Note:** The alarm will occur when the target disappearing time in the area reaches the set alarm time.



## Arithmetic - Behavior Analysis - Loiter

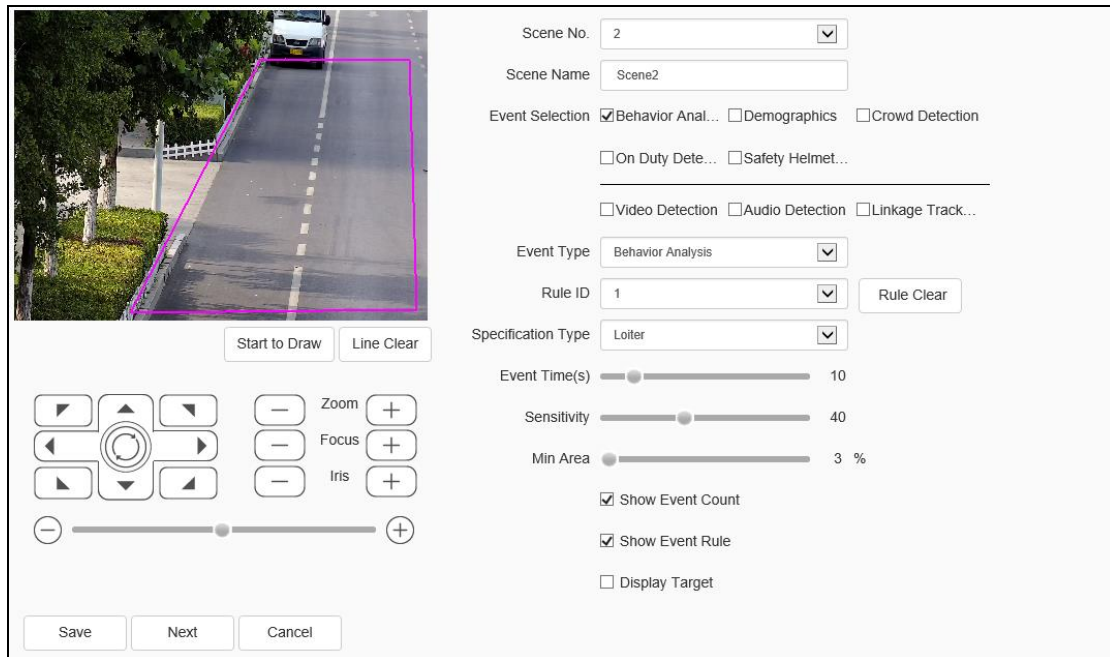

Fig.5.12.1.7 Loiter setting interface

- Select [Rule ID] that is the rule number and select [Specification Type] as Loiter.
- Draw detection area on the image.
- Set the [Event Time], that is the alarm time for which the object stays in detection area, it will trigger alarm when time exceeds the set time.
- [Sensitivity]: Drag the slider to set the desired level. Higher the value the more the sensitivity.
- Setup [Min Area]. The alarm will trigger when the object's loitering area is equal to or greater than this min area.
- Select the check boxes of the desired options to be displayed -- alarm event count, alarm rules number and whether to display the target.
- Click [Save] to save all the settings or click [Cancel] to restore the last saved parameter.

**Note:** The alarm will occur when the moving target continuously reaches the set alarm time in the area or the moving range reaches the set minimum area.

## Arithmetic - Behavior Analysis – Running

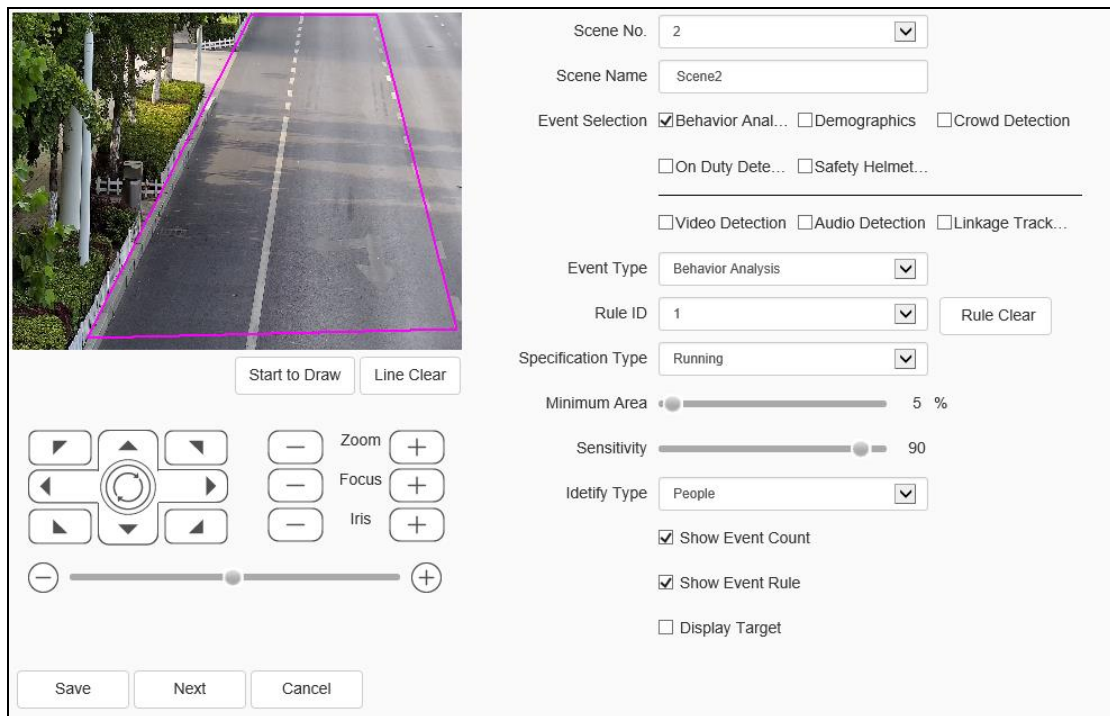

Fig.5.12.1.8 running setting interface

- Select [Rule ID] that is the rule number and select [Specification Type] as Lioter.
- Draw detection area on the image.
- Setup [Min Area]. The alarm will trigger when the object's running area is equal to or greater than this min area.
- [Sensitivity]: Drag the slider to set the desired level. Higher the value the more the sensitivity.
- Select the check boxes of the desired options to be displayed -- alarm event count, alarm rules number and whether to display the target.
- Click [Save] to save all the settings or click [Cancel] to restore the last saved parameter.

**Note:** The alarm will occur when the speed of moving target in the area is greater than the set moving distance per second

## Event Type - Behavior Analysis - Heatmap

Scene No. 2

Scene Name Scene2

Event Selection  Behavior Anal...  Demographics  Crowd Detection

On Duty Dete...  Safety Helmet...

Video Detection  Audio Detection  Linkage Track...

Event Type Behavior Analysis

Rule ID 1 Rule Clear

Specification Type Heatmap

Minimum Area 5 %

Sensitivity 95

Start to Draw All Line Clear

Zoom Focus Iris

Save Next Cancel

Fig.5.12.1.9 heat map setting interface

- Select [Rule ID] that is the rule number and select [Specification Type] as Heatmap.
- Draw detection area on the image.
- Setup Minimum Area, alarm will be triggered when the object's running area is equal to or greater than this minimum area.
- [Sensitivity]: Drag the slider to set the desired level. Higher the value the more the sensitivity.
- Click [Save] to save all the settings or click [Cancel] to restore the last saved parameter.

## Event Type - Behavior Analysis - Parking

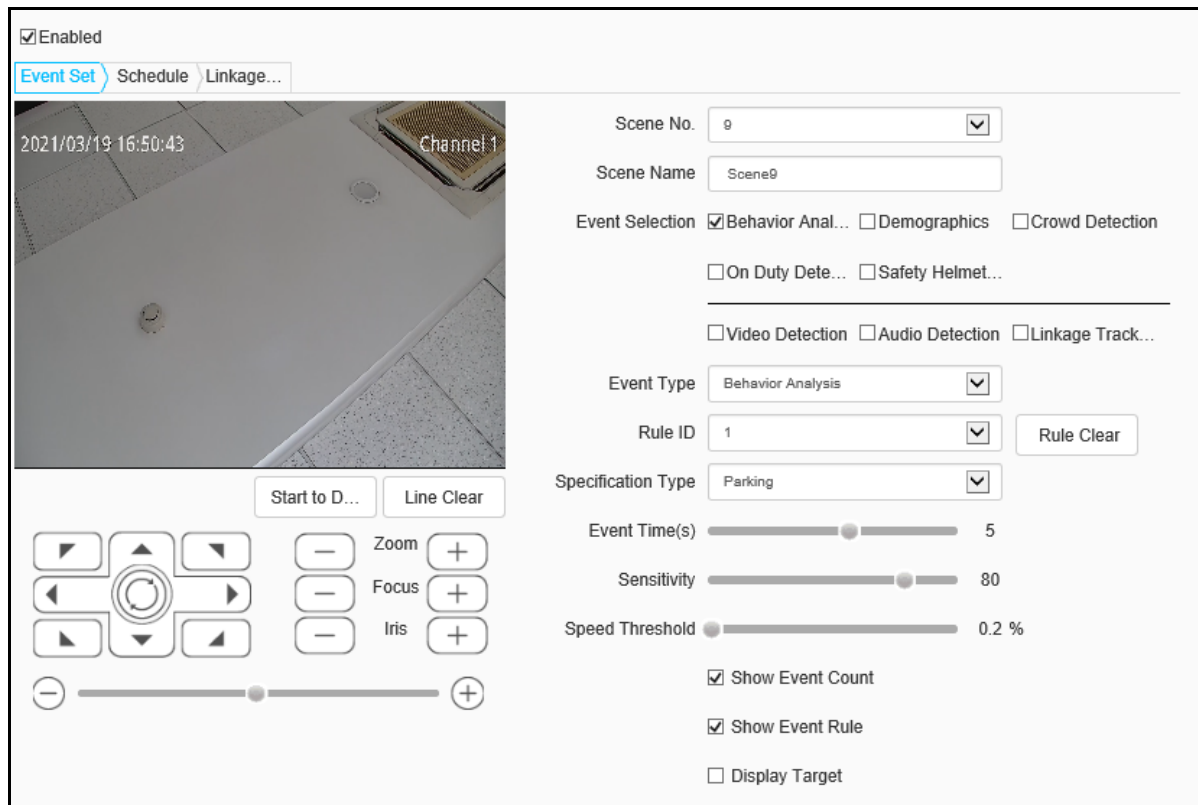

Fig.5.12.1.9 heat map setting interface

- Select [Rule ID] that is the rule number and select [Specification Type] as Parking.
- Draw detection area on the image.
- Set the [Event Time], that is the alarm time for which the object stays in detection area, it will trigger alarm when time exceeds the set time.
- [Sensitivity]: Drag the slider to set the desired level. Higher the value the more the sensitivity.
- Set the [Speed Threshold], alarm is triggered when the object's moving speed (percent/second) is slower than this speed threshold.
- Select the check boxes of the desired options to be displayed -- alarm event count, alarm rules number and whether to display the target.
- Click [Save] to save all the settings or click [Cancel] to restore the last saved parameter.

## Behavior analysis - Linkage Tracking

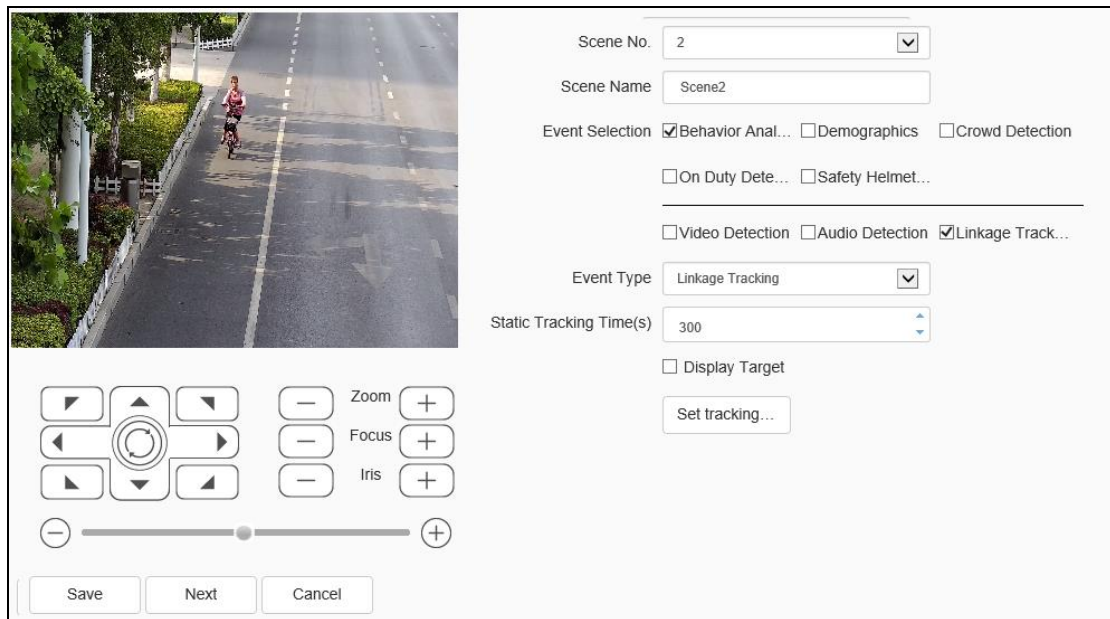

Fig.5.12.1.10.1 Linkage tracking setting interface

- Select [Screen No] and enter the [Screen Name], if required.
- Select the Behavioral Analysis check box for [Event Selection].
- Select the Linkage Tracking check box for [Event Type].
- When the target triggers the behavior analysis alarm, it will follow the tracking action.
- Select the Behavior Analysis and Intelligent Tracking in the algorithm configuration and then set the corresponding settings; the behavior analysis setting is the same as above and the intelligent tracking's setting are explained below.
- Set the [Static Tracking Time (s)]: it indicates the duration of the dome camera for tracking the target and the default time is 300 seconds. When set to 0s, the dome camera keeps tracking until the target disappears.
- Click [Set tracking], to set the needed tracking manually. Set the parameters as per your requirement. When tracking, it will track the target as per the set parameters. Click [Save].

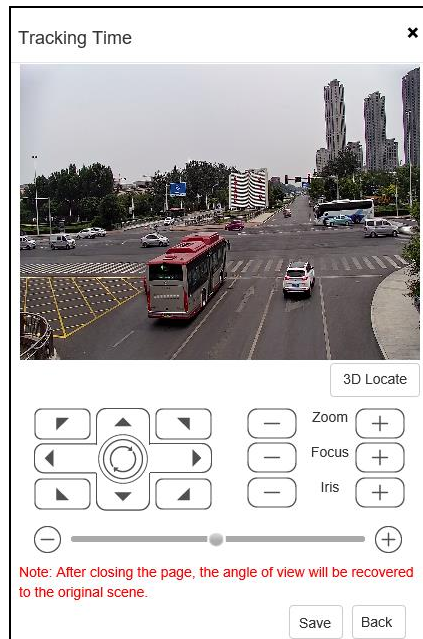

Fig.5.12.1.10.2 tracking time setting interface

- Select the Display Target check box if required.
- Click [Save] to save all the settings or click [Cancel] to restore the last saved parameter.

## Arithmetic – Demographics

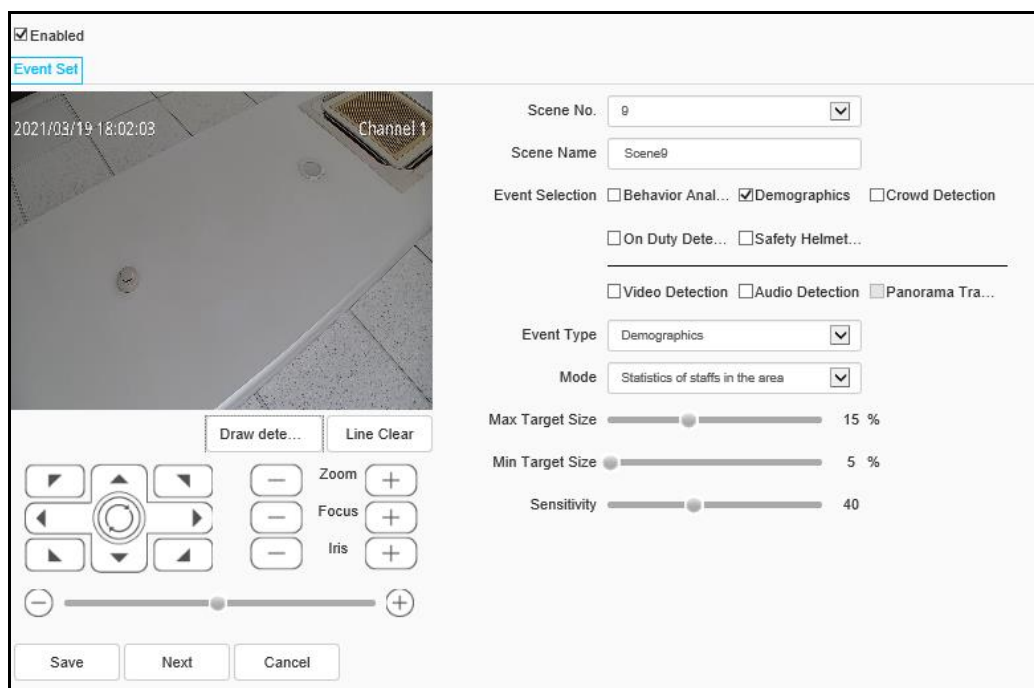

Fig.5.12.1.12 Demographic setting interface

- Select [Screen No] and enter the [Screen Name], if required.
- Select the Demographics check box as [Event Selection]. The [Mode] will be set as Statistics of staffs in the area.
- Draw detection area on the image.
- Setup [Max Target Size] and [Min Target Size], the size means target width compare to screen width.
- Drag the slider to set the desired level of [Sensitivity]. Higher the value the more the sensitivity.
- Click [Save] to save all the settings or click [Cancel] to restore the last saved parameter.

**Note:** Only vertical statistics are supported.

### Arithmetic - Crowd Detection

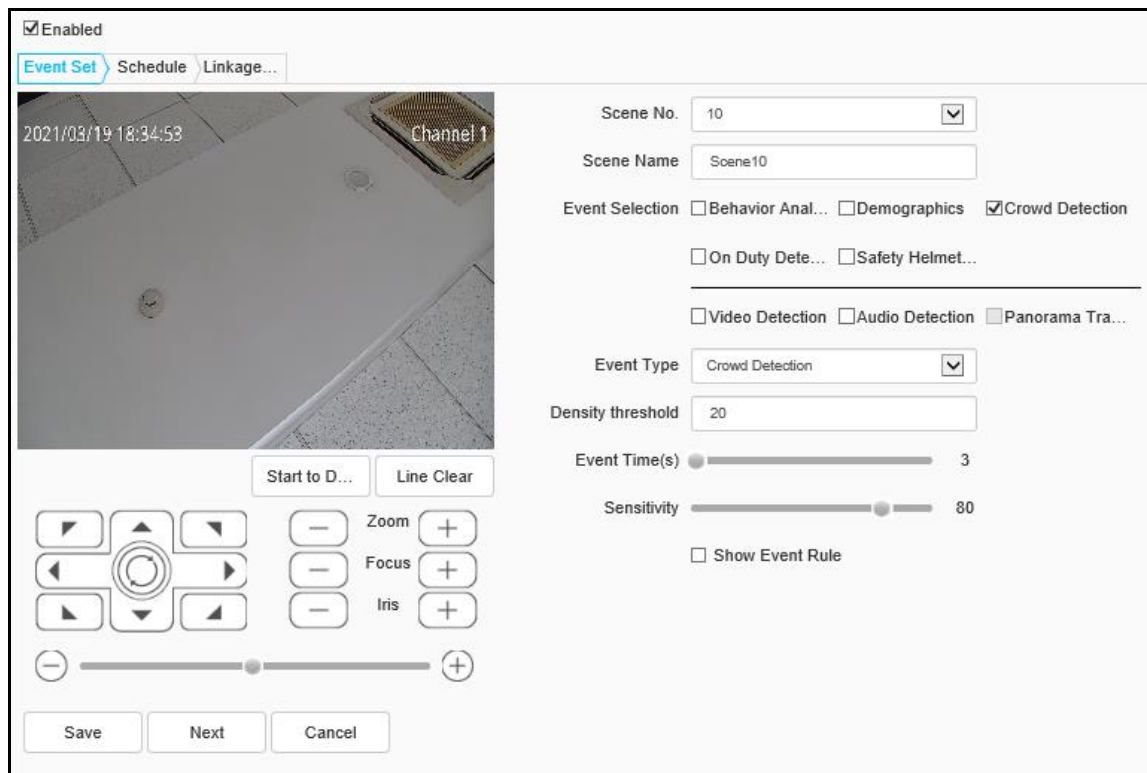

Fig.5.12.1.13 Crowded Detection Setting Interface

- Select [Screen No] and enter the [Screen Name], if required.
- Select the Crowd Detection check box for [Event Selection]. The [Mode] will be set as Statistics of staffs in the area.
- Draw the crowd gathering detection area on the image.
- Set the [Density Threshold]. The alarm will be triggered when the intensity of moving targets in the detection area exceeds the set value.
- Set the [Event Time], which indicates that the alarm will be triggered after the time exceeds.
- Set the desired level of [Sensitivity]. Sensitivity represents the proportion of moving targets in the area of detection area.
- Select the Show Event Rule check box, if required.
- Click [Save] to save all the settings or click [Cancel] to restore the last saved parameter.

### Arithmetic - On Duty Detection

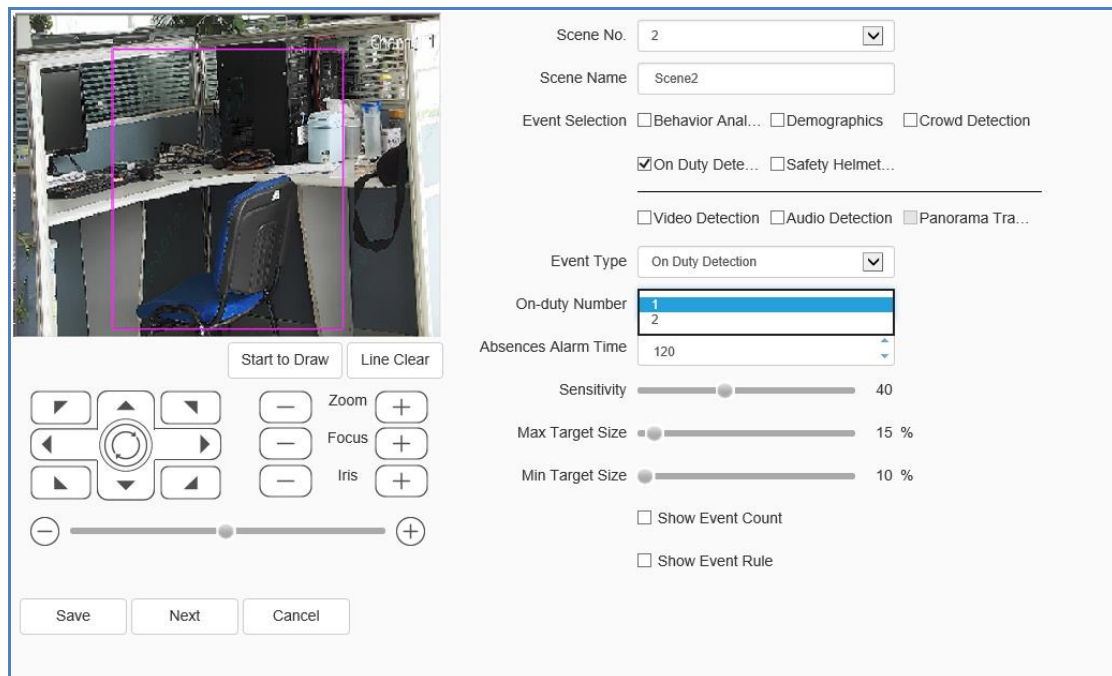

Fig.5.12.1.14 On Duty Detection Setting Interface



- Select [Screen No] and enter the [Screen Name], if required.
- Select the On Duty Detection for [Event Selection].
- Draw the duty detection area.
- Select the [On-duty Number].
- Set the Absences Alarm Time. This alarm will be raised when the person's absence time exceeds the set time.
- Set the desired level of [Sensitivity]. The higher value relates to higher sensitivity.
- Setup [Max Target Size] and [Min Target Size], the size means target width compare to screen width.
- Select the [Show Event Rule], [Show Event Count] check box, if required.
- Click [Save] to save all the settings or click [Cancel] to restore the last saved parameter.

## Arithmetic – Safety Helmet Detection

The screenshot displays the configuration interface for Safety Helmet Detection. On the left, a video feed shows a person's head with a red rectangular detection area. The video includes a timestamp '2021/09/22 14:13:16' and 'Channel 1' text. Below the video are controls for 'Draw dete...', 'Re-calibrat...', and 'Line Clear', along with directional arrows for zoom, focus, and iris, and a horizontal slider. The configuration panel on the right includes: 'Enabled' checkbox (checked), 'Event Set' tab, 'Scene No.' dropdown (1), 'Scene Name' text box (Scene1), 'Event Selection' section with checkboxes for Behavior Anal..., Demographics, Crowd Detection, On Duty Dete..., and Safety Helmet... (checked), 'Event Type' dropdown (Safety Helmet Detection), 'Monitoring Area' dropdown (Gateway), 'Sensitivity' slider (80), and checkboxes for Detect Helmet Color, Show Alarm Rule, and Display Target. At the bottom are 'Save', 'Next', and 'Cancel' buttons.

- 
- Select [Screen No] and enter the [Screen Name], if required.
  - Select the Safety Helmet Detection for [Event Selection].
  - The [Event Type] will display Safety Helmet Detection.
  - Select the [Monitoring Area] as Gateway or Construction Area.
  - Draw the monitoring area, entrance or exit or construction area according to the actual scene.
  - Click the [Start to Draw] button to draw the area, click the left mouse button to set the drawing area, and click the right mouse button to end the area line.
  - Adjust the zoom and direction, and draw the calibration frame in the middle of the screen so that the calibration frame frames the head and shoulders of the detection target. If you need to adjust the calibration from, click [Re-calibration Targets]
  - You can choose whether to detect the color of the helmet. If you need to detect, select the [Detect Helmet Color] check box and for [Event Color], select the check box of the desired color of the helmet that needs to be alarmed. When someone wears that color helmet, an alarm is triggered.
  - You can also select the [Display Target] or/and [Shown Alarm Rule] check box, if required.
  - Click Next to set the alarming time and linkage mode.

**Note:** When the illuminance is low, it will affect the recognition rate of the algorithm. Please keep the illumination of the application site well. In black and white mode, the algorithm will automatically turn off.
  - Click [Save] to save all the settings or click [Cancel] to restore the last saved parameter.

---

## Arithmetic - Video Detection

Video Detection  Audio Detection  Panorama Tra...

Event Type

Lens Dignose

Sensitivity  60

Scéen Switch Dignose

Sensitivity  60

Fig.5.12.1.17 Video Detection Setting Interface

- Select [Screen No] and enter the [Screen Name], if required.
- Select the Video Detection for [Event Selection].
- [Event Type] will display Video Detection.
- Enable the [Lens Dignose] and/or [Scéen Switch Dignose] check box.
- Set the desired level of [Sensitivity] for each. A higher value relates to higher sensitivity.
- Click [Save] to save all the settings or click [Cancel] to restore the last saved parameter.

## Arithmetic - Audio Detection

Video Detection  Audio Detection  Panorama Tra...

Event Type

Signal Loss Detection

Sensitivity  60

Signal Abnormal Detection

Sensitivity  60

Fig.5.12.1.18 Audio Detection Setting Interface

- Select [Screen No] and enter the [Screen Name], if required.

- Select the Audio Detection for [Event Selection].
- [Event Type] will display Audio Detection.
- Select the [Signal Loss Detection] and/or [Signal Abnormal Detection] check box.
- Set the [Sensitivity] the higher the value, the higher the sensitivity and the false detection will also increase.
- Click [Save] to save all the settings or click [Cancel] to restore the last saved parameter.

The next step is to link to the alarm setting interface. After setting details here, set the [Schedule] and [Linkage Mode] to intelligent analysis and alarm linkage. Click [Next] to enter the [Schedule] setting.

### Arithmetic - Panorama Tracking

The screenshot shows a configuration window for Panorama Tracking. At the top, there are three checkboxes: 'Video Detection' (unchecked), 'Audio Detection' (unchecked), and 'Panorama Tra...' (checked). Below these are three dropdown menus: 'Event Type' is set to 'Panorama Tracking', 'Static Tracking Time(s)' is set to '300', and 'Identify Type' is set to 'People'. There is also a checkbox for 'Display Target' which is unchecked. At the bottom, there is a button labeled 'Set tracking...'.

Fig.5.12.1.19 Panorama Tracking setting interface

- Select [Screen No] and enter the [Screen Name], if required.
- Select the Panorama Tracking for [Event Selection].
- [Event Type] will display Panorama Tracking.
- Set the [Static Tracking Time (second)]. It indicates the duration of the dome camera for tracking the target and the default is 300 seconds. When set to 0s, the dome camera keeps tracking until the target disappears.
- Set the [Identify Type] as Cars, People, People and Cars, All.

- Click [Set tracking], to set the needed tracking manually. Set the parameters as per your requirement. When tracking, it will track the target as per the set parameters. Click [Save].
- To display the target select the [Display Target] check box.
- Click [Save] to save all the settings or click [Cancel] to restore the last saved parameter.

### Create Rule->[Schedule]

If you have selected any one of the following as Event Selection options - Behavioral Analysis, Crowd Detection, On Duty Detection, Safety Helmet Detection, Video Detection, Audio Detection, you need to set the Schedule and Linkage Mode.



Fig.5.12.1.20 schedule setting interface

Set the effective time of the rule. By default, it is 24 hours a day. Click the blue bar to modify the deployment time.

To clear the selection for a single day, click **Delete**.

To clear the selection for all the days, click **Delete All**.

Click the Copy to...  green icon on the right to select the day of the week.

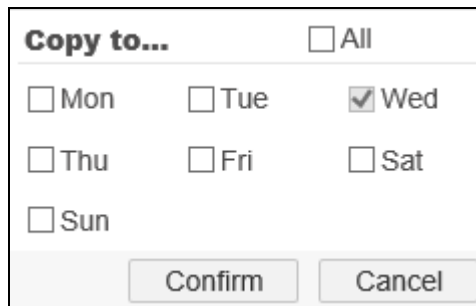
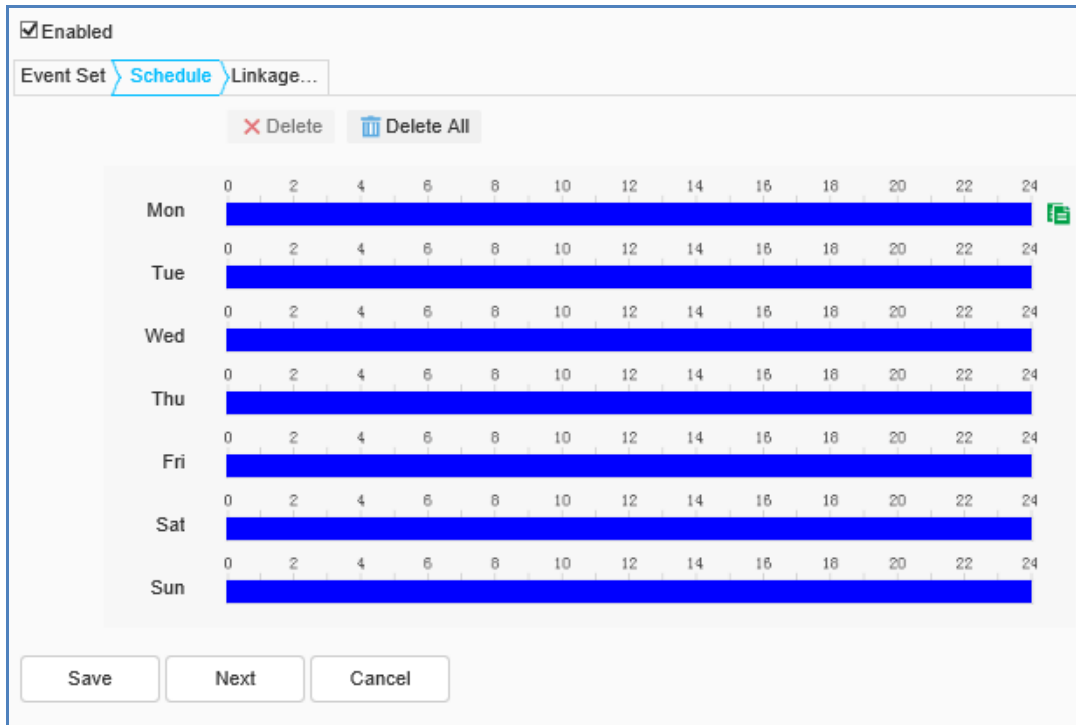

Fig.5.12.1.21 Copy to interface

Click [Save].

Click [Next] to enter [Linkage Mode] setting.

## Create Rule->[Linkage Mode]

Enabled

Event Set > Schedule > Linkage...

<input type="checkbox"/> Alarm Output	<input type="checkbox"/> Link Rec	<input type="checkbox"/> Link Snap
<input type="checkbox"/> 1	<input type="checkbox"/> [1] Channel 1	<input type="checkbox"/> [1] Channel 1
<input type="checkbox"/> 2		<input type="checkbox"/> FTP
		<input type="checkbox"/> Email

Save Next Cancel

Fig.5.12.1.22 Linkage Mode setting interface

Set the alarm linkage function when the alarm occurs. For example: [Alarm Output], [Link Rec], [Linkage Snap].

Click [Save] to save the parameter settings. Click [Cancel] to restore the last saved parameter.

## 5.12.2 Shield Area

Attention: When the original scene is changed, it needs to configure the shield area again.

Scene No. Smart Scene-1  Enabled

Save Cancel

Start to Draw Line Clear

Fig.5.12.2 Shield Area setting interface

---

Shield Area refers to reducing the false alarm rate by drawing the area in the scene and not using the target in the drawn area as the warning target. For example: lights, branches and so on.

Support the blocking area settings of intelligent analysis scene and alert scene, select the corresponding scene, click [Enabled] check box and draw the area in the screen. Click [Save] to take effect.

When scene changes, the shield area automatically fails and needs to be reconfigured.

This function can only be set in intelligent monitoring mode.

### 5.12.3 Cruise Set

<input type="checkbox"/>	No.	Scene No.	Scene Name	Start Time	Stop Time	Operation
<input type="checkbox"/>	1	13	Floor 1	00:00	23:59	Edit

Fig.5.12.3.1 Timed Cruise setting interface



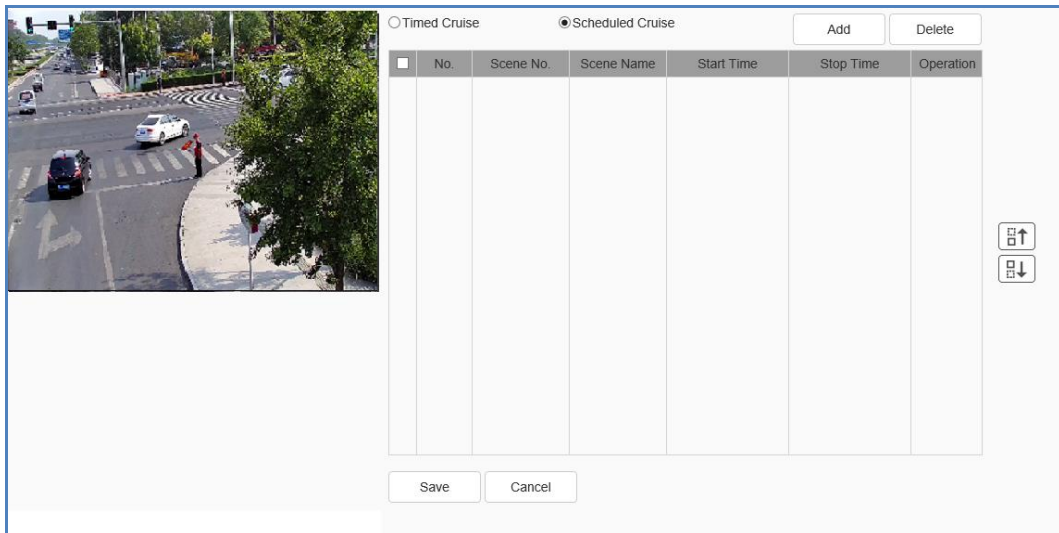



Fig.5.12.3.2 Scheduled Cruise setting interface

- The cruise mode is used to set the scene cruise of different intelligent analysis, and can be set to be timed cruise and cruise by time period (scheduled cruise). The cruise order can be adjusted through the up  and down  button on the interface.
- [Add]: It is used to add the cruise scene.
- [Delete]: After checking the appropriate scene, delete the selected cruise scene.
- [Save]: Save the set cruise parameter.

### Timed Cruise

- [Retention time (s)]: Click to set the retention time of the cruise scene.
- [Scene No.]: Click if you wish to change it.

### Scheduled Cruise

- [Start time]: Set the cruise start time of the scene.
- [End time]: Set the cruise end time of the scene.
- [Edit]: Click to change the Start or End time. Click [Confirm].
- [Scene No.]: Click if you wish to change it.

## 5.12.4 Advance Params

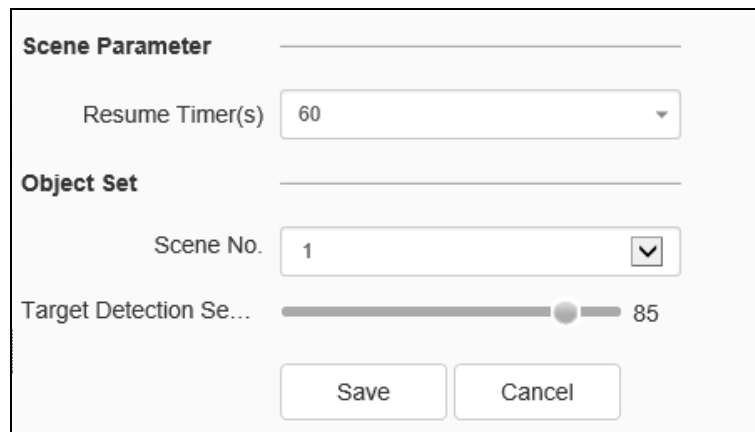

The screenshot shows a dialog box titled "Advance Params". It is divided into two main sections: "Scene Parameter" and "Object Set". Under "Scene Parameter", there is a "Resume Timer(s)" dropdown menu currently set to "60". Under "Object Set", there is a "Scene No." dropdown menu set to "1" and a "Target Detection Se..." slider control set to "85". At the bottom of the dialog, there are two buttons: "Save" and "Cancel".

Fig.5.12.4 Advance Params

[Advance Params]: is only available for company engineer to setup.

Upon the completion of the setting of the above parameters – Scene and Object, click [Save] to save and enable; Click [Cancel] to restore parameters saved last time.

## 5.12.5 VCA Report

### VCA Report->Heatmap

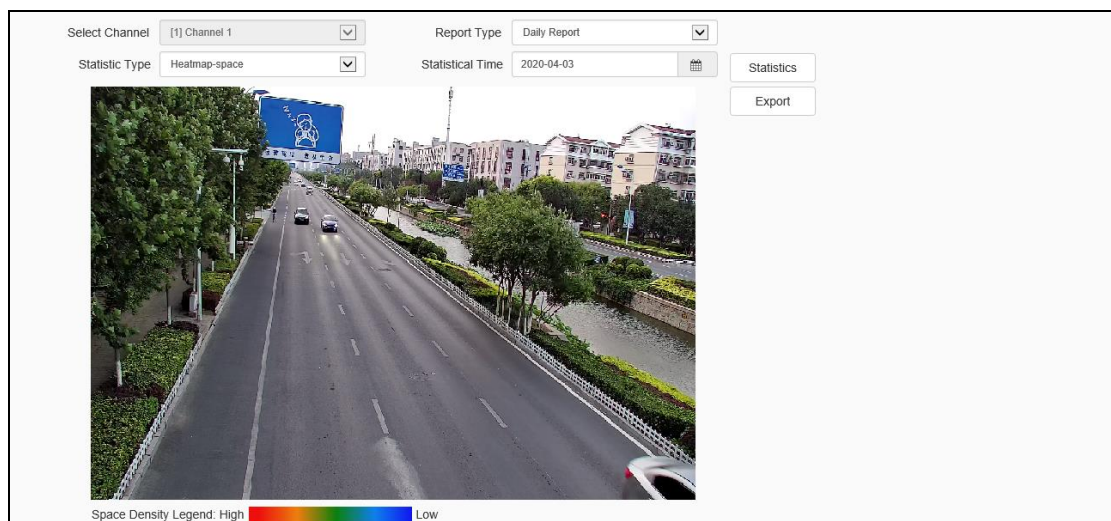

The screenshot displays the "VCA Report" interface for generating a heatmap. At the top, there are four dropdown menus: "Select Channel" (set to "[1] Channel 1"), "Report Type" (set to "Daily Report"), "Statistic Type" (set to "Heatmap-space"), and "Statistical Time" (set to "2020-04-03"). To the right of these are "Statistics" and "Export" buttons. The main area is a video feed of a road scene with a heatmap overlay. Below the video, a legend reads "Space Density Legend: High" (red) to "Low" (blue).

Fig.5.12.5.1 Heatmap setting interface

Set the Statistic Type, Report Type and Statistical Time. Click [Statistics] to display the statistics result on the screen. Click [Export] to save the statistical

---

data in the local.

### 5.12.6 Online VCA Log

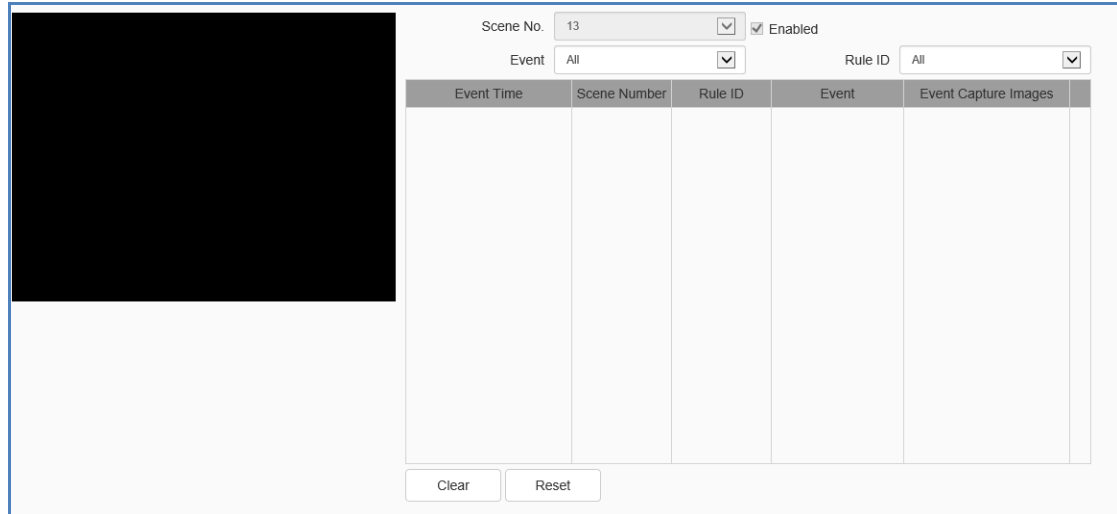

Fig.5.12.6 Online VCA Log setting interface

- [Scene No.]: check alarm information about the related scene.
- [Event]: check certain or all VCA events alarm information.
- [Rule ID]: check certain or all rule's alarm information.
- [Reset]: Reset the alarm times of the event, it will restart from 1 when alarm occurs.
- [Clear]: Clear all alarm information from current list.

**Note:** Click the path of the alarm snapshot image to preview the local image. This is a real-time function. After switching the interface, the information will be cleared and recorded again. This interface only displays the latest alarm information. If you want to view more pictures, you need to view them from the path of smart analysis snapshot.

## 5.13 Storage

### 5.13.1 Schedule Recording

#### Schedule Recording -> Schedule Recording

Recording Location  SD/USB  FTP

Record Status  ▼

Manual

Schedule

	0	2	4	6	8	10	12	14	16	18	20	22	24
Mon	[Blue bar]												
Tue	[Blue bar]												
Wed	[Blue bar]												
Thu	[Blue bar]												
Fri	[Blue bar]												
Sat	[Blue bar]												
Sun	[Blue bar]												

ANR  ▼ Note: Offline recording will follow timing recording rule.

Pre-Event Recording  ▼

Pre-Event Time (S)  ▼

Post-Event Time (S)  ▼

Fig.5.14.1.1 Schedule Recording setting interface

Switch the drop-down box to select the target video type, set the arming time, retention time (days), select the pre-recorded time, postpone the time.

[Record Status]: Show the device recording status.

[Record Beings]: Click to test beings switch to start recording and stop recording.

[Timed video recording]: It can set four time periods to perform timing video recording. Set the parameter of the conventional recording time period to the selected week.

---

[Offline Video Recording]: when the internet is disconnected, it will start timing recording into camera SD card.

Click the [Save] button to save the settings .Click the [Copy to...] button to copy the setting to other ports. Click [reset] will cause the parameters to be restored.

**Note:** Offline Video Recording is only available on cameras with SD card, when turn on this function, schedule recording will be stopped.

### Schedule Recording->Packaging Mode

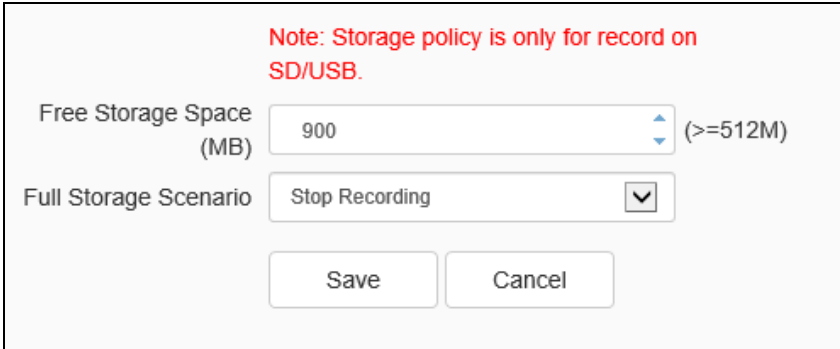

Note: Storage policy is only for record on SD/USB.

Free Storage Space (MB) 900 (>=512M)

Full Storage Scenario Stop Recording

Save Cancel

Fig.5.14.1.2 Packaging Mode setting interface

- For the [Free Disk Space] set, trigger conditions for storage can be set in the [Full Storage Scenario] edit box.
  - Stop Recording: stop the recording and packaging operation.
  - Overwrite: Delete the earliest video files to create space for the latest recording.
  - Overwrite (Exclude Event Record Videos): Delete the earliest video files (except for Alarm Rec) to create space for the newest recording. (The log file will not be deleted)
- Click [Save] button to save the corresponding parameter settings. Click [Cancel] will cause the parameters to be restored.

## 5.13.2 Picture Setting

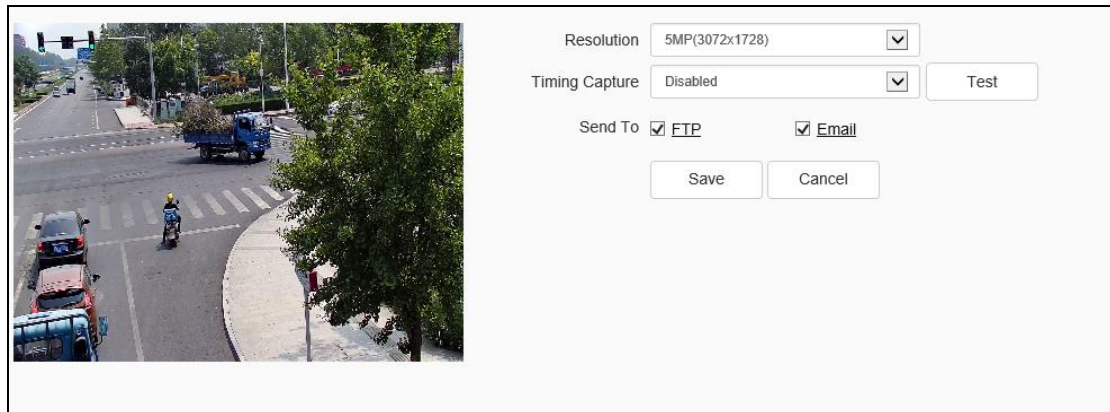

Fig.5.14.2 Picture Setting interface

- Set the desired [Resolution].
- You can Enable/Disable [Timing Capture]. Select the desired option from the drop-down list.
- [Interval]: Enter the desired time interval in the input box. You can enter the desired value and select the desired unit from the drop-down list (hourly, minutes, second).
- Choose [FTP], if you want to upload the captured photos on the FTP.
- Choose [Email], if you want the captured photos to be sent to the designated email.
- [Test]: Click Test, to check the settings done.
- Click [Save] to keep record.
- Click [Cancel] to recover data of last time.

### 5.13.3 Disk Management

<input type="checkbox"/>	Device	Total Space	Used Space	Free Space	State	Usage	Operation
<input type="checkbox"/>	SD1	27.50GB	1.00GB	26.50GB	Using	Record	

26.50GB/27.50GB(Residual Capacity/Total Capacity)

Fig.5.14.3 Disk Management

The interface can show the remaining capacity, total capacity of the current hard disk and virtual disk, as well as the disk use, with video, backup, redundancy and read-only four options

- Click [initialize Disk], to select a particular piece of disk from the list and then click the "Initialize Disk" button, the system pop-up whether you want to initialize the disk, click the "OK" after the initialization of the disk for operation.

### 5.13.4 FTP

**FTP - > FTP Network Storage**

---

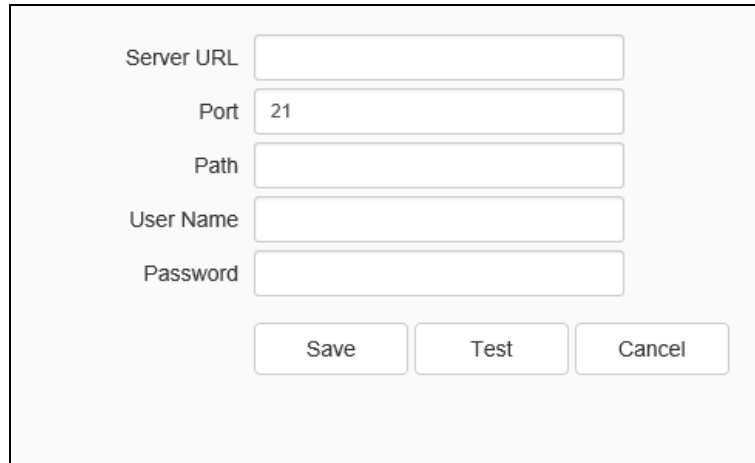

FTP setting interface

- Set the [Server URL], [Port], [Path], [User Name] and [Password].
- Click [Save], to set the FTP server information.
- Click [Cancel], to restore the last saved parameter.
- Click [Test], to Test whether the settings are correct and effective.

## 5.14 System

### 5.14.1 System

#### System - >Allocation of Resources

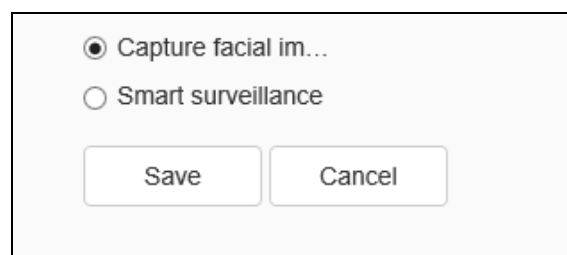

Fig.5.15.1.1 Allocation of resources interface

The user can modify the method of allocating resource, as Capture facial images or Smart surveillance.

- [Capture facial images]: When the algorithm finds a person's face in the video, it captures the image and saves it to the preset location.



- [Smart surveillance]: Common monitoring mode includes intelligent algorithms such as behavior analysis, crowd gathering, video diagnosis, audio detection etc.

## System - > Time

The screenshot shows a web-based configuration interface for time settings. It features a live video feed on the left and a control panel on the right. The control panel includes a 'Region' dropdown menu, radio buttons for 'Synchronization time' (Manual and NTP), a 'Local Time' text input, and a 'Set' button. Below these are options for 'Daylight-Saving Time' (Enabled/Disabled), 'Start Time' (Month, Day, and Hour), 'Stop Time' (Month, Day, and Hour), and 'DST Bias' (Offset). 'Save' and 'Cancel' buttons are located at the bottom of the panel.

Fig.5.15.1.2 Time setting interface

- [Region]: Select the Region from the drop-down list.
- [Synchronization Time]: The synchronization equipment time is the same as the local time. Select [Manual] or [NTP].
  - If you select Manual, the [Local Time] will appear.
  - If you select NPT, you need to configure the [NPT Server], [Port] and [Time Interval].
- [Local Time]: Real time display of local time.
- [Synchronization Time]: The synchronization equipment time is the same as the local time.
- [Daylight-Saving Time]: Set whether daylight saving time is enabled. Set the time range and offset time for daylight saving time.
- [NTP server]: Enter the legal IP address of the server.
- [Port]: Enter the corresponding port number.
- [Time Interval]: Enter the interval of automatic time calibration.
- [Test]: Test NTP automatic timing.

- 
- Click [Save] to save the currently set parameters. Click [Cancel] to restore the last saved parameter.

### System - > Serial Port

The screenshot shows a configuration window titled "Serial Port Set" and "Protocol Set". The "Serial Port Set" section includes dropdown menus for Port Name (COM2), Baud Rate (9600), Parity Bit (None), Byte Size, Stop Bit, and Work Mode (Protocol Mode). The "Protocol Set" section includes dropdown menus for Port Name (COM2), Protocol (DOME\_PELCO\_P), and a spinner for Address (1). At the bottom are "Save" and "Cancel" buttons.

Fig.5.15.1.3 Serial port setting interface

- Serial Port settings are divided into [Serial Port Set] and [Protocol Set].
- [Serial Port Set] you need to select [serial port number], [baud rate], [parity bit], [byte size], [stop bit] and [working mode].
- For [Protocol Set], you need to select the [protocol] and [address].

**Note:** When user set the peripherals, and [Save] all the setting, user can set [Temperature and humidity alarm] in [Event Management].

---

## 5.14.2 Users

### Users->users

No.	User Name	Authority	Edit	Delete	
1	Admin	Admin	<a href="#">Edit</a>		
<div style="text-align: right;"><input type="button" value="Add"/></div>					

Fig.5.15.2.1 Users

**Add**✕

User Name

Password

Password Strength  Poor  Mid  Strong

Please generate 6-15 digits password with two or more combinations of numbers, lowercase, capital letter and special character.

Password Confirm

Authority

Fig.5.15.2.2 Add User

The image shows a modal dialog box titled "Edit" with a close button (X) in the top right corner. The dialog contains the following elements:

- User Name:** A text input field containing "Admin".
- Old Password:** An empty text input field.
- Password:** An empty text input field.
- Password Strength:** Three buttons labeled "Poor", "Mid", and "Strong".
- Instructions:** A text block stating: "Please generate 6-15 digits password with two or more combinations of numbers, lowercase, capital letter and special character."
- Password Confirm:** An empty text input field.
- Authority:** A dropdown menu showing "Admin" with a downward arrow.
- Email:** An empty text input field.
- Optional (For Password Reset):** A text label below the Email field.
- Buttons:** "Save" and "Back" buttons located at the bottom right of the dialog.

Fig.5.15.2.3 Modity password

#### [Add User]

To add a new user, enter the user name, password, confirm password and set the permissions (authority). The user name and password can only be entered in English letters and Numbers. Click [Save] button.

**Note:** Only the administrator can add and modify users.

#### [Modify password]

In the user list, click [edit] and then pop up appears to change the password. Enter the new password and confirm the password confirm and click the [Save] button.

#### [Remove User]

In the user list, click the [Remove] button to pop up appears, click [Confirm].

## Users->Connection

Channel No.	Network Mode	Client IP	User Name	
Channel No.1 1st Stream	TCP	192.168.15.216	Admin	
Channel No.1 1st Stream	TCP	192.168.15.189	Admin	

Fig.5.15.2.3 Connection interface

Displays a detailed list of connects/logins to the device, including channel type, network mode, client IP, and user name. Click [Refresh] to update the list.

---

## 5.14.3 Maintenance

### Maintenance->Maintenance

The screenshot displays a web-based maintenance interface with three main sections:

- Device Control:** Contains five buttons: Basic Reset, Factory Reset, Reboot, Lens Reset, and Close Telnet.
- Configuration In/Out:** Features a file upload field labeled "Files (\*.box)", followed by "Browse", "Import", and "Export" buttons. A red note below reads: "Note: User need to manually input new IP to login again when IP address changed."
- Auto Maintenance:** Includes a "Restart Time" dropdown menu currently set to "Never" and a "Save" button.

Fig.5.15.3.1 Maintenance interface

#### [Device Control]

Allows you to perform [Basic Reset], [Factory Reset], [Reboot], [Lens Reset], [Open Telnet] and other operations.

#### [Configuration In/Out]

Allows you to import or export data. [Import ]/ [Export] is used for equipment maintenance, mainly divided into three categories:

- (1) [Event Server] options include alarm time period and linkage item setting information, excluding intelligent analysis.
- (2) [Smart Analytics ]options include settings related to intelligent analysis, including rules, time periods, etc.
- (3) [System Setting] options include all setting information except the above

---

alarm, intelligent analysis, logo, storage strategy and local setting, including video parameters, HD parameters, character superposition, video recording strategy, network setting and other information.

[Auto Maintenance]

Set the automatic reboot time of the dome camera to conduct automatic maintenance.

### Maintenance - > Upgrade

The screenshot displays a web interface for upgrading a device. It is divided into two main sections: 'Version Information' and 'Firmware Upgrade'. The 'Version Information' section lists various system details: Factory ID (ID0000270090081080960248), MAC (00:1b:09:08:6c:60), Hardware Version (2026), Kernel Version (NVSS\_V22.0.3.20201216), Web Version (6.1.20.615), CGI Version (CGI\_V3.0.0.20201214), ONVIF Version (ONVIF\_V3.2.0.20200610), P2P Version (P2P\_V3.2.0.20200610), RTMP Version (RTMP\_V3.2.0.20200610), RTMPCLIENT Version (RTMPCLIENT\_V3.2.0.20200610), RTSP Version (RTSP\_V3.2.0.20200610), and APP Version (APP\_V3.2.0.20200610). The 'Firmware Upgrade' section features a file selection field labeled 'Upgrade File (\*.box, \*.bin)', a 'Browse' button, and an 'Upgrade' button.

Fig.5.15.3.2 Upgrade interface

#### Upgrade - Version Information

[Version Information]: It includes equipment information such as [Factory ID], [MAC], [Hardware Version],[ Kernel Version] and [Web Version].

#### Upgrade - Firmware Upgrade

[Firmware Upgrade]: The user can select a local legal . Box or . Bin file to upgrade the device remotely. The upgrade operation of the kernel program

---

shall be conducted under the guidance of the company's technical personnel.

[Browse]: Find the upgrade file in the pop-up window.

[Upgrade]: Upgrade to the latest version through the network.

#### 5.14.4 Local PC Settings

**Local PC Setting**

**Attention: Local routes are only valid in IE browser.**

Record Videos	C:\Users\Administrator\NetVideoBrowser\RecordFile	Browse
Live Snapshots	C:\Users\Administrator\NetVideoBrowser\CapturePic	Browse
Playback Snapshots	C:\Users\Administrator\NetVideoBrowser\PlaybackP	Browse
Video Clips	C:\Users\Administrator\NetVideoBrowser\PlaybackF	Browse
Downloaded Files	C:\Users\Administrator\NetVideoBrowser\Downloadf	Browse
VCA Snapshots	C:\Users\Administrator\NetVideoBrowser\AlarmInfo\	Browse

Protocol Type: TCP

Local Capture Format: JPG

Enable GPU acceleration will take effect after reconnect the video.

Save Cancel

Fig.5.15.4Local PC Settings

Set the storage path for the following: [Record Video / Live Snapshots / Playback Snapshots / Video Clips / Downloaded Files / VCA Snapshots].

[Protocol Type]: User can choose the network connection protocol for the camera. When [Protocol Type] is [UDP], only one connection is supported.

In the drop-down list of [Local Capture Format], select the picture format of the local snapshot. Such as [JPG] or [BMP]. If send pic to FTP or Email, please select JPG.



---

[Enable GPU Acceleration]: Select the check box. After Video re-connects this will take effect.

**Note:** If the video preview is bad or the system crashes, you need to disable the GPU acceleration, because the PC hardware driver does not match.

## 6. Simple Troubleshooting

Fault Description	Possible reason	Troubleshooting method
No action ,image or self-checking when powered on	Power supply is damaged or insufficient	Change the power supply
	Wrong power-line connection	Amend, pay attention to the positive and negative side of DC power supply
	Wiring problem	troubleshoot the circuit and measure the terminal voltage of the dome camera
Self-checking normal	Wiring problem, damaged network cable or switch	PC connects to the dome camera directly to determine the problem segment
	The equipment is not in the same network segment as PC	Troubleshoot the line, modify the IP address to ensure that the IP does not conflict with each other
Cannot log in	User name or password error	check the current login user name and password of the dome camera
	Port number error	Check the port number of current dome camera
	Set up blacklist and whitelist	Hard reset
	Login account exceeds the limit	Disconnect other users
Normal login, unable to connect video	User-end connection exceeds equipment limit	excessive proxy of front-end video
	Camera abnormal	Check daily record of the equipment
	Parameter configuration error	Dome camera restores default parameters
Figure patchy	IP conflict, MAC conflict, broadcast storm	Troubleshoot circuit and network settings, capture packet, troubleshoot with direct connection
	circuit problem, network line virtual connection	troubleshoot circuit
Video break or jam or delay	PC insufficient performance	Check CPU usage rate, reduce bitstream and resolution
	Low frame rate setting, video breaking	Adjust the frame rate to more than 20 frames
	Lack of bandwidth	Substitute for Gigabit switch

	Insufficient performance of back-end decoding equipment	Substitute for high-performance NVR, decoder and other decoding equipment.
Cannot control the dome camera	Serial port setting error	Front-end dome camera serial port shall be COM2
	Baud rate, protocol or address error	Adjust control parameters of control end
Automatic restart the dome camera repeatedly	Insufficient power supply and unstable voltage	Measure the voltage of the dome camera terminal to ensure the power supply voltage stable
	PPPOE dialing failed	Dial parameters are set correctly, modify parameters
	The camera has no image. The dome camera is restarted	Camera damaged, replace camera
	Parameter setting abnormal	Restore default parameters
Cannot recognize TF card	Plug and unplug the TF card under power lost condition	Reinsert after power lost
		Reformat
	Card loosening	Reseat the TF card
Audio fault	Confirm that the driver and wiring of the corresponding sound card of the host are correct, and play music to test	Install audio driver
	Make sure that "audio and video streaming" is selected, not "video streaming"	Set as "audio and video" in audio and video parameters
	Wiring are correct	Re-wiring
	Adjust the audio input volume through IE, maybe it is too low	Re-set the volume

---

## **7. After-sales Services**

For the high-definition network series camera produced in our company, we promise one-year warranty. During the product warranty period, the company provides free maintenance services, but in case of the following circumstances, the material cost and labor cost shall be charged as appropriate:

1. The camera is damaged due to the operation not in accordance with the user manual;
2. Lightning, fire and irresistible natural disasters;
3. Damage caused by matching problems due to poor product design of other manufacturers;
4. Due to our continuous adoption of new technology, product parameters are subject to change without notice.

---

## 8. Appendix I Lightning Protection and Surge Protection

Lightning and surge protection shall be considered for outdoor cameras. On the premise of ensuring electrical safety, the following lightning protection measures can be taken:

1. The signal transmission line must be kept at least 50 meters away from the high-voltage equipment or high-voltage cable;
2. Outdoor wiring shall be routed under the eaves as much as possible;
3. For the open area, the sealed steel pipe must be buried for wiring, and the steel pipe shall be grounded at one point, and the overhead wiring is absolutely prohibited;
4. In strong thunderstorm area or high induced voltage area (such as high-voltage substation), additional high-power lightning protection equipment and lightning rod must be installed;
5. The lightning protection and grounding design of outdoor devices and lines must be considered in combination with the lightning protection requirements of buildings, and meet the requirements of relevant national standards and industry standards;
6. The system must be equipotential grounded. The grounding device must meet the double requirements of system anti-interference and electrical safety, and shall not be short circuited or mixed connected with the zero line of the strong current network. When the system is grounded separately, the grounding impedance shall not be greater than  $4 \Omega$ , and the cross-sectional area of the grounding conductor shall not be less than  $25\text{mm}^2$ .

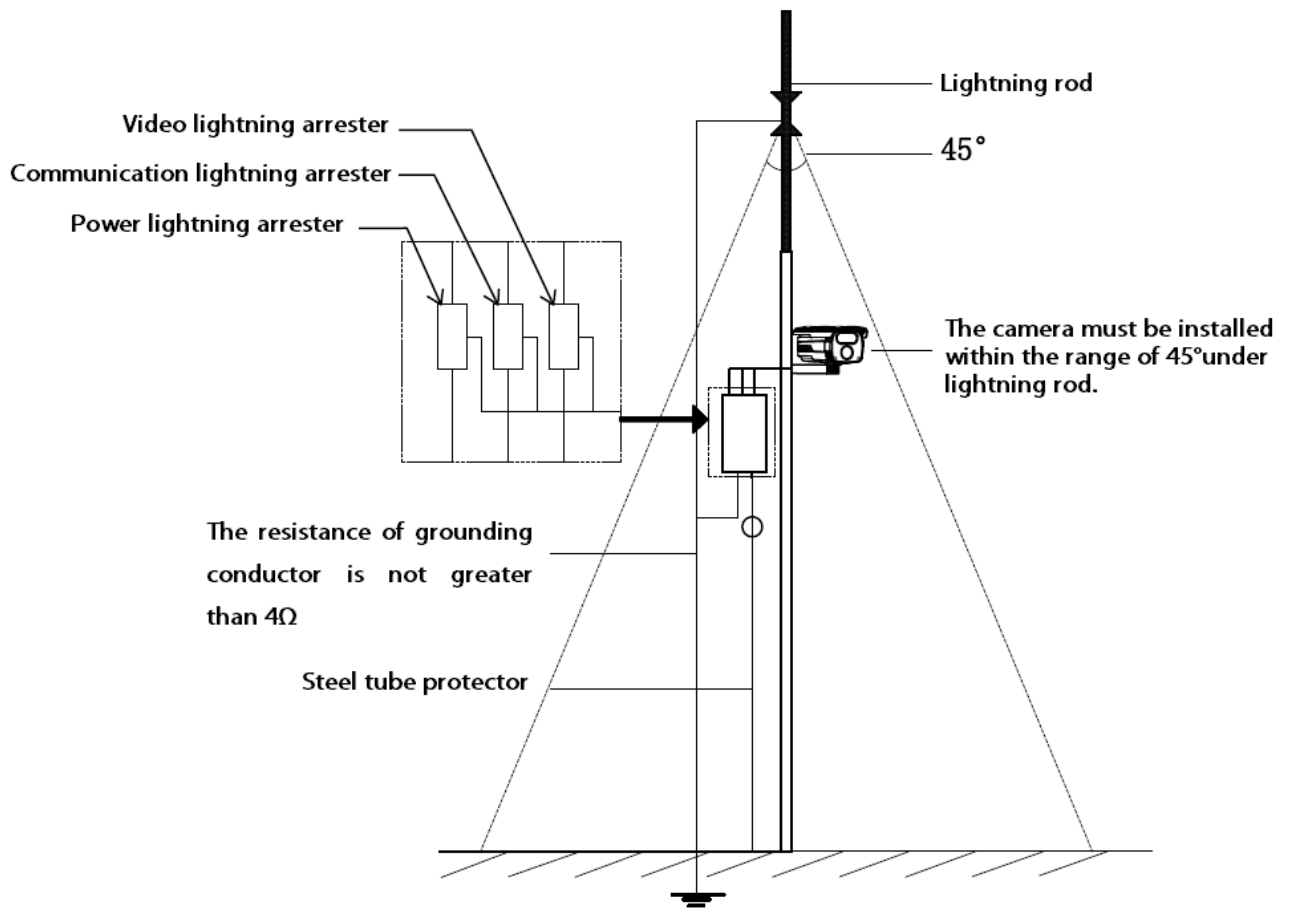

---

# Disposal of Products/Components after End-Of-Life

**Main components of Matrix products are given below:**

- **Soldered Boards:** At the end-of-life of the product, the soldered boards must be disposed through e-waste recyclers. If there is any legal obligation for disposal, you must check with the local authorities to locate approved e-waste recyclers in your area. It is recommended not to dispose-off soldered boards along with other waste or municipal solid waste.
- **Batteries:** At the end-of-life of the product, batteries must be disposed through battery recyclers. If there is any legal obligation for disposal, you may check with local authorities to locate approved batteries recyclers in your area. It is recommended not to dispose off batteries along with other waste or municipal solid waste.
- **Metal Components:** At the end-of-life of the product, Metal Components like Aluminum or MS enclosures and copper cables may be retained for some other suitable use or it may be given away as scrap to metal industries.
- **Plastic Components:** At the end-of-life of the product, plastic components must be disposed through plastic recyclers. If there is any legal obligation for disposal, you may check with local authorities to locate approved plastic recyclers in your area.

After end-of-life of the Matrix products, if you are unable to dispose-off the products or unable to locate e-waste recyclers, you may return the products to Matrix Return Material Authorization (RMA) department.

Make sure these are returned with:

- proper documentation and RMA number
- proper packing
- pre-payment of the freight and logistic costs.

Such products will be disposed-off by Matrix.

**"SAVE ENVIRONMENT SAVE EARTH"**

---

# **E-Waste Management and Handling Rules**

E-waste is a popular, informal name for electronic products nearing the end of their useful life. E-wastes are considered dangerous, as certain components of some electronic products contain materials that are hazardous, depending on their condition and density. The hazardous content of these materials pose a threat to human health and environment. Discarded electronics products such as circuit boards, batteries, wires and other electronic accessories if improperly disposed can leach lead and other substances into soil and groundwater. Many of electronic products can be reused, refurbished or recycled in an environmentally sound manner so that they are less harmful to the ecosystem.

## **Benefits of E-waste Recycling leach**

### **Electronics Recycling Conserves Natural Resources**

There are many materials that can be recovered from old electronic products. These materials can be used to make new products, thus reducing the need for the new raw materials. For instance, various metals can be recovered from circuit boards and other electronics can be recycled.

### **Electronics Recycling Supports the Community**

Donating your old electronics plays an important role in the provision of refurbished products which can be of great help to certain industries, small organizations and non-profitable organizations. It also helps individuals gain access to technology that they could not have otherwise afforded.

### **Electronics Recycling Creates Employment Locally**

Considering that around 90 percent of electronic equipment is recyclable, electronics recycling can play a significant role in creating employment. This is because new firms dealing with electronics recycling will form and existing firms will look to employ more people to recover recyclable materials. This can be triggered by the increase in the demand for electronics recycling.

### **Electronics Recycling Helps Protect Public Health and the Environment**

Many electronics have toxic or hazardous materials such as mercury and lead, which can be harmful to the environment if disposed in trashcans. Reusing and recycling electronics safely helps in keeping the hazardous materials from



---

harming humans or the environment. For example, certain electronic components and batteries are hazardous since they have lead in them. Printed circuit boards contain harmful materials such as cadmium, lead, mercury and chromium.

Instead of keeping old electronics or dumping them in landfills, recycling or reusing them is an appropriate option that should be supported by individuals and organizations. Considering the benefits of electronics recycling, it is very important that people in various parts around the world embrace this concept.

### **Creates Jobs**

E-waste recycling creates new jobs for professional recyclers and creates a second market for the recycled materials.

### **Do's & Don'ts**

Do's:

- Always look for information on the catalogue with your product for end-of-life equipment handling.
- Ensure that only Authorized Recyclers/Dismantler handle your electronic products.
- Always call at our toll-free No's to Dispose products that have reached end-of life.
- Always drop your used electronic products, batteries or any accessories, when they reach the end of their life at your nearest Authorized E-Waste Collection Points.
- Always disconnect the battery from product and ensure any glass surface is protected against breakage.

Don'ts:

- Do not dismantle your electronic Products on your own.
- Do not throw electronics in bins having "Do not Dispose" sign.
- Do not give e-waste to informal and unorganized sectors like Local Scrap Dealer/ Rag Pickers.
- Do not dispose your product in garbage bins along with municipal waste that ultimately reaches landfills.

### **E-Waste Management Plan**

**M/s. MATRIX COMSEC PVT LTD** has partnered with **E-Waste Recyclers India (EWRI)** to comply with the new India E-Waste management and

---

handling rules in providing drop-of centers and environmentally sound management of end of life electronics.

EWRI has obtained authorizations from the appropriate governmental agency for their processing facilities. EWRI will receive and recycle customer returned equipment, including all the e-waste. Customers can drop their e-waste in the drop-box provided at various collection centers of EWRI.

A list of collection centers along with the address is mentioned below.

The customers can also call on the following toll free number (1800-102-5679) from Monday to Friday between 10:00 AM to 5:30 PM to get details about the collection centers.

### **Collection Centers:**

<b>State/ City</b>	<b>Location</b>	<b>Logistic</b>	<b>Address</b>	<b>Toll-Free Number</b>
Delhi	Rangpuri	Professional Logistics	Rangpuri, Milakpur Kohi Rangpuri, Rangpuri, New Delhi - 110037	1800-102-5679
Gurugram	Gurugram	Professional Logistics	295, LIG Colony, Sector 31, Gurugram, Haryana - 122022	1800-102-5679
Jharkhand	Dhanbad	Professional Logistics	Sardar Patel Nagar, Dhanbad, Jharkhand - 826004	1800-102-5679
Noida	Salarpur Khadar	Professional Logistics	2, Gejha Rd, Goyal Colony, Salarpur Khadar, Sector 102, Noida, Uttar Pradesh - 201304	1800-102-5679
Mumbai	Vashi	Professional Logistics	Plot-92,gala no 01,Sector 19C Vashi Navi Mumbai - 400705	1800-102-5679
Pune	Vallabh Nagar	Professional Logistics	No.3/20,Near Ashok Sah Bank, Vallabh Nagar, S.T.Stand Road, Pimpri, Pune - 302021	1800-102-5679
Odisha	Cuttack	Professional Logistics	Cuttack, Odisha	1800-102-5679
Hyderabad	Secunderabad	Professional Logistics	4,Block-3,4th Shatter at 179, MPR Estates Near Old Check Post Old Bowaenpally Secunderabad, Hyderabad - 500011	1800-102-5679

Bangalore	Yeshwanthpur	Professional Logistics	No.44 1st floor 2nd main D.D.U.T.T.L. Yeshwanthpur, Bangalore - 560022	1800-102-5679
Mangalore	Bhathery Road Bolor	Professional Logistics	Opp. Hindustan Lever Ltd, Sulthan, Bhathery Road Bolor, Mangalore (KA) - 575003	1800-102-5679
Jharkhand	Ranchi	Professional Logistics	Ranchi, Jharkhand	1800-102-5679
Chennai	Sennerkuppam	Professional Logistics	27,Sakthi Nagar Phase-II, Sennerkuppam, Near Bisleri Water Plant, Chennai - 600056	1800-102-5679
Rajasthan	Jaipur	Professional Logistics	A-81, 200 ft. By Pass, Heerapura, Jaipur, Rajasthan - 302021	1800-102-5679
Bokaro	Odisha	Professional Logistics	Cuttack, Odisha, India	1800-102-5679
Guwahati	Kundil	Professional Logistics	HN-34, Kundil Nagar Basistha Chariali, Near Parbhat Apartment, Guwahati - 781029	1800-102-5679
Lucknow	Kanpur Road	Professional Logistics	S-175,1st Floor Transport Nagar Near RTO Kanpur Road Lucknow - 226004	1800-102-5679
Madhya Pradesh	Indore	Professional Logistics	284 AS-3 Scheme No.-78,Vijay Nagar, Indore, Madhya Pradesh	1800-102-5679
Ahmedabad	Pushp Penament	Professional Logistics	Shop No D-18, Pushp Penament, Behind Mony Hotel, Isanpur, Ahmedabad	1800-102-5679
Patna	Malyanil buddha	Professional Logistics	Dr. A.K Pandey (IPS) Malyanil buddha Colony, Patna (Bihar) - 800001	1800-102-5679
Andhra Pradesh	Vishakapatna m	Professional Logistics	Shop No.8, New Gajuwaka, Opp. High School Road, Vishakapatnam, Andhra Pradesh - 530026	1800-102-5679
Chandigarh	Pharbhat Road	Professional Logistics	Shop no:-19, Pharbhat Road, Opp:- Tennis Academy, Zirakpur, Chandigarh, Punjab	1800-102-5679

---

Kolkata	B.T. ROAD DUNLOP	Professional Logistics	156A/73, Northern Park, B.T. Road Dunlop, Kolkata -700108	1800-102-5679
Odisha	Bhubaneswar	Professional Logistics	Acharya Vihar - jaydev Vihar Rd, Bhubaneswar, Odisha	1800-102-5679
West Bengal	Asansol	Professional Logistics	Shop No-4 Asansol Station Bus Stand Road, Munshi Bazar, Asansol, West Bengal - 713301	1800-102-5679



## **MATRIX COMSEC**

### **Head Office:**

394-GIDC, Makarpura,  
Vadodara – 390010, India.

Phone:(+91)18002587747

E-mail:

[Support@MatrixComsec.com](mailto:Support@MatrixComsec.com)

[www.matrixaccesscontrol.com](http://www.matrixaccesscontrol.com)

*Release: 27 August, 2021.*